

Features

- One-piece wall-hung toilet
- Compact elongated bowl offers added comfort while occupying the same space as a round-front bowl
- Mounting hardware is completely concealed, giving a sleek, seamless look that is easy to clean
- Includes wall-hung bowl with Reveal® Quiet-Close™ seat
- Requires in-wall tank and carrier system, and flush actuator plate (sold separately)

Installation

- This product is not designed or intended for bariatric use

Required Products/Accessories

[K-6284](#) 2" x 6" In-wall tank and carrier system

or

[K-18829](#) 2" x 4" In-wall tank and carrier system

[K-5413](#) Flush Actuator Plate

or

[K-18829](#) 2" x 4" In-wall tank and carrier system

[K-4177](#) Flush Actuator Plate

or

[K-18829](#) 2" x 4" In-wall tank and carrier system

[K-8857](#) Flush Actuator Plate

or

[K-18829](#) 2" x 4" In-wall tank and carrier system

[K-75890](#) Flush Actuator Plate

or

[K-18829](#) 2" x 4" In-wall tank and carrier system

Recommended Products/Accessories

K-23726 Drain treatment

Included Components

K-4008 Reveal® Quiet-Close™ elongated toilet seat



ADA

CSA B651

OBC

Codes/Standards

ASME A112.19.2/CSA B45.1

ASME A112.19.14

DOE - Energy Policy Act 1992

EPA WaterSense®

California Energy Commission (CEC)

ADA

ICC/ANSI A117.1

CSA B651

OBC

NOM Standards

NOM 009-CNA

IAPMO Certification

KOHLER® Toilets and Seats Limited Warranty

See website for detailed warranty information.

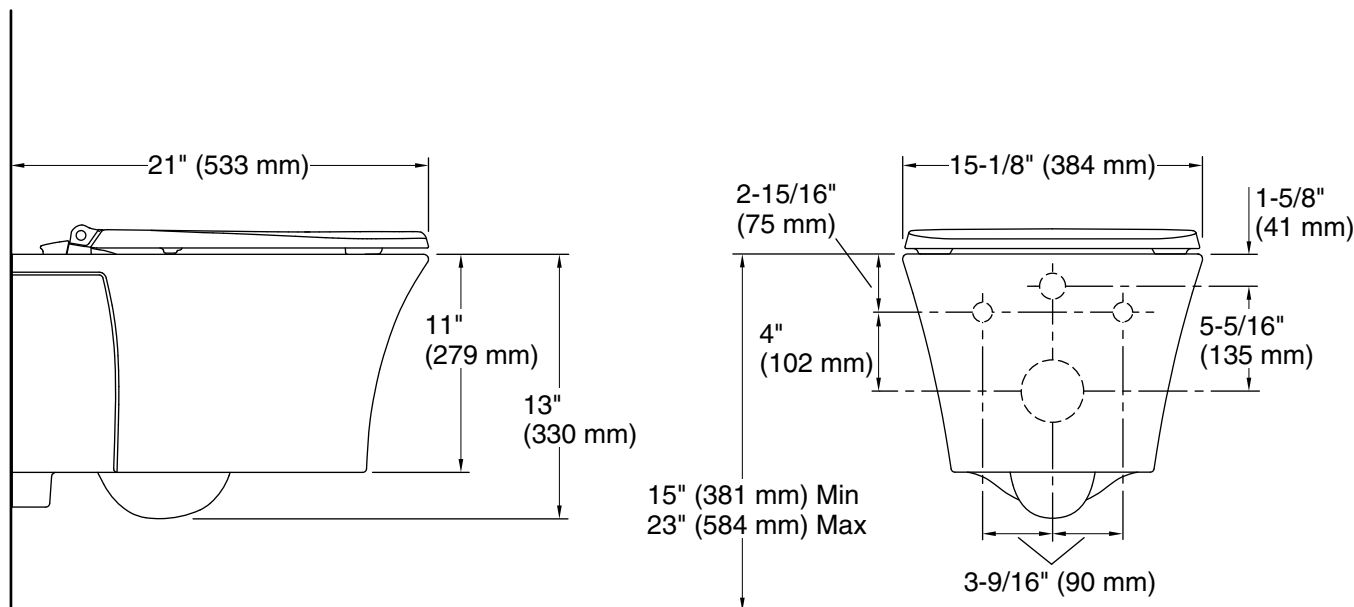

Technical Information

All product dimensions are nominal.

Toilet type:	Wall-mount
Waste Outlet:	Wall
Bowl shape:	Elongated
Flush type:	Class Five
Trap passageway:	3" (76 mm)
Water surface size:	4-1/2" x 5-1/2" (114 mm x 140 mm)
Rim to water surface:	8-3/16" (208 mm)
Seat-mounting holes:	5-1/2" (140 mm)

Notes

Install this product according to the installation instructions.

Toilet height is dependent on carrier settings. ADA, OBC, CSA B651 compliant when installed to the specific requirements of these regulations.

Plumbing codes may require elongated toilets and elongated, open-front seats in public bathrooms.

Accessibility standards may require controls to be located on the open side of the toilet.