

FEATURES

- 12" rough-in
- Vitreous china
- 9-1/8" x 8-5/8" water area
- Round front bowl
- Includes Lustra™ seat
- One-piece
- Less supply
- 1.6 gpf
- Includes polished chrome trip lever

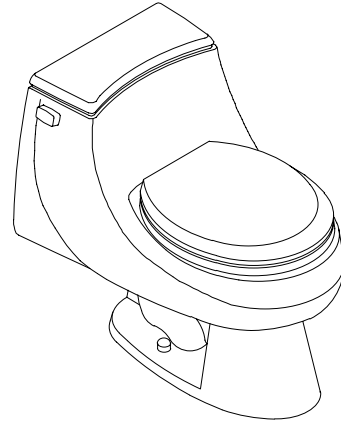

CODES/STANDARDS APPLICABLE

Specified model meets or exceeds the following:

- ASME/ANSI A112.19.2M
- ASME/ANSI A112.19.6M
- Energy Policy Act of 1992 (EPACT)
- IAPMO/UPC
- Canadian Standards Association (CSA)
- States of Massachusetts, New York, & Texas
- Cities of Los Angeles, CA

COLORS/FINISHES

- 0 White
- Other Refer to Fixtures Price Book for additional colors

Accessories:

- CP Polished Chrome
- PB Polished Brass
- Other Refer to Price Book for additional colors

SPECIFIED MODEL:

Model	Description	Colors/Finishes		
K-3434	Round front bowl toilet	<input type="checkbox"/> 0 White	<input type="checkbox"/> Other_____	
Recommended Accessories				
K-7637	Angle supply with stop	<input type="checkbox"/> CP	<input type="checkbox"/> PB	<input type="checkbox"/> Other_____
Optional Accessories				
K-9432	Trip lever (non-CP)	<input type="checkbox"/> PB	<input type="checkbox"/> Other_____	

PRODUCT SPECIFICATION:

The round front one-piece toilet shall be 12" rough-in. Toilet shall be made of vitreous china. Toilet shall have 9-1/8" x 8-5/8" water area. Toilet shall include Lustra™ seat. Toilet shall be less supply. Toilet shall be 1.6 gpf. Toilet shall include polished chrome trip lever. Toilet shall be Kohler Model K-3434-_____.

PRODUCT INFORMATION

Fixture:	
Configuration	1-piece, round front
Gallons per flush	1.6 gallons
Passageway	2"
Water area	9-1/8" x 8-5/8"
Water depth from rim	6-7/8"
Seat post hole centers	5-1/2"
Included Components:	
Seat	K-4662
Tank cover	83693
Trip lever	K-9432
Bolt cap accessory pack	52048
Tank accessory pack	52265

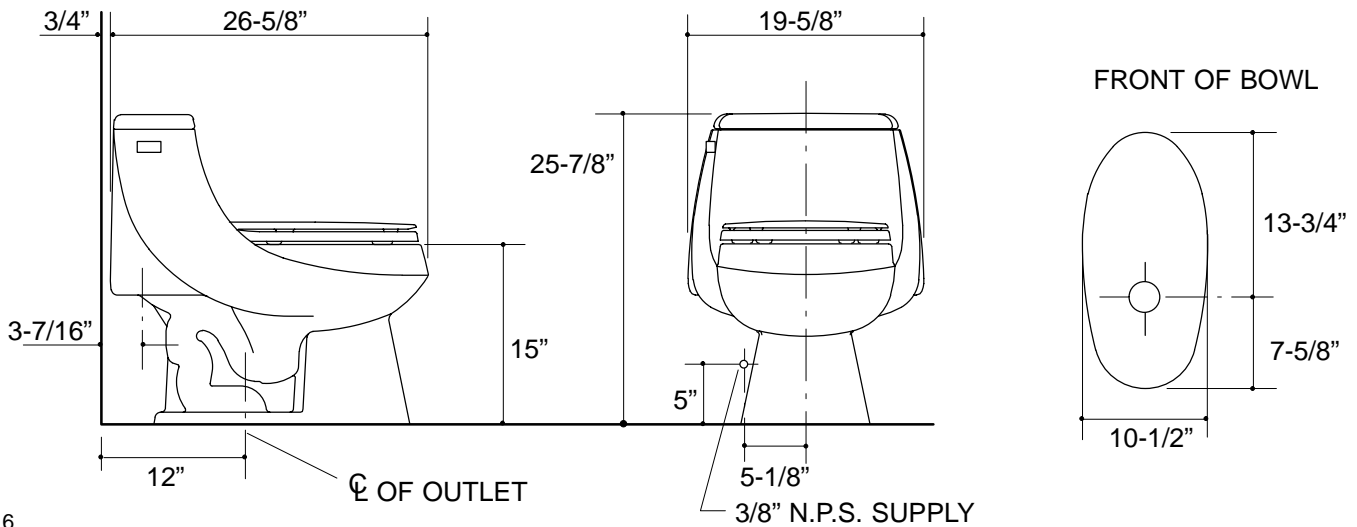

116

PRODUCT DIAGRAM