

Operation

Automatic Transfer Switches

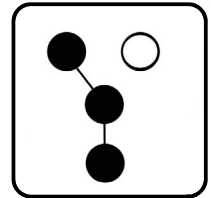

Controls: Decision-Maker® MPAC 1200

Transfer Switch Models:
KCS/KCP/KCC
KSS/KSP
KSSB

Table of Contents

Safety Precautions and Instructions	7
Introduction	9
List of Related Materials	9
Service Assistance	10
Section 1 Operation	11
1.1 Introduction	11
1.2 Source Names	11
1.3 User Interface Panel	11
1.3.1 Display	12
1.3.2 Display Contrast	12
1.3.3 Pushbuttons	12
1.3.4 LED Indicators	13
1.3.5 Lamp Test	13
1.3.6 Examples	13
1.4 Main Menu	15
1.5 Passwords	16
1.5.1 Changing Passwords	16
1.5.2 Test Password Reset and Disable	16
1.6 Normal Operation Menus	17
1.7 System Test	18
1.7.1 Unloaded System Test	19
1.7.2 Loaded System Test	19
1.7.3 Closed-Transition Loaded Test	19
1.7.4 Auto-Loaded System Test	20
1.7.5 Sync Check (closed-transition)	20
1.8 Automatic Operation Test	20
1.9 Exercise	23
1.9.1 Unloaded Exercise	23
1.9.2 Load Bank Control	23
1.9.3 Loaded Exercise	23
1.10 Warnings and Faults	24
1.10.1 Fault Reset	25
1.11 Accessory Module Faults	25
1.11.1 Module Status Change	25
1.11.2 Module Status Conflict	26
1.12 Reset Data	27
1.12.1 Reset Maintenance Records	27
1.12.2 Reset Event History	27
1.12.3 Reset Default Parameters	28
1.12.4 Reset and Disable Test Password	28
Section 2 Sequence of Operation	29
2.1 Controller Power-up/Reset	29
2.2 Sequence of Operation, Standard Transition Models	30
2.2.1 Preferred Source Loss and Return, Standard Transition	30
2.2.2 Exerciser Operation, Standard Transition	30
2.2.3 Test Sequence, Standard Transition	31
2.3 Sequence of Operation, Programmed-Transition	32
2.3.1 Preferred Source Loss and Return, Programmed Transition	32
2.3.2 Exerciser Operation, Programmed Transition	32
2.3.3 Test Sequence, Programmed Transition	33
2.4 Sequence of Operation, Closed-Transition Models	34
2.4.1 Preferred Source Loss and Return, Closed Transition	34
2.4.2 Failure to Synchronize (Programmed-Transition Override)	34

Table of Contents, continued

2.4.3	Exerciser Operation, Closed Transition	35
2.4.4	Test Sequence, Closed Transition	35
2.4.5	Extended Transfer Time Relay	36
Section 3	View Screens	37
3.1	Introduction	37
3.2	Main Screen	37
3.3	View Screens	37
3.4	View Event History	38
3.5	View Maintenance Records	38
3.6	View Exerciser Setup	39
3.7	View System Setup	39
3.8	View Source Setup	40
3.9	View Time Delays, Source 1	42
3.10	View Time Delays, Source 2	43
3.11	View Inputs/Outputs	44
3.12	View Common Alarms	44
3.13	View Communications Setup	45
3.14	View Control Parameters	45
Section 4	Setup	47
4.1	Introduction	47
4.2	Setup Menus	47
4.3	Time/Date	48
4.4	Exerciser	49
4.5	Time Delays	50
4.5.1	Time Delays	50
4.5.2	Load Control Time Delays	50
4.5.3	Set S1 Time Delays	51
4.5.4	Set S2 Time Delays	52
4.5.5	Time-Based Load Control	53
4.6	Set Sources	55
4.6.1	Phase Rotation	55
4.6.2	In-Phase Monitor	55
4.6.3	Preferred Source Selection	55
4.6.4	System Voltage and Frequency	57
4.6.5	Voltage and Frequency Pickup and Dropout Settings	57
4.6.6	Set Sources	58
4.7	Inputs and Outputs	61
4.7.1	Controller Inputs and Outputs	61
4.7.2	Input/Output Modules	61
4.7.3	Input Functions	62
4.7.4	Output Functions	63
4.7.5	User-Defined I/O Descriptions	64
4.8	Common Alarms	65
4.8.1	Common Alarm Output	65
4.8.2	Audible Alarm	65
4.8.3	Chicago Alarm	65
4.9	Set System	66
4.9.1	Default Settings	66
4.9.2	Source Type/Source Type	66
4.9.3	Transition Type	66
4.9.4	Rated Current	66
4.9.5	Transfer Commit	66
4.9.6	Remote Test Loading	67
4.9.7	Peak Shave TD Bypass	67

Table of Contents, continued

- 4.10 Communications 68
- 4.11 Set Passwords 68
- 4.12 Calibration 69
- 4.13 Setting the Current to Zero 70
- 4.14 Reset Data 70
- Section 5 Communications 71**
 - 5.1 Introduction 71
 - 5.2 Connections 71
 - 5.2.1 USB Port SiteTech Connection 71
 - 5.2.2 Modbus Connection 72
 - 5.2.3 Ethernet Connection (Optional) 72
 - 5.3 Communications Setup 73
 - 5.3.1 Modbus Serial Communication Setup 73
 - 5.3.2 Network Communication Setup 73
 - 5.3.3 Setup Using the Controller Keypad 73
 - 5.3.4 Setup Using SiteTech 73
 - 5.4 Parameter Files 77
 - 5.5 Controller Firmware Updates 77
- Section 6 Scheduled Maintenance 79**
 - 6.1 Introduction 79
 - 6.2 Testing 80
 - 6.2.1 Weekly Generator Set Exercise 80
 - 6.2.2 Monthly Automatic Control System Test 80
 - 6.3 Inspection and Service 80
 - 6.3.1 External Inspection 80
 - 6.3.2 Internal Inspection 81
 - 6.3.3 SPD Inspection 81
 - 6.3.4 Other Inspections and Service 81
 - 6.4 Service Schedule 82
- Section 7 Accessories 83**
 - 7.1 Introduction 83
 - 7.2 Accessory Modules 83
 - 7.2.1 Input/Output (I/O) Modules 84
 - 7.2.2 External Battery Supply Module (EBSM) 85
 - 7.2.3 Alarm Module 86
 - 7.3 Controller Disconnect Switch 88
 - 7.4 Current Sensing 89
 - 7.5 Digital Meter 91
 - 7.6 Ethernet Communication Board 91
 - 7.7 Heater 92
 - 7.8 Line-to-Neutral Voltage Monitoring 93
 - 7.9 Load Shed (Forced Transfer to OFF) 93
 - 7.9.1 Description 93
 - 7.9.2 Customer Connection 93

Table of Contents, continued

7.10	Supervised Transfer Control Switch	95
7.10.1	Manual Transfer	95
7.10.2	Automatic Transfer Switches	95
7.10.3	Non-Automatic Transfer Switches	96
7.11	Surge Protection (SPD)	97
7.11.1	SPD Status Indicators	99
7.11.2	SPD Remote Status Indicator	99
7.11.3	SPD Replacement	99
7.12	User Interface Cover	100
Appendix A Abbreviations		101
Appendix B Screen Summaries		103

Safety Precautions and Instructions

IMPORTANT SAFETY INSTRUCTIONS. Electromechanical equipment, including generator sets, transfer switches, switchgear, and accessories, can cause bodily harm and pose life-threatening danger when improperly installed, operated, or maintained. To prevent accidents be aware of potential dangers and act safely. Read and follow all safety precautions and instructions. **SAVE THESE INSTRUCTIONS.**

This manual has several types of safety precautions and instructions: Danger, Warning, Caution, and Notice.

DANGER

DANGER indicates a hazardous situation which, if not avoided, will result in death or serious injury.

WARNING

WARNING indicates a hazardous situation which, if not avoided, could result in death or serious injury.

CAUTION



CAUTION indicates a hazardous situation which, if not avoided, could result in minor or moderate injury.

NOTICE

NOTICE is used to address practices not related to physical injury.

Safety decals affixed to the equipment in prominent places alert the operator or service technician to potential hazards and explain how to act safely. The decals are shown throughout this publication to improve operator recognition. Replace missing or damaged decals.



Accidental Starting



 WARNING

Accidental starting. Can cause severe injury or death. Disconnect the battery cables before working on the generator set. Remove the negative (-) lead first when disconnecting the battery. Reconnect the negative (-) lead last when reconnecting the battery.

Disabling the generator set. Accidental starting can cause severe injury or death. Before working on the generator set or equipment connected to the set, disable the generator set as follows: (1) Move the generator set master switch to the OFF position. (2) Disconnect the power to the battery charger. (3) Remove the battery cables, negative (-) lead first. Reconnect the negative (-) lead last when reconnecting the battery. Follow these precautions to prevent starting of the generator set by an automatic transfer switch, remote start/stop switch, or engine start command from a remote computer.

Disabling the generator set. Accidental starting can cause severe injury or death. Before working on the generator set or equipment connected to the set, disable the generator set as follows: (1) Press the generator set off/reset button to shut down the generator set. (2) Disconnect the power to the battery charger, if equipped. (3) Remove the battery cables, negative (-) lead first. Reconnect the negative (-) lead last when reconnecting the battery. Follow these precautions to prevent the starting of the generator set by the remote start/stop switch.

Hazardous Voltage/ Moving Parts

 DANGER

Hazardous voltage. Will cause severe injury or death. Disconnect all power sources before opening the enclosure.

 DANGER

Hazardous voltage. Will cause severe injury or death. Only authorized personnel should open the enclosure.

Grounding electrical equipment. Hazardous voltage will cause severe injury or death. Electrocutation is possible whenever electricity is present. Ensure you comply with all applicable codes and standards. Electrically ground the generator set, transfer switch, and related equipment and electrical circuits. Turn off the main circuit breakers of all power sources before servicing the equipment. Never contact electrical leads or appliances when standing in water or on wet ground because these conditions increase the risk of electrocution.

Short circuits. Hazardous voltage/current will cause severe injury or death. Short circuits can cause bodily injury and/or equipment damage. Do not contact electrical connections with tools or jewelry while making adjustments or repairs. Remove all jewelry before servicing the equipment.

Servicing the transfer switch. Hazardous voltage will cause severe injury or death. Deenergize all power sources before servicing. Turn off the main circuit breakers of all transfer switch power sources and disable all generator sets as follows: (1) Move all generator set master controller switches to the OFF position. (2) Disconnect power to all battery chargers. (3) Disconnect all battery cables, negative (-) leads first. Reconnect negative (-) leads last when reconnecting the battery cables after servicing. Follow these precautions to prevent the starting of generator sets by an automatic transfer switch, remote start/stop switch, or engine start command from a remote computer. Before servicing any components inside the enclosure: (1) Remove all jewelry. (2) Stand on a dry, approved electrically insulated mat. (3) Test circuits with a voltmeter to verify that they are deenergized.



Making line or auxiliary connections. Hazardous voltage will cause severe injury or death. To prevent electrical shock deenergize the normal power source before making any line or auxiliary connections.

Servicing the transfer switch controls and accessories within the enclosure. Hazardous voltage will cause severe injury or death. Disconnect the transfer switch controls at the inline connector to deenergize the circuit boards and logic circuitry but allow the transfer switch to continue to supply power to the load. Disconnect all power sources to accessories that are mounted within the enclosure but are not wired through the controls and

deenergized by inline connector separation. Test circuits with a voltmeter to verify that they are deenergized before servicing.

Testing live electrical circuits. Hazardous voltage or current will cause severe injury or death. Have trained and qualified personnel take diagnostic measurements of live circuits. Use adequately rated test equipment with electrically insulated probes and follow the instructions of the test equipment manufacturer when performing voltage tests. Observe the following precautions when performing voltage tests: (1) Remove all jewelry. (2) Stand on a dry, approved electrically insulated mat. (3) Do not touch the enclosure or components inside the enclosure. (4) Be prepared for the system to operate automatically. *(600 volts and under)*

Heavy Equipment

 WARNING

<p>Unbalanced weight. Improper lifting can cause severe injury or death and equipment damage.</p> <p>Use adequate lifting capacity. Never leave the transfer switch standing upright unless it is securely bolted in place or stabilized.</p>

Notice

NOTICE

Improper operator handle usage. Use the manual operator handle on the transfer switch for maintenance purposes only. Return the transfer switch to the normal position. Remove the manual operator handle, if used, and store it in the place provided on the transfer switch when service is completed.

NOTICE

Electrostatic discharge damage. Electrostatic discharge (ESD) damages electronic circuit boards. Prevent electrostatic discharge damage by wearing an approved grounding wrist strap when handling electronic circuit boards or integrated circuits. An approved grounding wrist strap provides a high resistance (about 1 megohm), *not a direct short*, to ground.

This manual provides operation instructions for Kohler® Decision-Maker® MPAC 1200 automatic transfer switch controls and related accessories.

The Decision-Maker® MPAC 1200 controller is available for the transfer switch models shown below.

Model	Description
KCS	Standard-Transition Any Breaker ATS *
KCP	Programmed-Transition Any Breaker ATS *
KCC	Closed-Transition Any Breaker ATS †
KSS	Standard-Transition Specific Breaker ATS *
KSP	Programmed-Transition Specific Breaker ATS *
KSSB	Standard-Transition Specific Breaker ATS *
* Available with automatic or non-automatic controller	
† Available with automatic controller only	

Information in this publication represents data available at the time of print. Kohler Co. reserves the right to change this literature and the products represented without notice and without any obligation or liability whatsoever.

The equipment service requirements are very important to safe and efficient operation. Inspect parts often and

perform required service at the prescribed intervals. Obtain service from an authorized service distributor/dealer to keep equipment in top condition.

Read this manual and carefully follow all procedures and safety precautions to ensure proper equipment operation and to avoid bodily injury. Read and follow the Safety Precautions and Instructions section at the beginning of this manual. Keep this manual with the equipment for future reference.

List of Related Materials

A separate transfer switch installation manual provided with the unit contains instructions for transfer switch installation instructions, and manual operation procedures.

Literature Item	Part Number
Specification Sheet, MPAC 1200 Controller	G11-127
Installation Manual, Model KCS/KCP/KCC	TP-6833
Installation Manual, Model KSS/KSP	TP-6834
Installation Manual, Model KSSB	TP-7191
Operation Manual, Modbus Protocol	TP-6113

Service Assistance

For professional advice on generator set power requirements and conscientious service, please contact your nearest Kohler distributor or dealer.

- Visit the Kohler Co. website at KOHLERPower.com.
- Look at the labels and decals on your Kohler product or review the appropriate literature or documents included with the product.
- Call toll free in the US and Canada 1-800-544-2444.
- Outside the US and Canada, call the nearest regional office.

Headquarters Europe, Middle East, Africa (EMEA)

Kohler EMEA Headquarters
Netherlands B.V.
Kristallaan 1
4761 ZC Zevenbergen
The Netherlands
Phone: (31) 168 331630
Fax: (31) 168 331631

Asia Pacific

Kohler Asia Pacific Headquarters
Singapore, Republic of Singapore
Phone: (65) 6264-6422
Fax: (65) 6264-6455

China

North China Regional Office, Beijing
Phone: (86) 10 6518 7950
(86) 10 6518 7951
(86) 10 6518 7952
Fax: (86) 10 6518 7955

East China Regional Office, Shanghai
Phone: (86) 21 6288 0500
Fax: (86) 21 6288 0550

India, Bangladesh, Sri Lanka

India Regional Office
Bangalore, India
Phone: (91) 80 3366208
(91) 80 3366231
Fax: (91) 80 3315972

Japan, Korea

North Asia Regional Office
Tokyo, Japan
Phone: (813) 3440-4515
Fax: (813) 3440-2727

1.1 Introduction

This section contains operation instructions, including:

- User interface panel, with display, pushbuttons, and LED indicators
- Main menu
- System status, warnings, and faults
- Passwords
- Tests
- Warnings and Faults
- Reset Data

1.2 Source Names

Throughout this manual, the sources are referred to as follows. Source 1 (S1) is connected to the Normal side of the transfer switch and is also referred to as Source N. Source 2 (S2) is connected to the Emergency side of the transfer switch and is also called Source E. For the MPAC 1200 controller, Source 1 is the utility source, and

Source 2 is the standby generator set. The engine start contacts are associated with Source 2.

The Preferred Source is the source that will be used if both sources are available. Typically, this is the normal utility source 1. If the transfer switch is equipped with the optional alarm module, the Set Preferred Source menu allows the operator to select either source as the preferred source. Source 2 (connected to the emergency side of the contactor) can be set as the preferred source using this menu. See Section 4.6.3 for more information about preferred source selection.

Other applications may use different configurations, such as the gen-gen configuration which uses two generator set sources and no utility.

1.3 User Interface Panel

The user interface panel is located on the transfer switch door. Figure 1-1 shows the user interface pushbuttons and LED indicators.

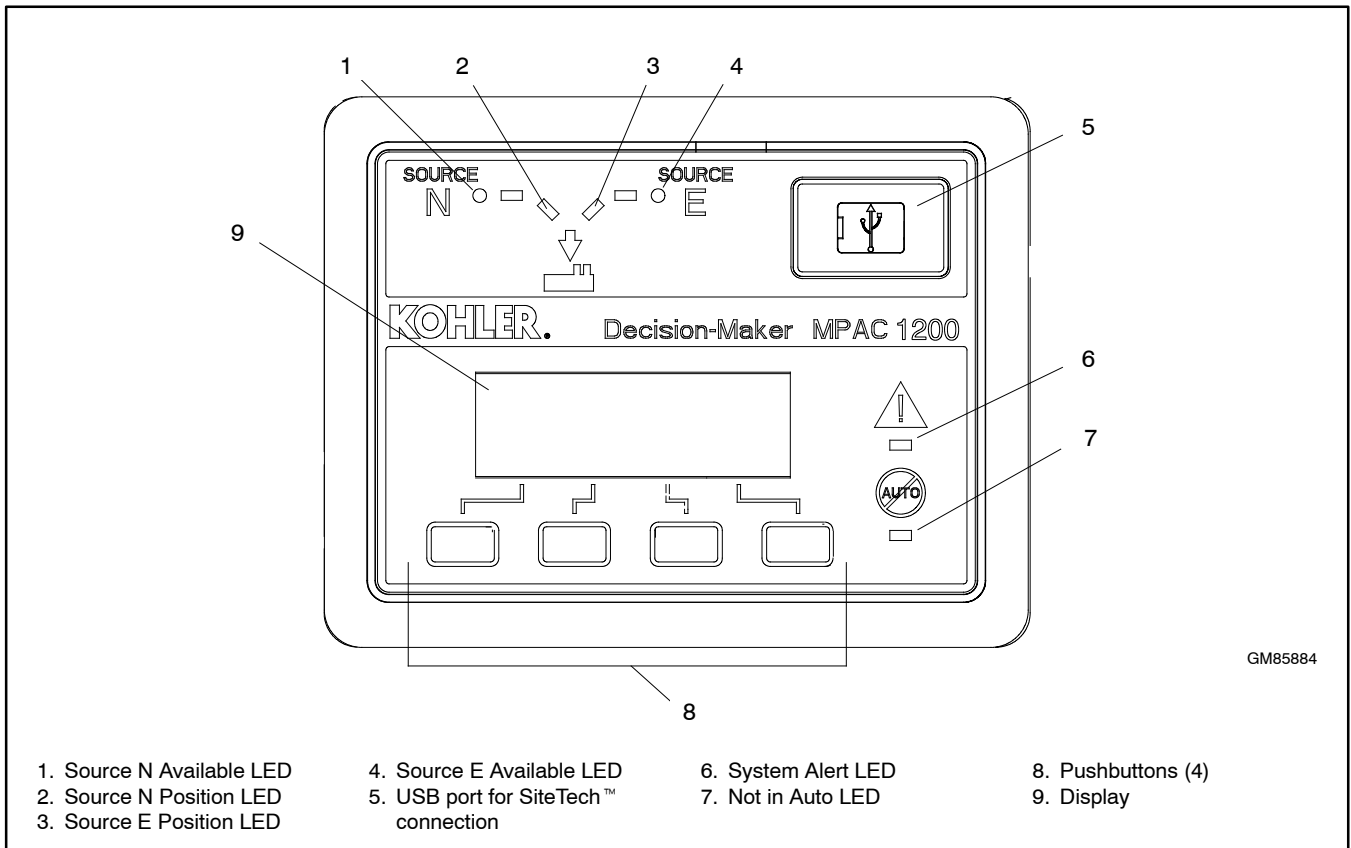

Figure 1-1 User Interface Panel

1.3.1 Display

The four-line display indicates transfer switch status and setup, including the following:

- System status
- Faults and warnings
- Active time delays
- Source voltages
- Source frequency (Hz)
- Current (amps)
- Source setup information
- Time and date
- Time and date of next scheduled exercise

The display also identifies the pushbutton functions, which can change from menu-to-menu.

1.3.2 Display Contrast

To adjust the display contrast, press and hold the second button until two rows of asterisks (*) appear. Then press the up arrow button to increase the contrast or the down arrow button to decrease the contrast. The display will return to the main menu after a few seconds if no buttons are pressed.

1.3.3 Pushbuttons

The user interface panel has four pushbuttons below the display. Pushbutton functions are shown above each button in the last line of the display and can change from menu-to-menu. The pushbutton functions are defined in Figure 1-2.

Note: The current can be set to zero (0) by pressing the first and last pushbuttons together. See section 4.13 for instructions.

▼	Down arrow (closed). Step down to the next menu or scroll through a list.
▲	Up arrow (closed). Step back to the previous menu.
▶	Right arrow (closed). Move to the next submenu.
△	Up arrow (open). Increases the selected numerical value.
▽	Down arrow (open). Decreases the selected numerical value.
▷	Right arrow (open). Steps to the next digit in a selected numerical value.
Back	Steps back to the previous menu or submenu.
End Delay	Ends the current time delay.
End Test	Ends an active test sequence. See Section 2.2.3.
OK	Enters the displayed numerical value (password or setting).
Main	Returns to the main menu.
Next	Steps to the next parameter in an item with multiple settings (for example, in Exerciser Setup).
Reset	Reset the fault condition shown on the display, or reset an accessory module after connection.
Save	Saves settings shown on the display.
Set	From the main menu, moves to the first setup menu.
Start	From the Test menu, starts the test sequence.
Test	From the main menu, moves to the test sequence menus. See Section 1.7.
View	From the main menu, moves to the first view menu.

Figure 1-2 Pushbutton Functions

1.3.4 LED Indicators

LEDs on the user interface indicate contactor position, source availability, faults, and other conditions. The table in Figure 1-3 describes the functions of the LED indicators.

See Section 1.10 for more information about warnings and faults.

Some programmable inputs will trigger the LEDs to light or flash. See Section 4.7.

LED Indicator	Condition
Source N Available, Green	Source N is available.
Source E Available, Red	Source E is available.
Position A, Green	Contactor is in Normal position.
Position B, Red	Contactor is in Emergency position.
System Alert, Red	Fault. Identify and correct the cause of the fault condition, then reset faults at the controller. See Section 1.10.
	Input active: Low Battery Voltage or Remote Common Alarm. See Section 4.7.
Not in Auto, Red	ATS is not set for automatic operation or a load shed (forced transfer to OFF) sequence is active.
	Flashes for manual transfer waiting.
	Input active: Inhibit Transfer, Forced Transfer to OFF. See Section 4.7.

Figure 1-3 User Interface LED Indicators

1.3.5 Lamp Test

To test the LEDs on the controller's user interface, go to the Main menu. Press the down arrow button once, then press the Lamp Test button and verify that the LCD menu and all 6 LEDs on the user interface illuminate. See Figure 1-4.

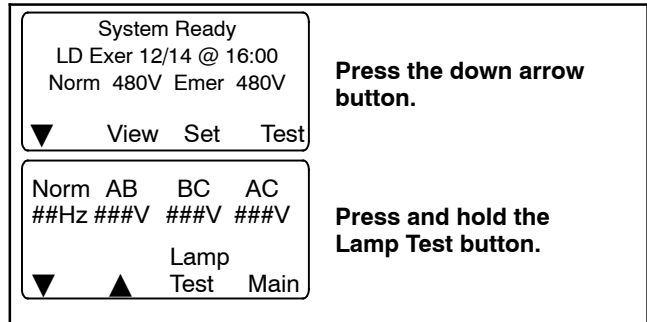

Figure 1-4 Lamp Test

1.3.6 Examples

Figure 1-5 illustrates navigation through the menus.

Figure 1-6 illustrates how to use the pushbuttons to step through menus and change settings. This example shows setting the time.

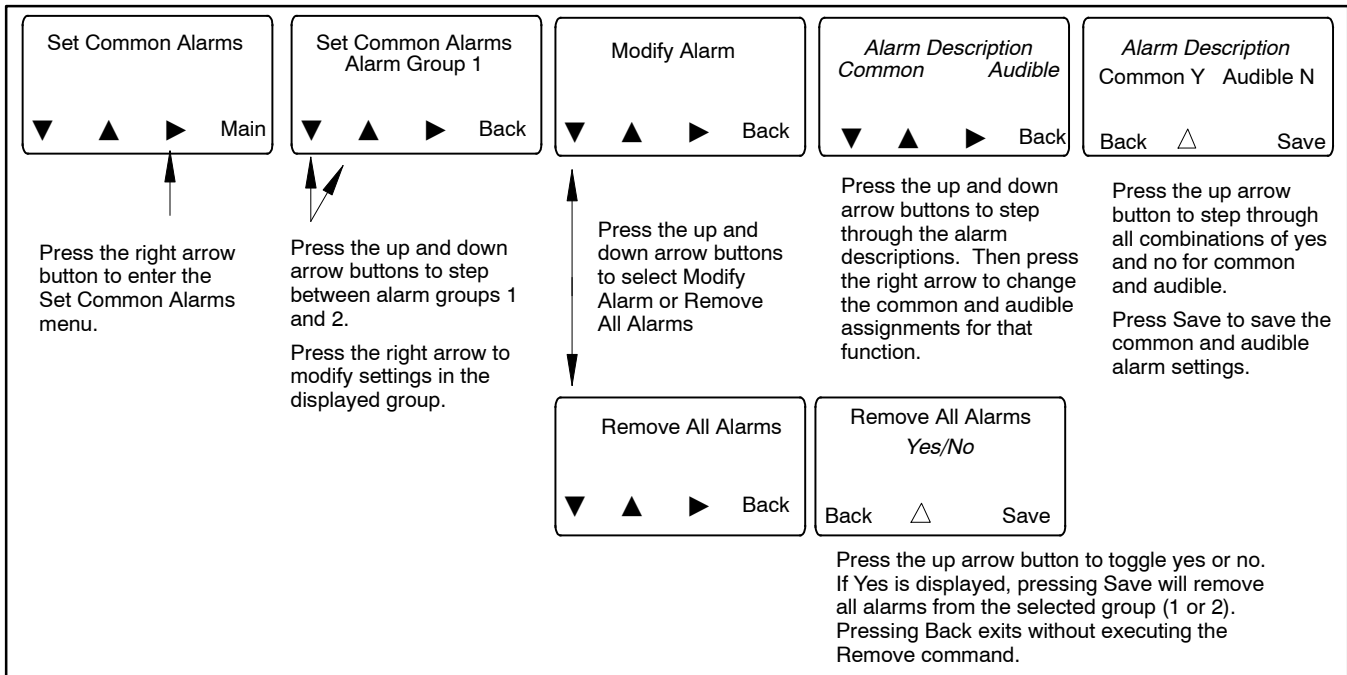

Figure 1-5 Example: Set Common Alarms

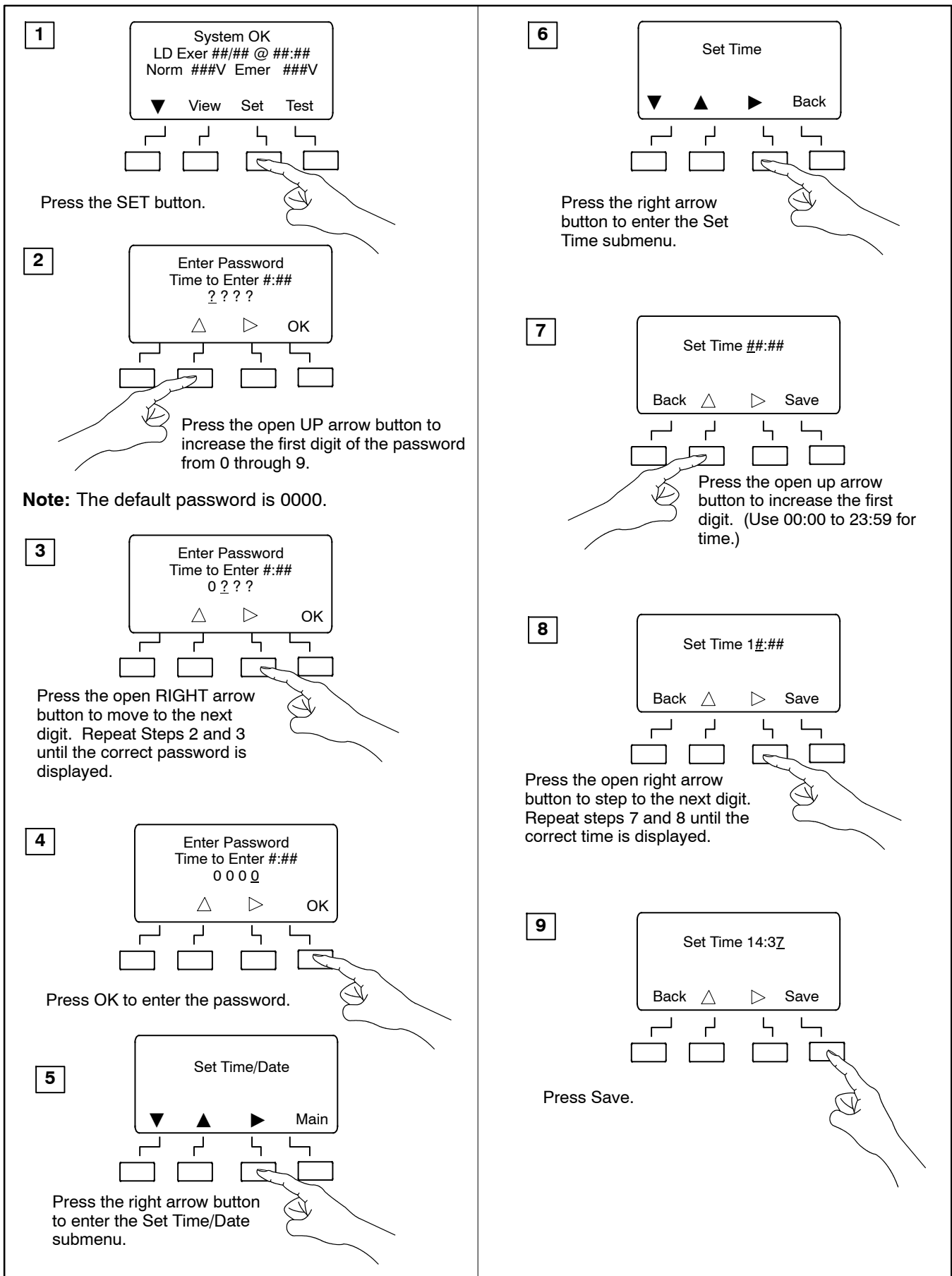

Figure 1-6 Example: Setting the Time

1.4 Main Menu

The main menu appears at system startup and displays the following information (see Figure 1-7):

- System Status (see Figure 1-8)
- Date and time of the next scheduled exercise run (if programmed)
- Measured source voltages
- Pushbutton functions

Pressing the down arrow button steps to the normal operation menus shown in Section 1.6. Step through these menus to check the measured frequency, line voltages, current (if the current sensing accessory is installed), and other system information.

Some parameters will appear only under certain conditions. For example:

- If no exercise runs are scheduled, the second line of the main menu is blank.
- The Daylight Saving Time settings are displayed only if DST is enabled.
- Phase rotation and in-phase monitoring are displayed only for three-phase systems.
- Some parameters and time delays appear only for programmed-transition models.
- The menus displayed during a test or exercise sequence will vary depending on the time delay settings.

Pressing the View button steps to the view menus shown in Section 3.3.

Passwords are required to enter the setup and test modes. See Section 1.5 for more information about passwords.

Press the Set button to enter the setup mode. A password is required. See Section 4.2 for system setup menus.

Press the Test button to enter the Test mode. A password is required. See Section 1.7.

The display returns to the main menu after 10 minutes of no activity (no buttons pressed).

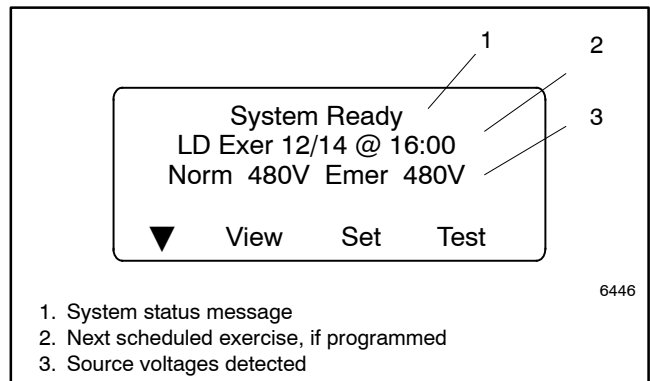

Figure 1-7 Main Menu

System Status Messages
Aux Switch Fault
Aux Switch Open
Exerciser Active
External Battery Low
Fail to Acquire Pref
Fail to Acquire Stby
Fail to Transfer
In Phase Waiting
Inhibit Transfer
Low Battery Voltage
Maint DIP Switch
Module Lost Comm
New Module
Peak Shave Active
Phase Rotation Error
Remote Common Alarm
System Ready
Test Mode Active

Figure 1-8 System Status Messages

1.5 Passwords

Passwords are required to enter the Test and Setup menus. Passwords are 4-digit numbers. See Figure 1-9 for instructions to enter the password using the pushbuttons on the controller's user interface.

There are two passwords:

Setup Password. The setup password controls access to the system setup menus, which allow changes to system settings, time delays, etc.

For closed-transition models, the setup password is required to initiate a transfer when the programmed transition override function is set to manual. See Section 1.7.3.

Test Password. The test password controls access to the test sequence menus. The test password is required to initiate a loaded, unloaded, or auto-loaded test, and also to initiate a sync check test on closed-transition models.

If the correct password is not entered within 30 seconds, the display returns to the main menu.

The factory default password is 0000. Change the password to allow only authorized personnel to start and end tests or change settings.

1.5.1 Changing Passwords

Use the Passwords Setup Menu to change passwords. See Section 4.11.

1.5.2 Test Password Reset and Disable

The test password can be reset to the default value or disabled. Use the Setup Menu- Reset Data menu. See Figure 1-26.

Note: Disable the test password only during service unless the transfer switch is located in a secure location.

Disabling the test password allows *any* user to initiate a test sequence from the controller's user interface without entering a password. Initiating a test starts the generator set and, if a loaded test is selected, transfers the load.

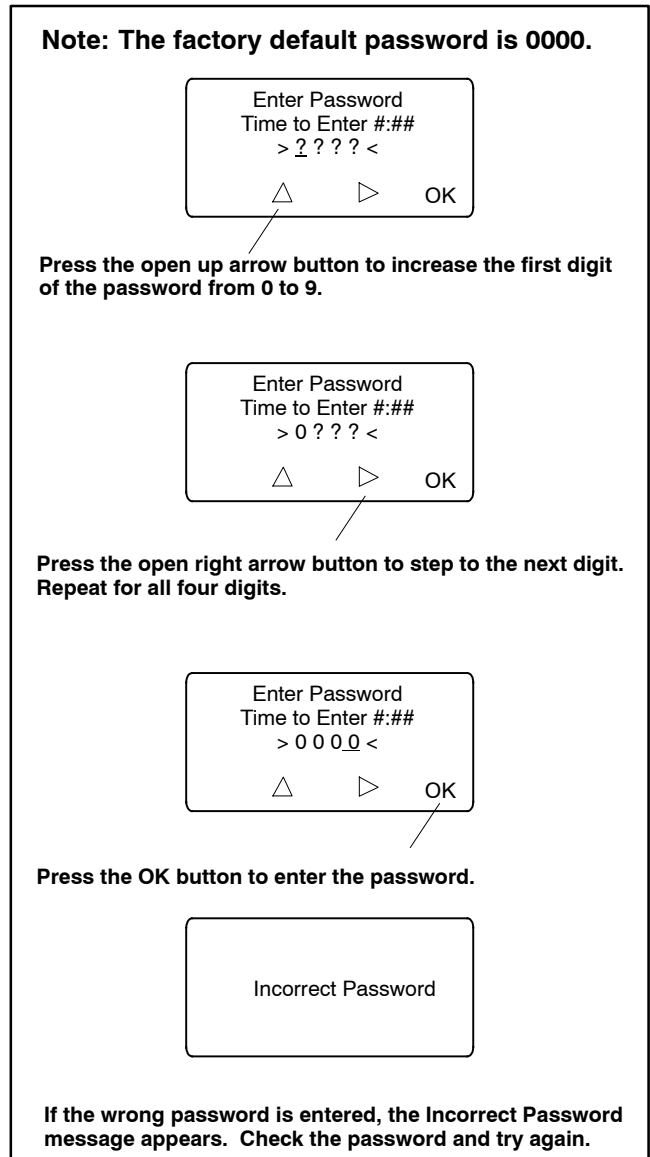

Figure 1-9 Entering a Password

1.6 Normal Operation Menus

During normal transfer switch operation, the screens shown in Figure 1-10 or Figure 1-11 are displayed. Use the up and down arrow buttons to view the system status information as shown. Press Main to return to the main menu from any screen.

The Sequence of Operation descriptions in Sections 2.2 through 2.4 describe the transfer switch normal operation for standard, programmed, and closed transition models.

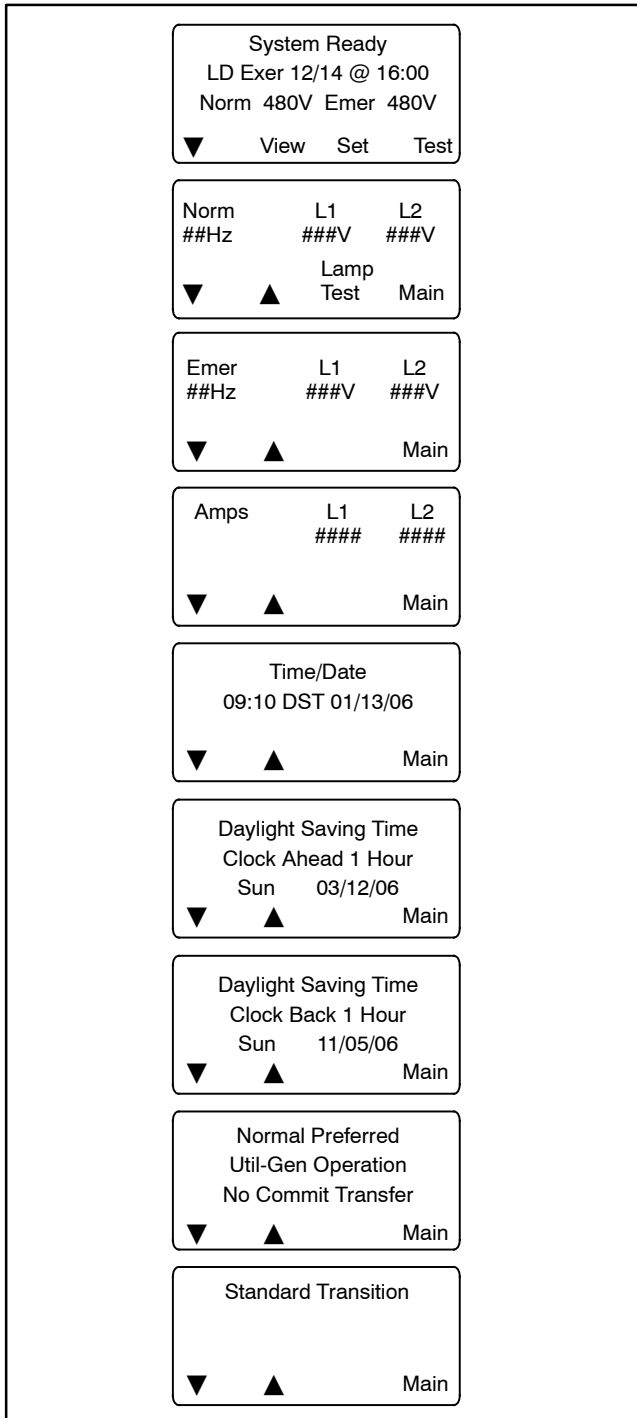

Figure 1-10 Single-Phase Operation

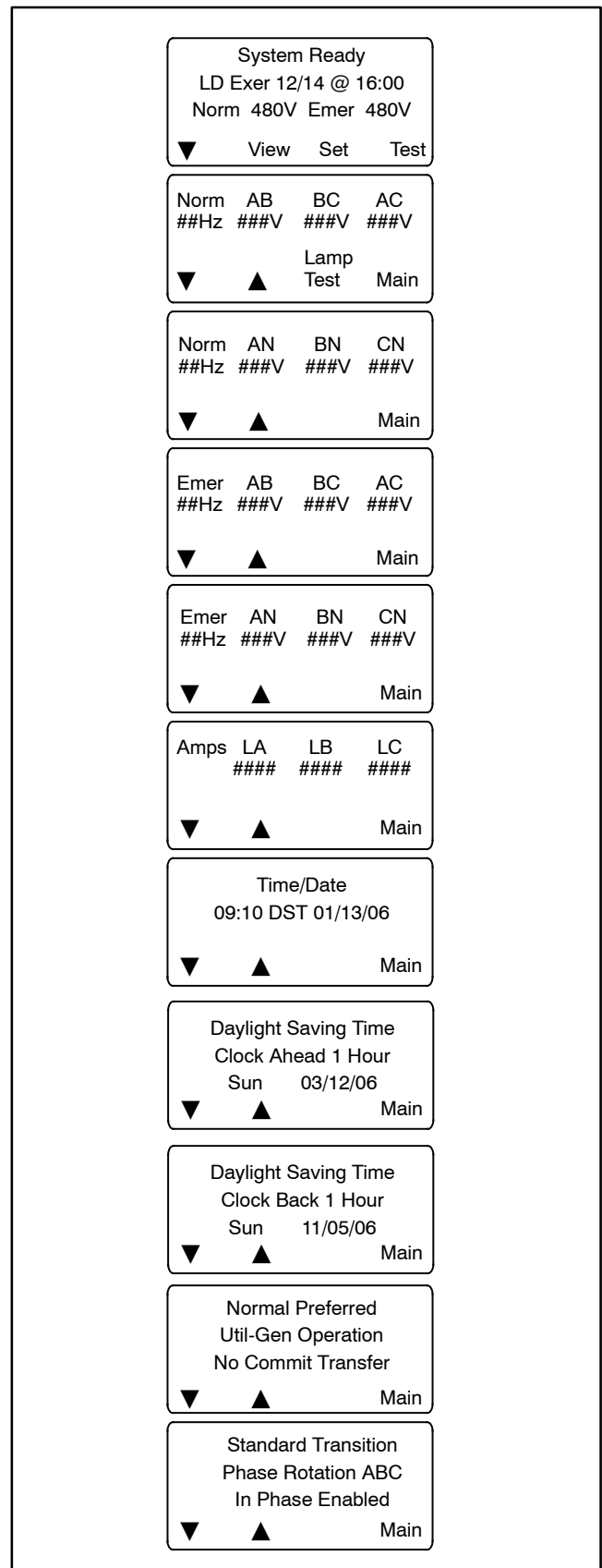

Figure 1-11 Three-Phase Operation

1.7 System Test

Use the system test feature to:

- Start and run the generator set.
- Simulate a preferred source failure, resulting in a transfer to the standby source.
- Check source synchronization (closed-transition models only).

See Figure 1-12 for the test sequence menus. From the main menu, press the Test button and then enter the password. The password ensures that only authorized personnel can start a test.

Press the down arrow button to navigate to the desired test sequence. Press the Start button to start the test.

Figure 1-13 shows the menus displayed during the test run. Menus are dependent on the system settings and

time delays. See Figure 1-16 for Sync Check menus for closed-transition models.

Press the End Test designated pushbutton to end the test. Time delays will execute as programmed when the test is ended. Press the End Delay button to end the currently displayed time delay, if desired.

To check the source voltage and frequency while a test is running, press the Main button. Press the Test button to return to the test sequence menus.

If the emergency source is lost during a system test, the fail to acquire standby signal is indicated immediately, and the test is terminated. If the contactor is in the standby position, it transfers immediately to the preferred position.

See Section 4.7.3 for additional information about the remote test input.

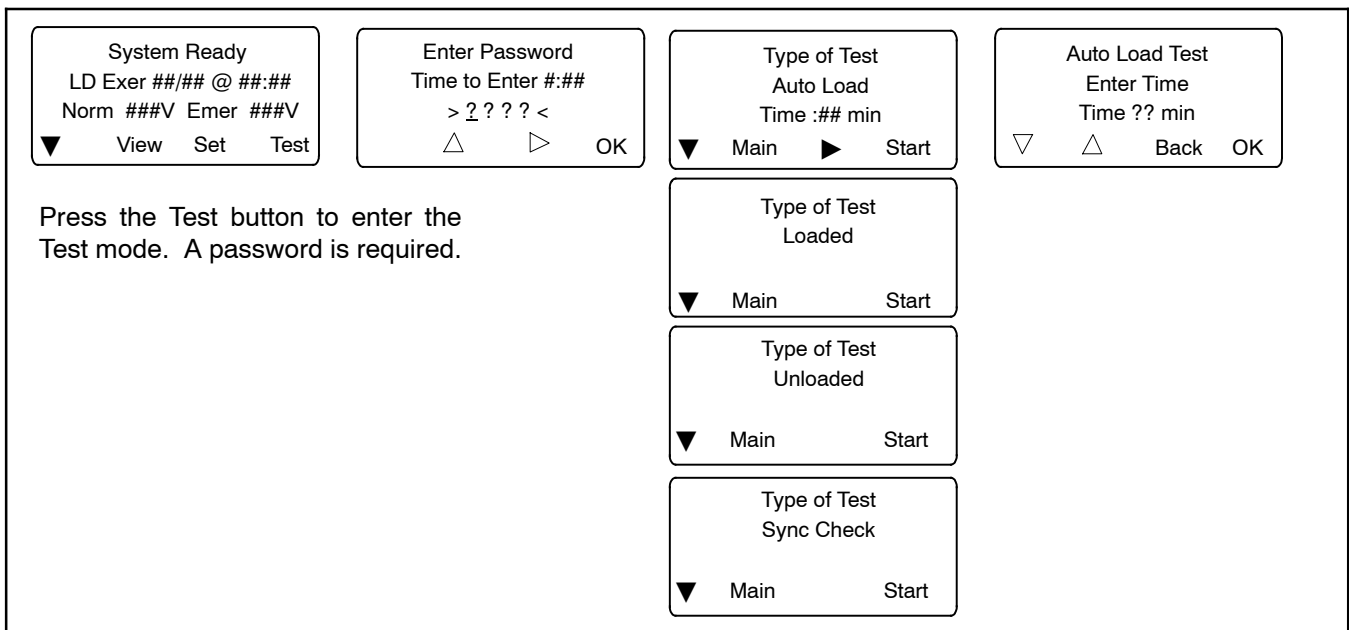

Figure 1-12 Test Selection Menus

<p>Engine Start in ##:## Norm ###V Emer ###V</p> <p>Main End End Delay Test</p>	
<p>LD# Disc in ##:## Norm ###V Emer ###V</p> <p>Main End End Delay Test</p>	Appears if load control time delays are set
<p>Xfr to Off in ##:## Norm ###V Emer ###V</p> <p>Main End End Delay Test</p>	Programmed-transition models only
<p>Xfr to Emer in ##:## Norm ###V Emer ###V</p> <p>Main End End Delay Test</p>	
<p>Add LD# in ##:## Norm ###V Emer ###V</p> <p>Main End End Delay Test</p>	Appears if load control time delays are set
<p>System on Test Norm ###V Emer ###V</p> <p>Main End End Delay Test</p>	
<p>LD# Disc in ##:## Norm ###V Emer ###V</p> <p>Main End End Delay Test</p>	Appears if load control time delays are set
<p>Xfr to Off in ##:## Norm ###V Emer ###V</p> <p>Main End End Delay Test</p>	Programmed-transition models only
<p>Xfr to Norm in ##:## Norm ###V Emer ###V</p> <p>Main End End Delay Test</p>	
<p>Add LD# in ##:## Norm ###V Emer ###V</p> <p>Main End End Delay Test</p>	Appears if load control time delays are set
<p>Eng Cooldown ##:## Norm ###V Emer ###V</p> <p>Main End End Delay Test</p>	
<p>Note: See Figure 1-16 for Sync Check menus.</p>	

Figure 1-13 Test Sequence Menus

1.7.1 Unloaded System Test

When an unloaded test is initiated, the controller immediately signals the generator to start, without waiting for the engine start time delay to expire. The contactor does not change position during an unloaded test, but if the normal source should fail, the contactor will transfer to the emergency source.

The load bank control output is active during an unloaded exercise or unloaded system test. If the contactor transfers to the standby position during the test, the load bank control is deactivated. (The standby source supplies power to the load.)

1.7.2 Loaded System Test

A loaded test simulates a preferred source failure, except that the engine start time delay is bypassed. The generator set is signaled to start immediately upon test activation. Load control signals are issued prior to transfer with their associated time delays. Since the loaded test transfer will be between two live sources, the in-phase monitor or closed transition feature will be activated if it is enabled. If the preferred source is lost during a loaded test with the contactor in the standby position, the test will continue to be active, even on restoration of preferred. If the standby source is lost and the preferred source is available, the test will be terminated, and the transfer switch will immediately transfer to the preferred source position, bypassing all time delays except the off-position requirements in a programmed-transition system.

When a loaded test is terminated normally, the retransfer sequence operates as though the preferred source has been restored after a failure. All time delays are executed and an in-phase transfer will occur if enabled. The loaded test feature is available with the Util-Genset, Util-Util and Genset-Genset modes of operation.

1.7.3 Closed-Transition Loaded Test

When a loaded test is initiated on a closed-transition model, the generator set is signaled to start and the controller monitors the sources for synchronization. The load is transferred when the sources are synchronized.

If the sources do not sync before the Fail to Sync time delay expires, the programmed-transition override function operates.

- If the override function is set to Automatic, a programmed-transition transfer will occur when the Fail to Sync time delay expires. The contactor stops in the OFF position for the length of the off-to standby time delay before proceeding to transfer to the standby source.
- If the override function is set to manual, the user can either initiate a programmed-transition type transfer (setup password required) or cancel the test sequence. See Figure 1-14. If neither action is taken, the controller will continue to check for synchronization and transfer if the sources synchronize.

See Section 4.9.3 for instructions to set the programmed-transition override function.

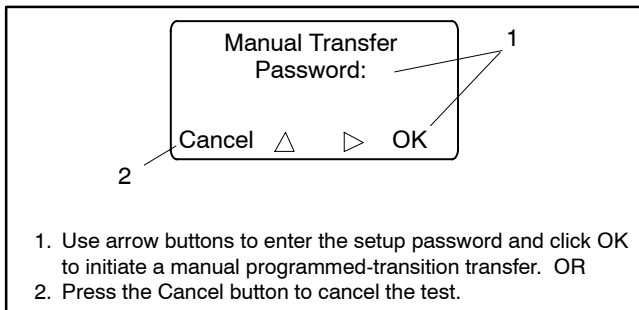

Figure 1-14 Manual Transfer Menu for Programmed-Transition Override

1.7.4 Auto-Loaded System Test

The auto-loaded test feature is a timed, loaded test. The auto-loaded time delay determines how long after the transfer to standby to terminate the test and transfer back to the preferred source. The time is defaulted to 30 minutes and can be adjusted from 1 minute to 60 minutes. See Figure 1-15.

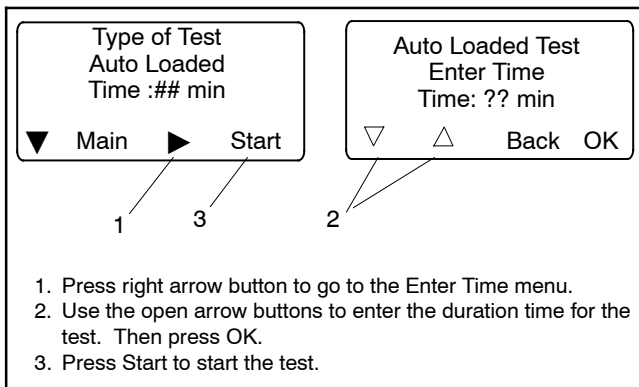

Figure 1-15 Auto Loaded Test Menus

1.7.5 Sync Check (closed-transition)

The Sync Check allows a test of the synchronization of two available sources without initiating a transfer. Navigate to the Type of Test, Sync Check menu and press the Start button to begin the test. The controller displays *Syncing* during the test, and the phase angle difference is shown between two arrows. For example, > 10 < indicates that the sources are 10 degrees out of phase. The arrows move closer together as the sources approach synchronization. When the sources synchronize, the controller indicates *Synced* and continues to monitor the source synchronization. The load is not transferred. See Figure 1-16. Press the End Test button to end the test.

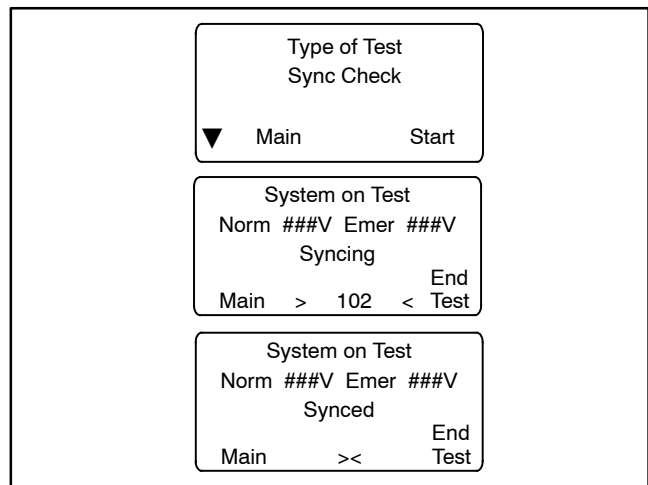

Figure 1-16 Sync Check Menus

1.8 Automatic Operation Test

Note: Close and lock the enclosure door before starting the test procedure.

Preferred Source Selection. The test procedure assumes that Source N is the preferred source. If the ATS is equipped with the alarm board accessory, check the preferred source selection before proceeding with the automatic operation test. To check the preferred source selection, use the down arrow button to step down from the main screen until Normal Preferred or Emergency Preferred is displayed. See Figure 1-10 or Figure 1-11.

Supervised Transfer Switch. If the transfer switch is equipped with a supervised transfer switch, verify that it is set to the Auto position.

Follow the procedure below to start a loaded test. Verify that the ATS starts the generator set and transfers the load to the emergency source, executing all time delays that are set up to operate during a loss of the normal source. End the test and verify that the transfer switch transfers the load back to the normal source and removes the engine start signal, executing all

appropriate programmed time delays. Refer to Section 2.2.3 for a more detailed description of the test sequence of operation.

Load control time delay settings may affect the operation sequences.

Note: If the standby source fails during a loaded test, the ATS will immediately attempt to transfer to the preferred source.

Automatic Operation Test Procedure

1. Check the controller LED indicators to verify that the Position N and Source N Available indicators are lit.
2. Verify that the generator set master switch is in the AUTO position.
3. Refer to Figure 1-17. From the main screen, press the Test button. Enter the test password when prompted and press OK.
4. Press the down arrow button to display Type of Test Loaded.
5. Press the Start button.
6. Verify that the generator set starts and the Source E Available LED lights.
7. Verify that the switch transfers the load to Source E. Observe the controller LEDs and display as the time delays execute and the load is transferred.
 - a. Standard-Transition Models: After the preferred-to-standby transfer time delay, verify that the Position N LED turns off and the Position E LED lights, indicating that the switch has transferred the load to Source E.
 - b. Programmed-Transition Models: After the preferred-to-off time delay, verify that the Position N LED turns off. After the off-to-standby time delay, check that the Position E LED lights, indicating that the switch has transferred the load to Source E.
 - c. Closed-Transition Models: See Section 1.7.3. After the preferred-to-standby time delay, the controller monitors the sources for synchronization. When the sources are in sync, the ATS transfers the load to Source E and the Position E LED lights. Both sources will be connected for less than 100 milliseconds before Source N is disconnected and the Position N LED turns off.

If the sources do not synchronize before the fail to sync time delay expires, operation depends on the programmed transition override setting. If automatic override is enabled, the ATS will transfer the load using a programmed-transition transfer. If automatic override is not enabled, the ATS will continue to monitor the source synchronization and transfer when/if the sources synchronize. The operator can initiate a programmed-transition transfer (password required) or cancel the transfer.

8. Press the End Test button.
9. Verify that the switch transfers the load back to Source N.
 - a. Standard-Transition Models: After the standby-to-preferred time delay, verify that the Position E LED goes out and the Position N LED lights, indicating that the switch has transferred the load to Source N.
 - b. Programmed-Transition Models: After the standby-to-off time delay, verify that the Position E LED goes out. After the off-to-preferred time delay, check that the Position N LED lights, indicating that the switch has transferred the load to Source N.
 - c. Closed-Transition Models: See Section 1.7.3. After the standby-to-preferred time delay, the controller monitors the sources for synchronization. When the sources are in sync, the ATS transfers the load to Source N and the Position N LED lights. Both sources will be connected for less than 100 milliseconds before Source E is disconnected and the Position E LED turns off.
10. After the engine cooldown time delay expires, the engine start signal is removed. Verify that the generator set stops.

If the sources do not synchronize before the fail to sync time delay expires, operation depends on the programmed transition override setting. If automatic override is enabled, the ATS will transfer the load using a programmed-transition transfer. If automatic override is not enabled, the ATS will continue to monitor the source synchronization and transfer when/if the sources synchronize. The operator can initiate a programmed-transition transfer (password required).

Note: The generator set may have an engine cooldown time delay that causes the generator set engine to run after the transfer switch engine start signal is removed.

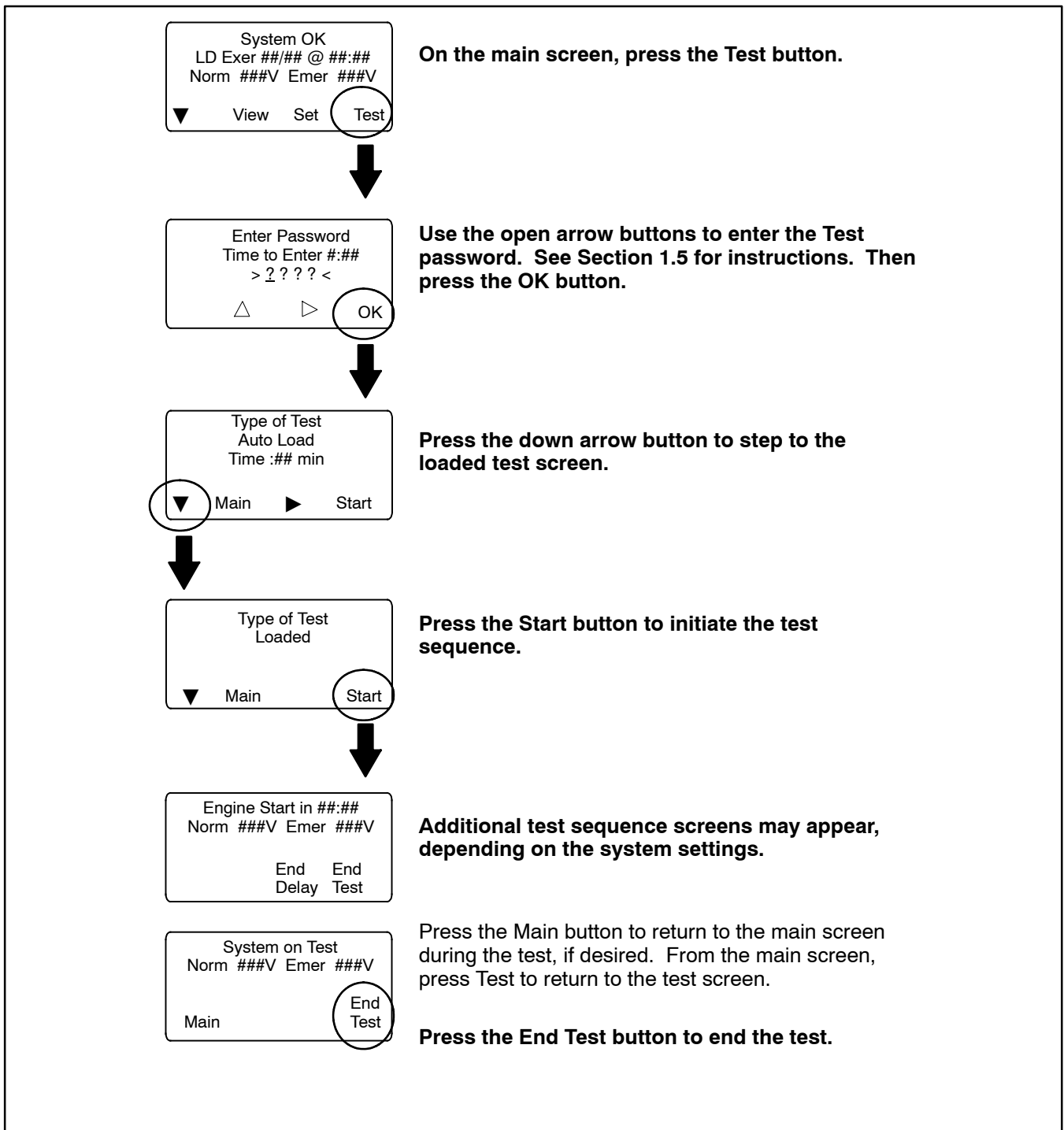

Figure 1-17 Starting and Stopping the Automatic Operation Test

1.9 Exercise

Schedule exercise runs through the Set Exercise menus. See Section 4.4. To run the generator set at a time other than a scheduled exercise sequence, use the Test function. See Section 1.7 for instructions.

When a scheduled exercise is running, the menus shown in Figure 1-18 appear. Press Main to return to the main menu, if desired. Press the End button to end the exercise sequence before the scheduled stop time, if necessary.

If a system test or peak shave is active when the exercise is scheduled to occur, the exercise is skipped. A preferred-source failure during an exerciser period causes the exercise to be terminated and normal ATS operation to resume.

An exercise event can be temporarily disabled to prevent its execution and then re-enabled later using the enable/disable setting in the Set Exercise menus. See Section 4.4.

1.9.1 Unloaded Exercise

An unloaded exercise starts and runs the generator set without transferring the load.

1.9.2 Load Bank Control

The load bank control output is active during an unloaded exercise or unloaded system test. If the

contactor transfers to the standby position, the load bank control will be deactivated. (The standby source supplies power to the load.)

1.9.3 Loaded Exercise

A loaded exercise starts the generator set and transfers the load from the normal source to the standby source.

On closed-transition models, transfer will occur when the sources are synchronized. If the sources do not sync, press Cancel to end the exercise.

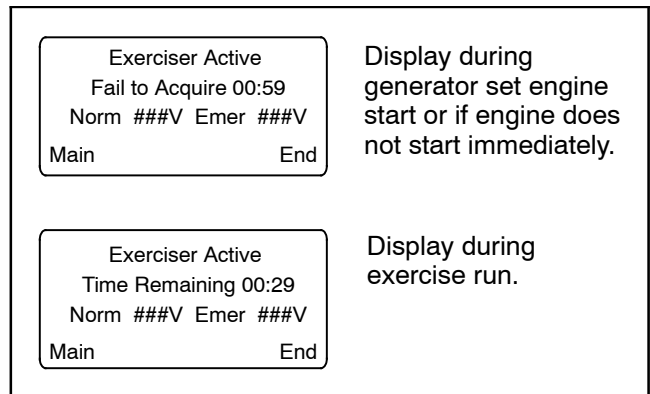

Figure 1-18 Exercise Sequence Menus

1.10 Warnings and Faults

When a fault exists, the System Alert indicator flashes, a designated output and the common fault output are turned on, and an appropriate message is displayed to indicate the fault. See Figure 1-19 for the location of the System Alert indicator.

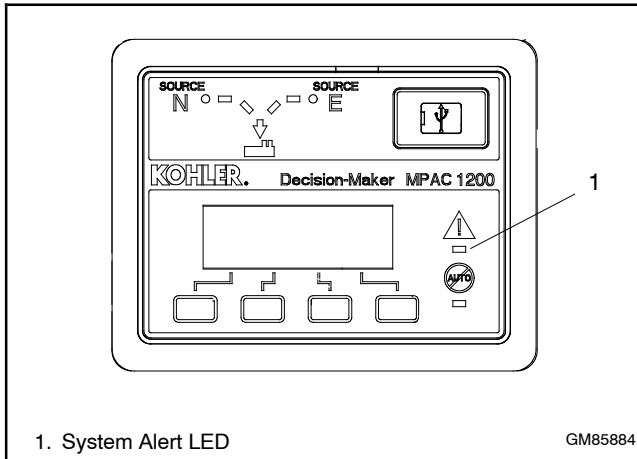

Figure 1-19 Fault Indication

ATS warnings and faults are shown in Figure 1-20. There are three types of warning/fault conditions:

Warning. Warnings automatically reset with a source availability change or a transfer request.

Fault Requiring Manual Reset. Under these conditions, normal ATS operation is halted. Active modes are turned off. If the contactor is in the preferred source position, the engine cooldown time delay executes and the engine start contacts open, allowing the generator set to shut down. See Section 1.10.1 for instructions to reset faults.

Self Resetting Faults. Under these conditions, active modes are turned off. If the contactor is in the preferred source position, the engine cooldown time delay executes and the engine start contacts open, allowing the generator set to shut down. When the fault condition is corrected, the fault is automatically cleared from the controller and normal ATS operation continues.

Condition	Type	Description
Failure to Acquire Standby Source	Warning	The source voltage did not reach the acceptable range within a set time (see Time Delays). For example, the standby source generator set did not start.
Failure to Acquire Preferred Source	Warning	
IPM Synching (In-Phase Monitor Synching)	Warning (status)	The two sources did not come into phase within the Fail to Synchronize time delay. Note: If the sources do come into phase after the time delay expires, the warning is automatically cleared and normal ATS operation continues.
External Battery Low	Warning	The voltage of the battery connected to the external battery supply module (EBSM) is low.
Failure to Transfer	Warning	The signal to transfer is sent to the contactor and the main shaft auxiliary switch fails to indicate a complete ATS position change. The controller will attempt to transfer the unit three times before the fault is indicated.
Src N (or Src E) Rotation Err	Self-Resetting Fault	The detected phase rotation of one or both sources does not match the preselected setting.
I/O Module Lost Comm	Self-Resetting Fault	An I/O device has stopped communicating or does not have a correct address specified. Fault resets if communication is reestablished.
Auxiliary Switch Fault	Manual Reset Fault	The main shaft auxiliary switches indicate that the ATS is in more than one position, or the position changed when no signal was sent to initiate the change.
Auxiliary Switch Open	Manual Reset Fault	The main shaft auxiliary switches indicate that the ATS is in neither position (all inputs are open).
Module Status Change	Manual Reset Fault	An accessory module has been disconnected OR a new module is detected. See Section 1.11.1 to reset.
Module Status Conflict	Manual Reset Fault	An accessory module has been replaced with a different type of module with the same address. See Section 1.11.2 to reset.
External Fault	Self-Resetting Fault	The external input dedicated to this condition is closed.

Figure 1-20 Warnings and Faults

1.10.1 Fault Reset

To clear a fault or warning condition and reset the System Alert LED, go to the Main menu and press the down arrow button to open the Reset menu. See Figure 1-19 and Figure 1-21. Then press the button labeled Reset. A fault reset does not change the controller settings.

See Section 1.11, Accessory Module Faults, for instructions to correct and reset faults related to the I/O modules and other accessory modules.

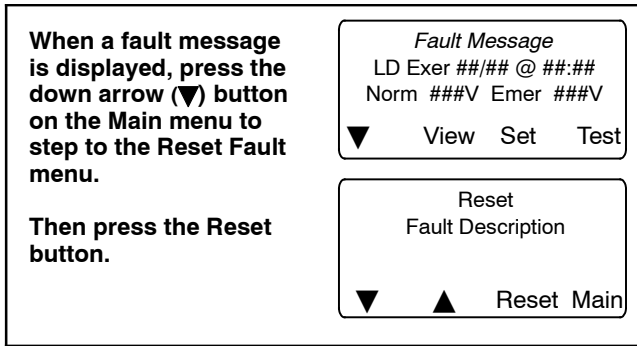

Figure 1-21 Fault Reset

1.11 Accessory Module Faults

Accessory modules are optional equipment.

1.11.1 Module Status Change

Connecting or disconnecting one or more accessory modules can cause the Module Status Change message to be displayed.

Module Connection (new or reconnected module)

Installing or reconnecting one or more accessory modules triggers the Module Status Change message. See Figure 1-22. Press the Reset button to display Reset New Module. Press the Reset button from that menu. The controller recognizes the module type(s). See Figure 1-23.

Navigate to the Set Input/Outputs>Set Aux I/O menu to check that the controller has recognized the connected modules.

See Section 4.7 for instructions to assign programmable inputs and outputs to I/O modules. Go to Section 4.8 for instructions to assign functions to the audible alarm for an Alarm Module.

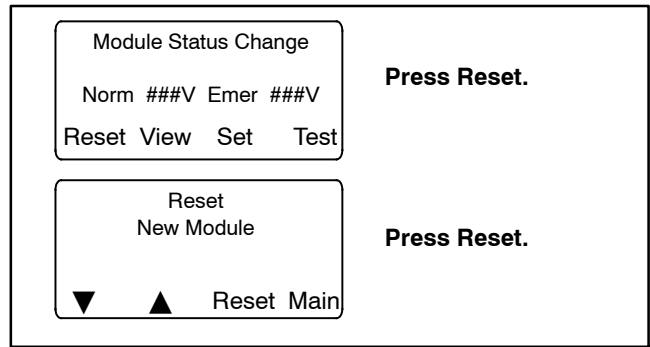

Figure 1-22 Menus after Module Connection

Module Type	Description
AOB	Switch/Alarm Module (alarm option board)
SOB	Standard I/O Module (standard option board)
POB	High-Power I/O Module (power option board)

Figure 1-23 Module Types

Disconnected Module

If one or more accessory modules are disconnected from the controller, the message Module Status Change appears. See Figure 1-24. Pressing the Reset button displays the message Check Module Setup to Clear Fault. Use the following Module Uninstall Procedure to uninstall modules after disconnection.

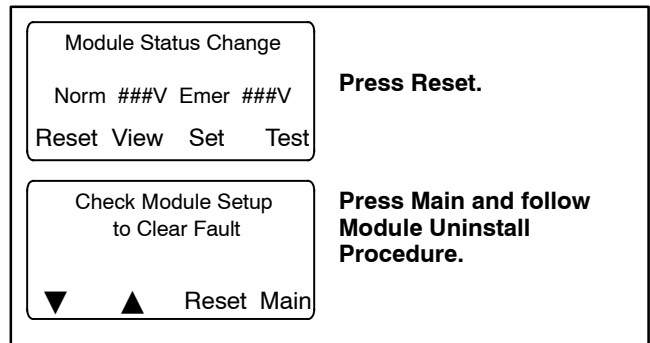

Figure 1-24 Menus after Module Disconnection

Module Uninstall Procedure

1. Press Main to return to the main menu.
2. Press Set to enter setup mode.
3. Enter the setup password.
4. Press the down arrow to step to the Set Inputs/Outputs menu.
5. Navigate to the Set Auxiliary I/O menu. See Figure 1-25. Press the right arrow button to see the status of module 1. Press the down arrow to step to the next module, if necessary, until the menu shows Status: Lost.
6. Press the right arrow button to move to the Uninstall Module menu. Verify that the menu says Uninstall Module Yes. (Press the open arrow button to toggle no/yes, if necessary.)
7. When Yes is displayed, press Save to uninstall the module.
8. Repeat the uninstall procedure for additional modules, if necessary.

Other Module Status Change Conditions

A *Module Status Change* message that cannot be cleared as described in this section may indicate a failure of the controller's real-time clock. Carefully follow the Module Connection or Module Uninstall procedures to attempt to reset the fault. If the fault cannot be reset, the controller's logic board may need to be replaced. Contact an authorized distributor/dealer for service.

1.11.2 Module Status Conflict

The message *Module Status Conflict* appears if one type of module is replaced with another type of module that has the same address. Follow the procedure below to resolve the conflict.

Procedure to Clear a Module Status Conflict

1. Disconnect power to the transfer switch.
2. Disconnect the module.
3. Close the enclosure door and reconnect power to the ATS. The display will show *Module Status Change*.
4. Press the button labeled Reset. The display will show Check Module Setup to Clear Fault.
5. Follow the procedure in Section 1.11.1 to uninstall the module through the ATS controller keypad.
6. Disconnect power to the ATS.
7. Connect the new module.
8. Close the enclosure door and reconnect power to the ATS. The display will show *Module Status Change*. See Figure 1-22.
9. Press the button labeled Reset to display *Reset New Module*. Press the reset button from that menu. The controller will now recognize the new module type.
10. Navigate to the Set Auxiliary I/O menu to check the status and settings for the new module. See Figure 1-25. Press the right arrow button to see the status of module 1. Press the down arrow to step to the next module, if necessary,

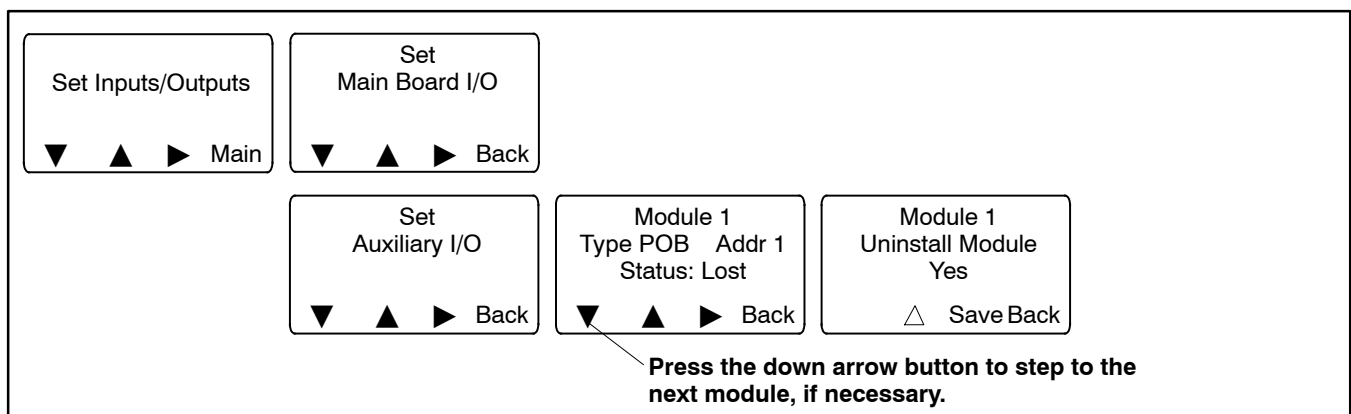

Figure 1-25 Uninstall Module

1.12 Reset Data

Be sure to read and understand the information in this section before resetting records or parameters.

Note: Resetting to the default parameters will reset **all** parameters to a factory default setting.

Use the Reset Data menus to set records or parameters back to factory default settings. See Figure 1-26.

1. Use the black arrow buttons to step to the desired menu.
2. Press the open up arrow button to toggle Yes or No until Yes is displayed.
3. Press Save to reset the records or parameters to the factory defaults. Pressing Back exits the menu without resetting.

1.12.1 Reset Maintenance Records

Reset the maintenance records after transfer switch service to update the last maintenance date and totals since reset that are displayed in the maintenance records menu.

1.12.2 Reset Event History

Resetting the event history **clears** the events from the event history log. The history lists the 100 most recent transfer switch events, including transfers and DIP switch setting changes as well as faults and alarms.

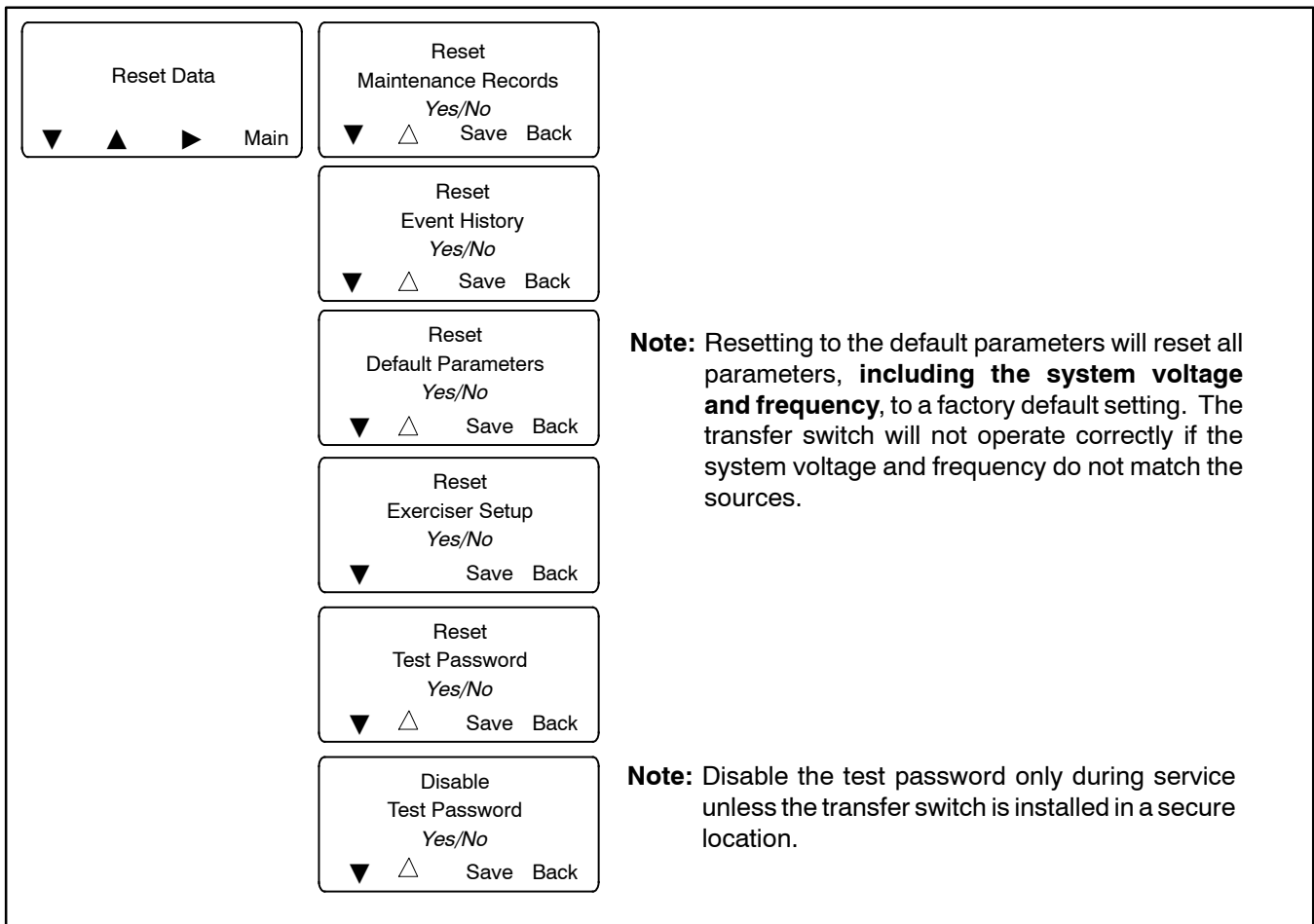

Figure 1-26 Reset Data

1.12.3 Reset Default Parameters

Resetting to the default parameters will reset **all** parameters, **including the system voltage and frequency**, to a factory default setting. The default system voltage and frequency settings may not match the settings for your application.

The transfer switch will not operate correctly if the system voltage and frequency do not match the sources. Use the Set Sources menu to set the system voltage and frequency after resetting to the default parameters. See Section 6 for instructions.

Check the system operation to verify the settings after resetting.

1.12.4 Reset and Disable Test Password

Reset the Test password to return the test password to the default, 0000.

Note: Disable the test password only during service unless the transfer switch is installed in a secure location.

Disabling the test password allows *any* user to initiate a test sequence from the controller's user interface without entering a password. Initiating a test starts the generator set and, if a loaded test is selected, transfers the load.

Section 2 Sequence of Operation

This section explains the transfer switch sequence of operation during the following events:

- Controller power-up or reset
- Preferred source loss and return
- Test
- Exercise
- Emergency source loss and return

The Sequence of Operation descriptions in Sections 2.2 through 2.4 describe the transfer switch normal operation for standard, programmed, and closed transition models. Operation can be affected by faults such as the normal or emergency contacts failing to open or close when signaled to do so.

2.1 Controller Power-up/Reset

Following is an explanation of the sequence of operation for the MPAC® 1200 ATS Controller when power is initially applied to the controller or a controller reset occurs.

1. Controller self test is executed.
2. System parameters are downloaded from nonvolatile memory.
3. Contactor position and source availability are determined.
4. If neither source is acceptable, the contactor does not change position.
5. If both sources are available, the controller immediately transfers the contactor to the preferred source.
6. If only one source is available, the controller immediately transfers the contactor to that source, executing only the off-position and load control time delays.

If the available source is the preferred source, and the contactor is in the standby position, the contactor transfers to preferred, the engine cooldown time delay runs, and then the engine start contacts open.

If the available source is the preferred source and the contactor is already in the preferred position, the engine start contacts open immediately, bypassing the engine cooldown time delay.

2.2 Sequence of Operation, Standard Transition Models

Operation can be affected by faults such as the normal or emergency contacts failing to open or close when signaled to do so.

2.2.1 Preferred Source Loss and Return, Standard Transition

Following is an explanation of the transfer switch sequence of operation when Preferred Source failure is detected.

Preferred Source Fails

1. Load control contacts open.
2. Engine start time delay expires.
3. The generator is signaled to start.
4. The generator starts and the standby source becomes available.
5. Preferred-to-standby time delay expires.
6. Contactor transfers to standby.
7. Post-transfer load control sequences run.
8. Load control contacts close.

Preferred Source Returns

1. Standby-to-preferred and pre-transfer load control time delays expire.
2. Load control contacts open.
3. Contactor transfers to preferred source.
4. Post-transfer load control sequences and engine cooldown time delay expire.
5. Load control contacts close.
6. The engine start contacts open, signaling the generator to stop.

2.2.2 Exerciser Operation, Standard Transition

Unloaded Exercise Sequence Starts

1. Exerciser timer begins.
2. The generator is signaled to start.
3. The generator starts and the standby source becomes available.
4. The load bank control is activated.

Unloaded Exercise Sequence Ends

1. The load bank control is deactivated.
2. Engine cooldown time delay expires.
3. The engine start contacts open, signaling the generator to stop.

Loaded Exercise Sequence Starts

1. Exerciser timer begins.
2. The generator is signaled to start.
3. The generator starts and the standby source becomes available.
4. Preferred-to-standby time delay and pre-transfer load control sequences run.
5. Load control contacts open.
6. Contactor transfers to standby.
7. Post-transfer load control sequences run.
8. Load control contacts close.

Emergency Source Fails (Normal Source is available)

1. Exerciser is deactivated.
2. Load control contacts open.
3. Contactor immediately transfers to preferred.
4. Immediate failure to acquire standby alarm.
5. Post-transfer load control sequences and engine cooldown time delay expire.
6. Load control contacts close.
7. Engine start contacts open.

Loaded Exercise Sequence Ends

1. Pre-transfer load control sequences run.
2. Load control contacts open.
3. Contactor transfers to preferred.
4. Post-transfer load control sequences and engine cooldown time delay expire.
5. Load control contacts close.
6. The engine start contacts open, signaling the generator to stop.

2.2.3 Test Sequence, Standard Transition

Unloaded Test Function is Initiated

1. The generator set is signaled to start.
2. The generator starts and the standby source becomes available.
3. The load bank control is activated.

Unloaded Test Function is Ended

1. The load bank control is deactivated.
2. Engine cooldown time delay expires.
3. The generator is signaled to stop.

Loaded Test Function is Initiated

1. The generator is signaled to start (engine start contacts close).
2. The generator starts and the standby source becomes available.
3. Pre-transfer load control time delays expire and load control contacts open.
4. Preferred-to-standby time delay expires.
5. Contactor transfers to standby.
6. Post-transfer load control time delays expire and load control contacts close.

Emergency Source Fails (Normal Source is available)

1. Test function is deactivated.
2. Load control contacts open.
3. Contactor immediately transfers to preferred.
4. Immediate failure to acquire standby alarm.
5. Post-transfer load control sequences and engine cooldown time delay expire.
6. Load control contacts close.
7. Engine start contacts open.

Loaded Test Function is Ended

1. Standby-to-preferred time delay and pre-transfer load control sequences run.
2. Load control contacts open.
3. Contactor transfers to preferred.
4. Post-transfer load control sequences and engine cooldown time delay expire.
5. Load control contacts close.
6. The engine start contacts open, signaling the generator to stop.

2.3 Sequence of Operation, Programmed-Transition

Programmed-transition models operate with a pause in the off position during transfer. The time in the off position is set through the off-to-standby and off-to-preferred time delays.

Operation can be affected by faults such as the normal or emergency contacts failing to open or close when signaled to do so.

2.3.1 Preferred Source Loss and Return, Programmed Transition

Preferred Source Fails

1. Load control contacts open.
2. Engine start time delay expires.
3. The generator is signaled to start (engine start contacts close).
4. The generator starts and the standby source becomes available.
5. Preferred-to-standby time delay expires.
6. Contactor transfers to OFF position.
7. Off-to-standby time delay expires.
8. Contactor transfers to standby source.
9. Post-transfer load control sequences run.
10. Load control contacts close.

Preferred Source Returns

1. Standby-to-preferred and pre-transfer load control time delays expire.
2. Load control contacts open.
3. Contactor transfers to OFF position.
4. Off-to-preferred time delay expires.
5. Contactor transfers to preferred source.
6. Post-transfer load control sequences and engine cooldown time delay expire.
7. Load control contacts close.
8. The generator is signaled to stop (engine start contacts open).

2.3.2 Exerciser Operation, Programmed Transition

Unloaded Exercise

The unloaded exercise sequence is the same as for standard transition. See Section 2.2.2.

Loaded Exercise Sequence Starts

1. Exerciser timer begins.
2. The engine start contacts close, signaling the generator set to start.
3. The generator starts and the standby source becomes available.
4. Preferred-to-standby time delay and pre-transfer load control sequences run.
5. Load control contacts open.
6. Contactor transfers to OFF position.
7. Off-to-standby time delay expires.
8. Contactor transfers to standby source.
9. Post-transfer load control sequences run.
10. Load control contacts close.

Emergency Source Fails (Normal Source is available)

1. Exerciser is deactivated.
2. Immediate failure to acquire standby alarm.
3. Load control contacts open.
4. Contactor transfers to OFF position.
5. Off-to-preferred time delay expires.
6. Contactor transfers to preferred source.
7. Post-transfer load control sequences and engine cooldown time delay expire.
8. Load control contacts close.
9. Engine start contacts open.

Loaded Exercise Sequence Ends

1. Pre-transfer load control sequences run.
2. Load control contacts open.
3. Contactor transfers to OFF position.
4. Off-to-preferred time delay expires.
5. Contactor transfers to preferred source.
6. Post-transfer load control sequences and engine cooldown time delay expire.
7. Load control contacts close.
8. The engine start contacts open, signaling the generator to stop.

2.3.3 Test Sequence, Programmed Transition

Unloaded Test Sequence

The unloaded test sequence is the same as for standard transition. See Section 2.2.3.

Loaded Test Sequence is Initiated

1. The generator is signaled to start (engine start contacts close).
2. The generator starts and the standby source becomes available.
3. Pre-transfer load control time delays expire and load control contacts open.
4. Preferred-to-standby time delay expires.
5. Contactor transfers to the OFF position.
6. Off-to-standby time delay expires.
7. Contactor transfers to standby.
8. Post-transfer load control time delays expire and load control contacts close.

Emergency Source Fails (Normal Source is available)

1. Test function is deactivated.
2. Immediate failure to acquire standby alarm.
3. Load control contacts open.
4. Contactor moves to the OFF position.
5. Off-to-preferred time delay expires.
6. Contactor transfers to preferred.
7. Post-transfer load control sequences and engine cooldown time delay expire.
8. Load control contacts close.
9. Engine start contacts open.

Loaded Test Sequence is Ended

1. Standby-to-preferred time delay and pre-transfer load control sequences run.
2. Load control contacts open.
3. Contactor moves to the OFF position.
4. Off-to-preferred time delay expires.
5. Contactor transfers to preferred.
6. Post-transfer load control sequences and engine cooldown time delay expire.
7. Load control contacts close.
8. The engine start contacts open, signaling the generator to stop.

2.4 Sequence of Operation, Closed-Transition Models

Closed-transition transfer switches operate with no interruption of power to the load during transfer when both sources are available. The controller monitors the sources for synchronization before initiating transfer. Sources are paralleled for less than 100 milliseconds during transfer. (See Section 2.4.5, Extended Transfer Time Relay.)

Operation can be affected by faults such as the normal or emergency contacts failing to open or close when signaled to do so.

2.4.1 Preferred Source Loss and Return, Closed Transition

Preferred Source Fails

1. Load control contacts open.
2. Engine start time delay runs and expires.
3. The generator is signaled to start (engine start contacts close).
4. The generator starts and the standby source becomes available.
5. Preferred-to-standby time delay expires.
6. Preferred source contacts open.
7. Off-to-standby time delay expires.
8. Emergency power contacts close.
9. Post-transfer load control sequences run and load control contacts close, as programmed through the Load Add settings.

Preferred Source Returns

1. Standby-to-preferred and pre-transfer load control time delays expire.
2. Load control contacts open according to the Load Disconnect time delay settings.
3. Check/wait for source synchronization.

Note: If the sources do not synchronize before the Fail to Sync time delay expires, the programmed-transition override function operates. See Section 2.4.2.

4. When sources are synchronized, preferred source contacts close.

5. Standby source contacts open within 100 milliseconds.

Note: If the standby source contacts do not open within 100 ms, the extended transfer time relay trips the standby source breaker.

6. Post-transfer load control sequences and engine cooldown time delay expire.
7. Load control contacts close as programmed through the Load Add settings.
8. The generator is signaled to stop (engine start contacts open).

2.4.2 Failure to Synchronize (Programmed-Transition Override)

If the sources do not synchronize before the Fail to Sync time delay expires, the programmed-transition override function can initiate a transfer. The override function transfers to the other source using programmed-transition mode, which causes an interruption in power to the load during transfer. The contactor stops in the OFF position for a programmed period of time, which is set by the off-to-preferred or off-to-standby time delay. The override function can be set to operate automatically or to require manual activation.

- If Automatic programmed-transition override is selected, a programmed-transition transfer will be initiated automatically when the Fail to Sync time delay expires.
- If Manual programmed-transition override is selected, an operator can initiate a programmed-transition transfer by entering the setup password and pressing a button after the Fail to Sync time delay expires. If a manual transfer is not initiated, the controller continues to monitor the sources and transfers if synchronization occurs.

See Section 4.9, Set System, to set the programmed-transition override function to automatic or manual. See Section 4.5, Time Delays, to set the off-to-preferred and off-to-standby time delays.

Programmed-Transition Override Sequence

1. Fail to Sync time delay expires.
2. If Automatic programmed-transition override is enabled, go to step 4.
3. If manual programmed-transition override is enabled, the Manual Transfer screen opens. The

operator enters the setup password and manually initiates programmed-transition transfer.

4. Standby source contacts open.
5. Off-to-preferred time delay runs and expires.
6. Preferred source contacts close.
7. Post-transfer load control time delays expire and load control contacts close.
8. The engine cooldown time delay expires and the generator set is signaled to stop (engine start contacts open).

2.4.3 Exerciser Operation, Closed Transition

Unloaded Exercise

The unloaded exercise sequence is the same as for standard transition. See Section 2.2.2.

Loaded Exercise Sequence Starts

1. Exercise timer begins.
2. Engine start time delay runs and expires.
3. The generator is signaled to start (engine start contacts close).
4. The generator starts and the standby source becomes available.
5. Load control contacts open.
6. Check/wait for source synchronization.

Note: If the sources do not synchronize before the Fail to Sync time delay expires, the programmed-transition override function operates. See Section 2.4.2.

7. When sources are synchronized, emergency source contacts close.
8. Normal source contacts open within 100 milliseconds.

Note: If the normal contacts do not open, the emergency contacts will be signaled to open and a Fail to Transfer fault will be activated.

Loaded Exercise Sequence Ends

1. Pre-transfer load control sequences run.
2. Load control contacts open.
3. Check/wait for source synchronization.

Note: If the sources do not synchronize before the Fail to Sync time delay expires, the programmed-transition override function operates. See Section 2.4.2.

4. When sources are synchronized, preferred source contacts close.
5. Standby source contacts open within 100 milliseconds.

Note: If the standby source contacts do not open within 100 ms, the extended transfer time relay trips the standby source breaker.

6. Post-transfer load control sequences and engine cooldown time delay expire.
7. Load control contacts close as programmed through the Load Add settings.
8. The generator is signaled to stop (engine start contacts open).

2.4.4 Test Sequence, Closed Transition

Unloaded Test Sequence

The unloaded test sequence is the same as for standard transition. See Section 2.2.3.

Loaded Test Sequence is Initiated

1. Engine start time delay runs and expires.
2. The generator is signaled to start (engine start contacts close).
3. The generator starts and the standby source becomes available.
4. Load control contacts open.
5. Check/wait for source synchronization.

Note: If the sources do not synchronize before the Fail to Sync time delay expires, the programmed-transition override function operates. See Section 2.4.2.

6. When sources are synchronized, emergency source contacts close.

7. Normal source contacts open within 100 milliseconds.

Note: If the normal contacts do not open, the emergency contacts will be signaled to open and a Fail to Transfer fault will be activated.

Loaded Test Sequence is Ended

1. Standby-to-preferred and pre-transfer load control time delays expire.
2. Load control contacts open according to the Load Disconnect time delay settings.
3. Check/wait for source synchronization.

Note: If the sources do not synchronize before the Fail to Sync time delay expires, the programmed-transition override function operates. See Section 2.4.2.

4. When sources are synchronized, preferred source contacts close.
5. Standby source contacts open within 100 milliseconds.

Note: If the standby source contacts do not open within 100 ms, the extended transfer time relay trips the standby source breaker.

6. Post-transfer load control sequences and engine cooldown time delay expire.
7. Load control contacts close as programmed through the Load Add settings.
8. The generator is signaled to stop (engine start contacts open).

2.4.5 Extended Transfer Time Relay

The extended transfer time relay is provided on closed-transition transfer switches. The relay is provided to prevent paralleling the standby and utility sources for longer than the acceptable time if the closed-transition transfer time exceeds 100 ms.

The relay operation time is adjustable between 100 ms and 10 seconds. The recommended setting is 1% = 0.1 seconds (100 ms). If it is necessary to set the relay to a longer time, ensure that the time setting is in accordance with applicable codes. See the transfer switch installation manual for instructions to change the time setting.

The relay activates only if the closed-transition transfer time exceeds the set time. A *Fail to Open Source1 (or Source2)* fault message will display on the ATS controller. Identify and correct the cause of the source disconnect problem before resetting the fault.

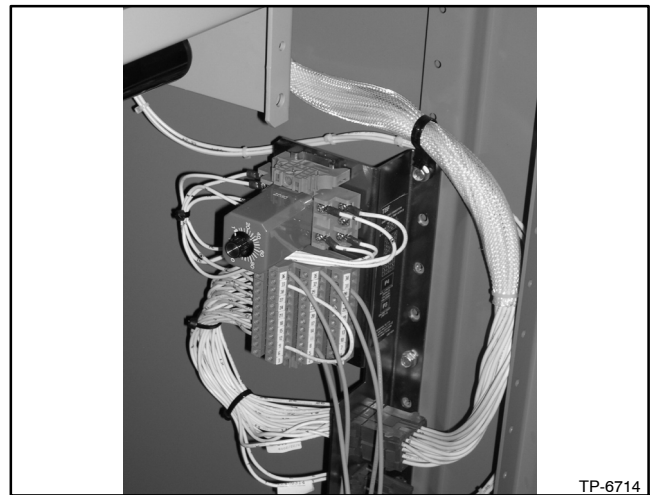

Figure 2-1 Extended Transfer Time Relay

3.1 Introduction

This section illustrates the view screens. Use the view screens to check system settings, event history, and maintenance records. No password is required to navigate through the view screens.

For detailed instructions for using the password-protected setup and test screens, see Section 4.

Some parameters will appear only under certain conditions. For example:

- The Daylight Saving Time settings are displayed only if DST is enabled.
- Phase rotation and in-phase monitoring are displayed only for three-phase systems.
- Some parameters and time delays appear only for programmed-transition models.

3.2 Main Screen

The main screen appears at system startup. See Figure 3-1.

Press the View button to navigate to the View screens shown in the following sections.

The display returns to the main screen after 10 minutes of no activity (no buttons pressed). See Section 1.6 for instructions to view system status from the main screen.

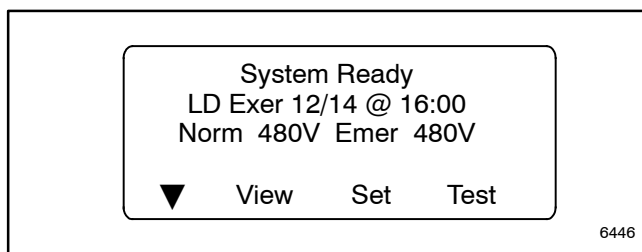
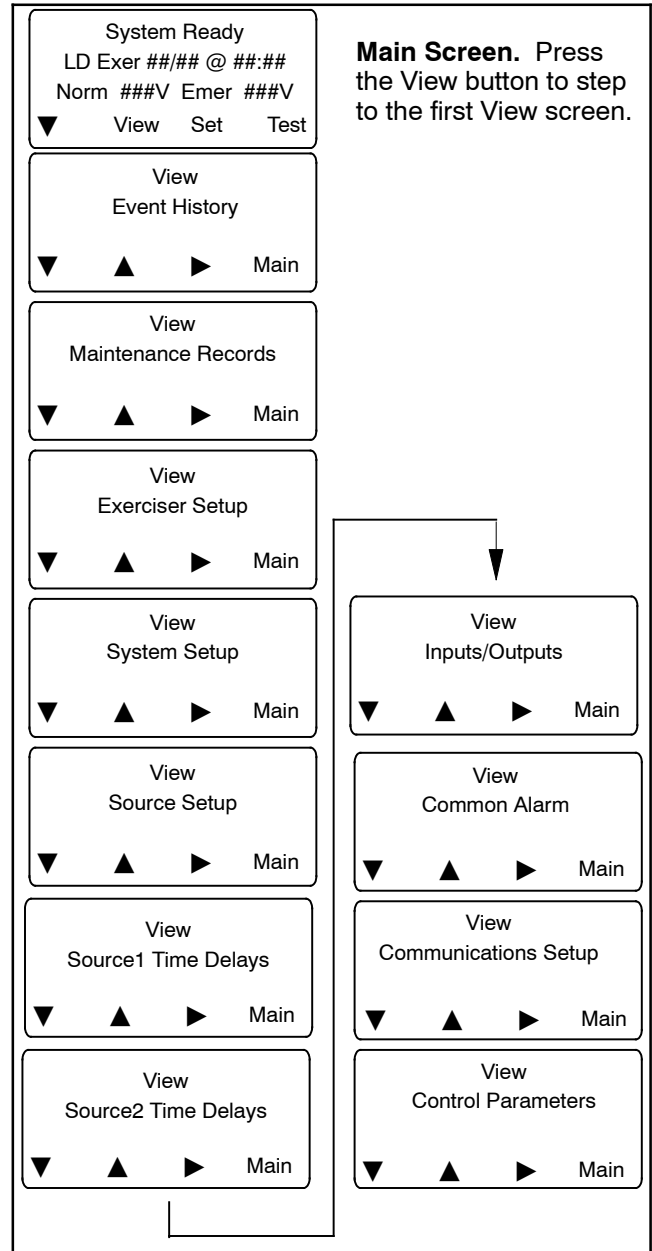

Figure 3-1 Main Screen

3.3 View Screens

From the main screen, press the View button to step to the first view screen, View Event History.

In the View screens, press the down arrow (▼) button to step to the next view screen. Press the right arrow (▶) button to view details.



3.4 View Event History

The Event History screens show recent transfer switch events. Examples of events recorded in the event history are shown in Figure 3-2. Events are time- and date-stamped. Check the event history for recent transfer switch operation, faults, or changes to settings. The event history is especially useful for transfer switch troubleshooting.

<div style="border: 1px solid black; padding: 5px; text-align: center;"> <p>View Event History</p> <p>▼ ▲ ▶ Main</p> </div> <p>Press the right arrow (▶) button to view events in the event history log.</p>	<div style="border: 1px solid black; padding: 5px; text-align: center;"> <p>Event Description</p> <p>ON/OFF MM/DD/YY HH:MM</p> <p>Additional Info</p> <p>▼ Back</p> </div> <p>Press the down arrow (▼) button to step to the next event in the log.</p>
--	---

Event Descriptions	
End Time Delay Btn Test Btn Exercise Btn Lamp Test Service Req'd Reset Maint DIP Switch Pwd DIP Switch Manual Option Switch New Module Contactor in Off Contactor in Src N Contactor in Src E Low Battery Exerciser Active Fail to Acquire Pref Fail to Acquire Stby Fail to Sync Fail to Transfer I/O Module Lost Comm Aux Switch Fault Aux Switch Open Rem End Time Delay Forced Trans to Off Peak Shave Mode Inhibit Transfer Remote Test	Low Battery Voltage Remote Common Alarm Over Frequency Under Frequency Phase Loss Phase Rotation Error Over Voltage L1- L2 Over Voltage L2- L3 Over Voltage L3- L1 Under Voltage L1- L2 Under Voltage L2- L3 Under Voltage L3- L1 Voltage Imbalance Save History To File Auto Loaded Test End Test Loaded Changed Pref Source Changed Reload Dflt Params MODBUS Peak Shave MODBUS Forced to OFF MODBUS System Test Battery Control Out Minimum Values Maximum Values Breaker Trip

Figure 3-2 Examples of Event Descriptions

3.5 View Maintenance Records

<div style="border: 1px solid black; padding: 5px; text-align: center;"> <p>View Maintenance Records</p> <p>▼ ▲ ▶ Main</p> </div> <p>Press the right arrow (▶) button to view maintenance items.</p>	<div style="border: 1px solid black; padding: 5px; text-align: center;"> <p>View Maintenance Maintenance Item #####</p> <p>▼ ▲ Back</p> </div> <p>Press the down arrow (▼) button to step to the next maintenance item.</p>
--	---

Maintenance Items	
Total Min not in Pref Reset Min Not Pref Total Min in Standby Reset Min in Standby Total Min Operation Reset Min Operation Total Transfers Reset Transfers Total Fail Transfer Reset Fail Transfer Total Loss Pref Tran Reset Loss Pref Tran	Transfer Time N>E Transfer Time E>N Dual Src Conn Time S1 to Open Time S1 to Close Time S2 to Open Time S2 to Close Time System Start Date Last Maint Date Last Loss Date/Time Last Loss Duration

3.6 View Exerciser Setup

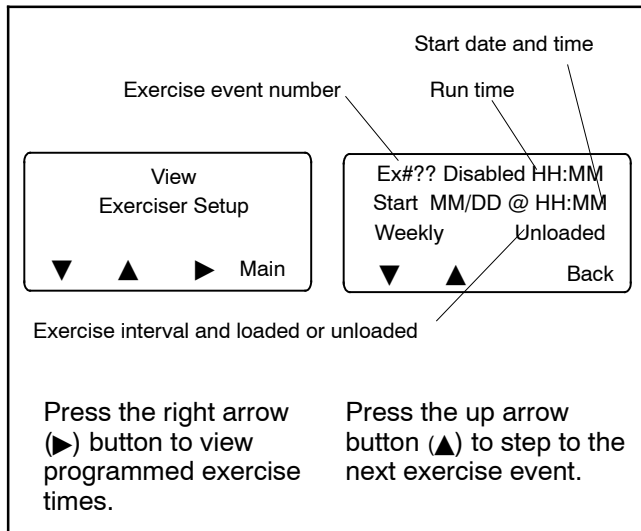

3.7 View System Setup

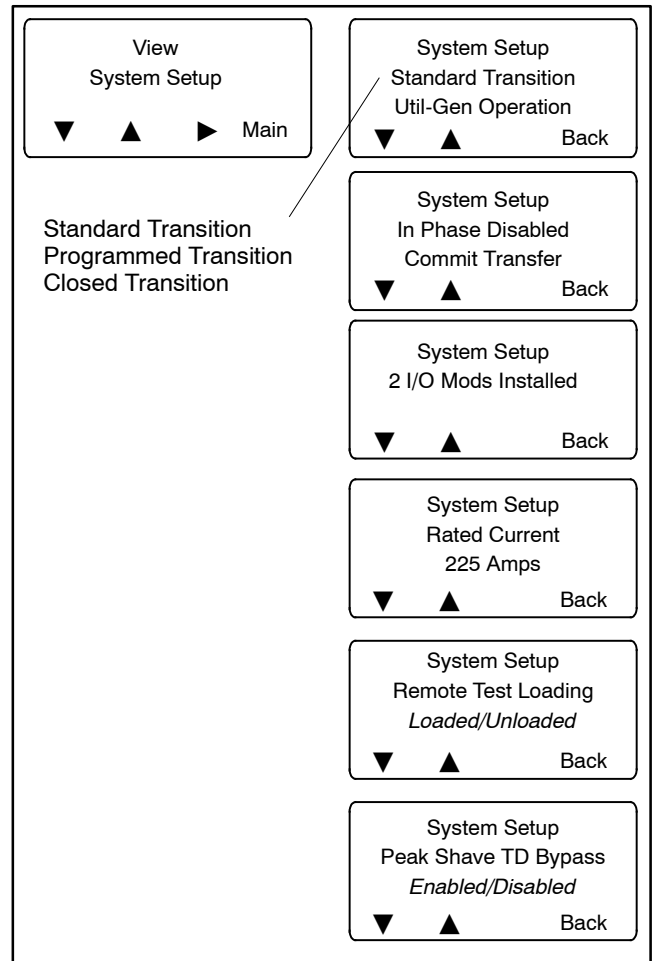

3.8 View Source Setup

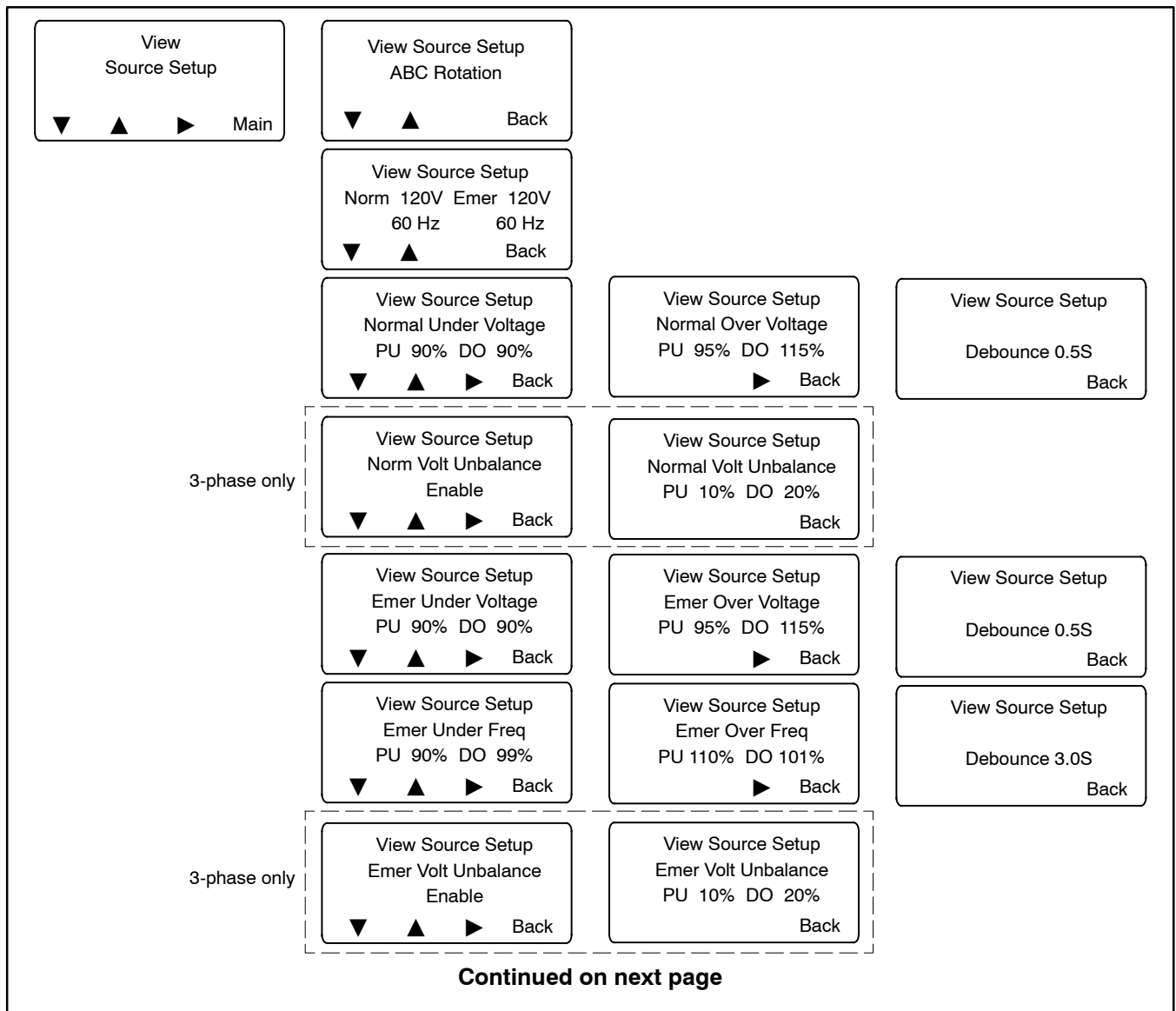

View Source Setup, Continued

Continued from previous page

Standard Transition Only

View Source Setup
In Phase Monitor

▼ ▲ ► Back

View Source Setup
In Phase Monitor
Enabled/Disabled

► Back

View Source Setup
In Phase Monitor
Angle XX Degrees

Back

View Source Setup
In Phase Xfer Fail

▼ ▲ ► Back

View Source Setup
In Phase Xfer Fail
Enabled/Disabled

► Back

View Source Setup
in Phase Xfer Fail
##:##

Back

Closed Transition Only

View Source Setup
Synchronization
Voltage Differential

▼ ▲ ► Back

View Source Setup
Voltage Differential
Percent

Back

View Source Setup
Synchronization
Freq Differential

▼ ▲ ► Back

View Source Setup
Freq Differential
0.# Hz

Back

View Source Setup
Synchronization
Angle Differential

▼ ▲ ► Back

View Source Setup
Angle Differential
XX Degrees

Back

View Source Setup
Fail to Sync

▼ ▲ ► Back

View Source Setup
Fail to Sync
Enabled/Disabled

► Back

View Source Setup
Fail to Sync
##:##

Back

3.9 View Time Delays, Source 1

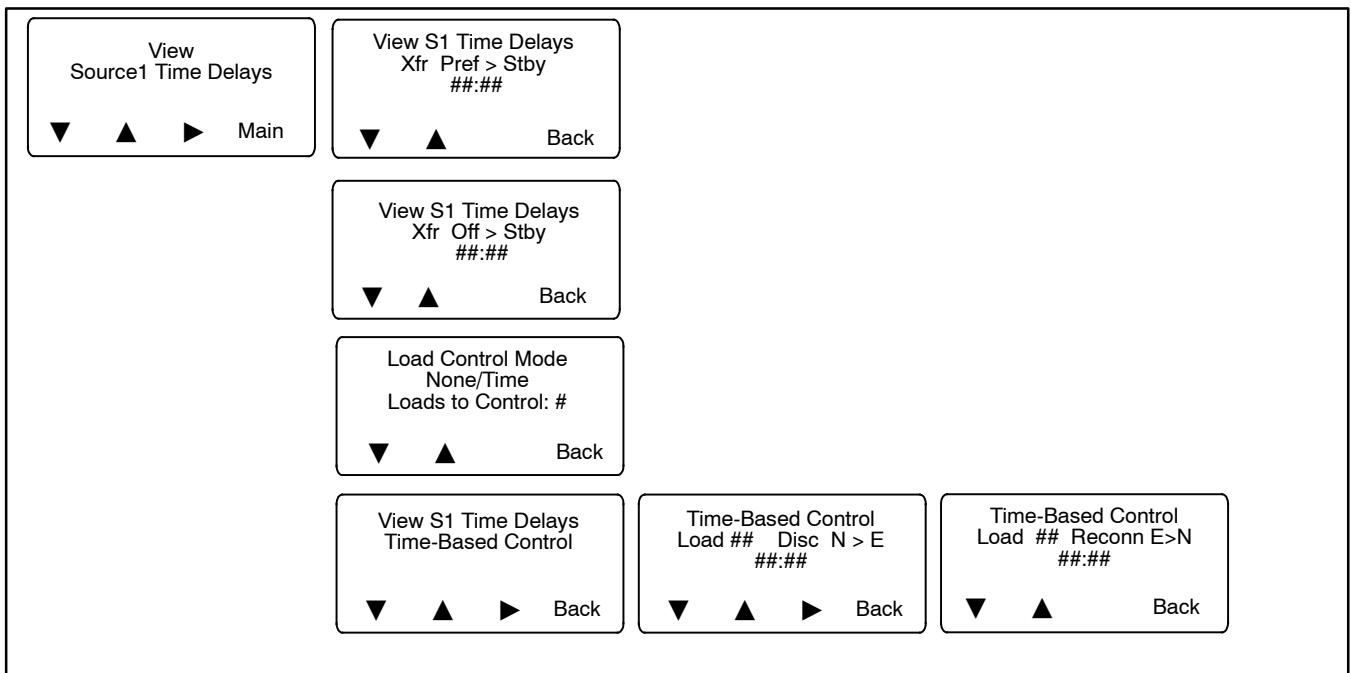

3.10 View Time Delays, Source 2

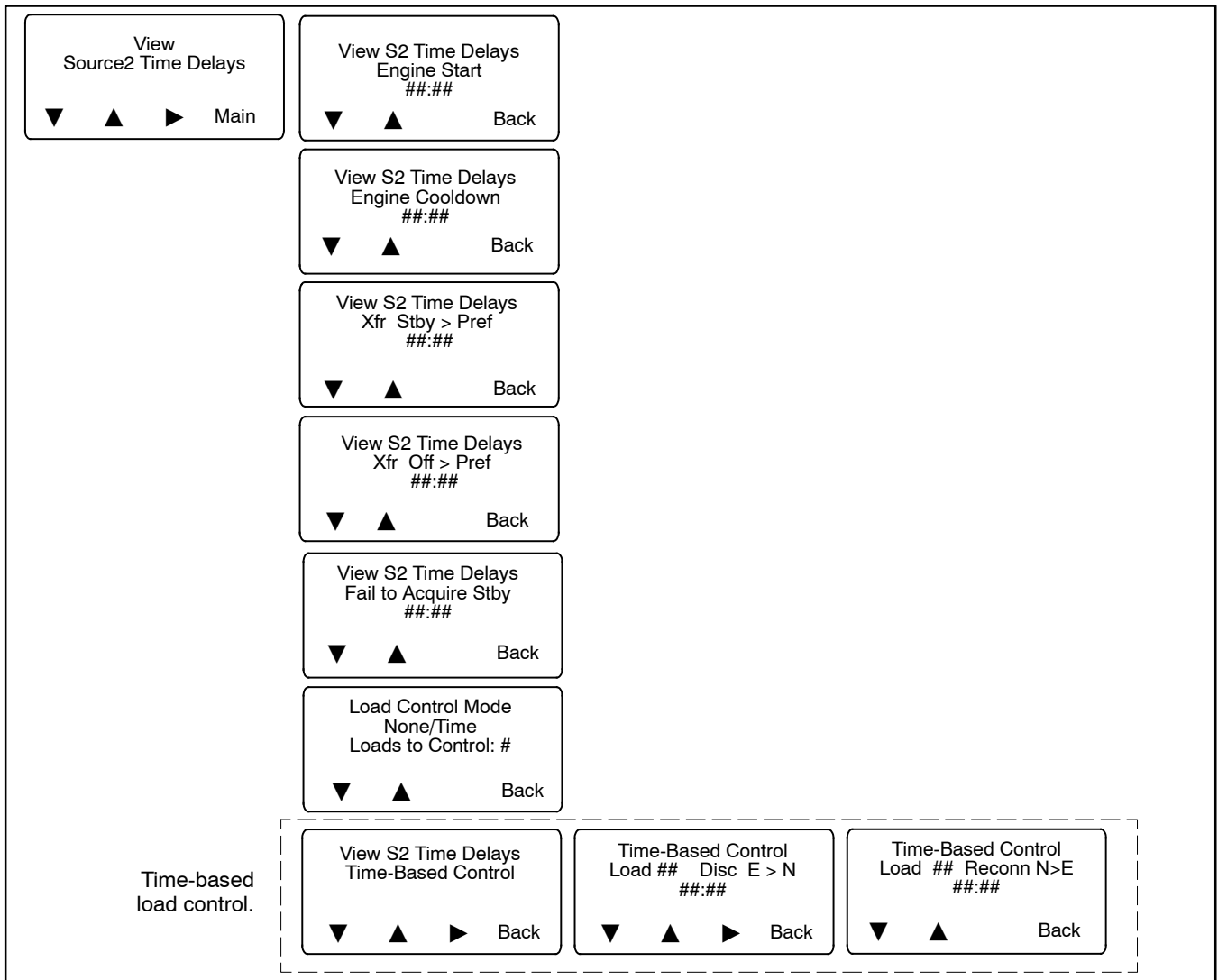

3.11 View Inputs/Outputs

<p>View Inputs/Outputs</p> <p>▼ ▲ ► Main</p>	<p>View Main Board I/O</p> <p>▼ ▲ ► Back</p>	<p>Main Board I/O Input ## <i>Function Description</i></p> <p>▼ ▲ Back</p>
		<p>Main Board I/O Output ## <i>Function Description</i></p> <p>▼ ▲ Back</p>
	<p>View Auxiliary I/O</p> <p>▼ ▲ ► Back</p>	<p>Module #1 Type ### Addr 1 Status: OK</p> <p>▼ ▲ ► Back</p>
		<p>Module #1 Input ## <i>Function Description</i></p> <p>▼ ▲ Back</p>
		<p>Module #1 Output ## <i>Function Description</i></p> <p>▼ ▲ Back</p>

See Section 4.7 for input and output function descriptions.

3.12 View Common Alarms

<p>View Common Alarm</p> <p>▼ ▲ ► Main</p>	<p>View Common Alarms Alarms Group #</p> <p>▼ ▲ ► Main</p>	<p>View Common Alarms <i>Alarm Description</i> Audible:N Common:Y</p> <p>▼ ▲ Back</p>
--	--	---

3.13 View Communications Setup

Ethernet communication requires the Ethernet communication accessory board.

View Communications Setup ▼ ▲ ▶ Main	View Comm Setup MODBUS Server TCP <i>Enabled/Disabled</i> ▼ ▲ Back
	View Comm Setup MODBUS Server Port 0 <i>Enabled/Disabled</i> ▼ ▲ Back
	View Comm Setup MODBUS Addr Port 0 #### ▼ ▲ Back
Baud Rates: 9600 19200 57600	View Comm Setup Baud Rate Port 0 ##### ▼ ▲ Back
	View Comm Setup MODBUS TCP Unit ID ##### ▼ ▲ Back
	View Comm Setup IP Address ###.###.###.### ▼ ▲ Back
	View Comm Setup Subnet Mask ###.###.###.### ▼ ▲ Back
	View Comm Setup MAC Address ##-##-##-##-##-## ▼ ▲ Back
	View Comm Setup Default Gateway ##-##-##-##-##-## ▼ ▲ Back
	View Comm Setup DHCP Status <i>Enabled/Disabled</i> ▼ ▲ Back

3.14 View Control Parameters

The site designation, load description, branch description, and location are designed to identify the transfer switch. Use a personal computer and Kohler® SiteTech™ software to enter descriptions that uniquely identify the transfer switch. In SiteTech, these items appear under ATS Information.

Kohler SiteTech software is available to Kohler authorized distributors and dealers.

View Control Parameters ▼ ▲ ▶ Main	Control Parameters Application Ver: ▼ ▲ Back
	Control Parameters ATS Serial Number: ##### ▼ ▲ Back
	Control Parameters Controller Ser. #: ##### ▼ ▲ Back
	Control Parameters Contactor Serial #: ##### ▼ ▲ Back
	Control Parameters Site Designation: <i>NOT SET</i> ▼ ▲ Back
	Control Parameters Load Description: <i>NOT SET</i> ▼ ▲ Back
	Control Parameters Branch Description: <i>NOT SET</i> ▼ ▲ Back
	Control Parameters Location: <i>NOT SET</i> ▼ ▲ Back

Note: Serial numbers are factory-set. Use SiteTech™ software to set the other parameters to identify the transfer switch.

Notes

4.1 Introduction

The Decison-Maker® MPAC 1200 controller is factory-set for your transfer switch model. Some settings may need to be changed at installation or during service. This section lists factory default settings and includes instructions to change parameter settings using the setup menus.

Use the Setup menus to change the controller pickup and dropout settings, inputs, outputs, time delays, and options, if necessary.

Settings can also be assigned using a personal computer with Kohler® SiteTech™ software or over Modbus. SiteTech™ software is available to authorized Kohler distributors. See TP-6701, SiteTech Software Operation Manual, for instructions to change settings using SiteTech software. See TP-6113, Modbus Protocol Manual, for Modbus register maps.

4.2 Setup Menus

From the main operation window, press the Set button to enter the setup menus.

The setup password is required. The default password is 0000. Changing the password is recommended. See Section 4.11 for instructions to change the password.

After entering the system password, use the black arrow keys to step through the setup menus as shown in Figure 4-1.

Timeout. After 10 minutes of no activity (no buttons pressed) the controller exits the setup mode and returns to the main menu.

The following sections discuss the setup menus in the order of appearance on the controller.

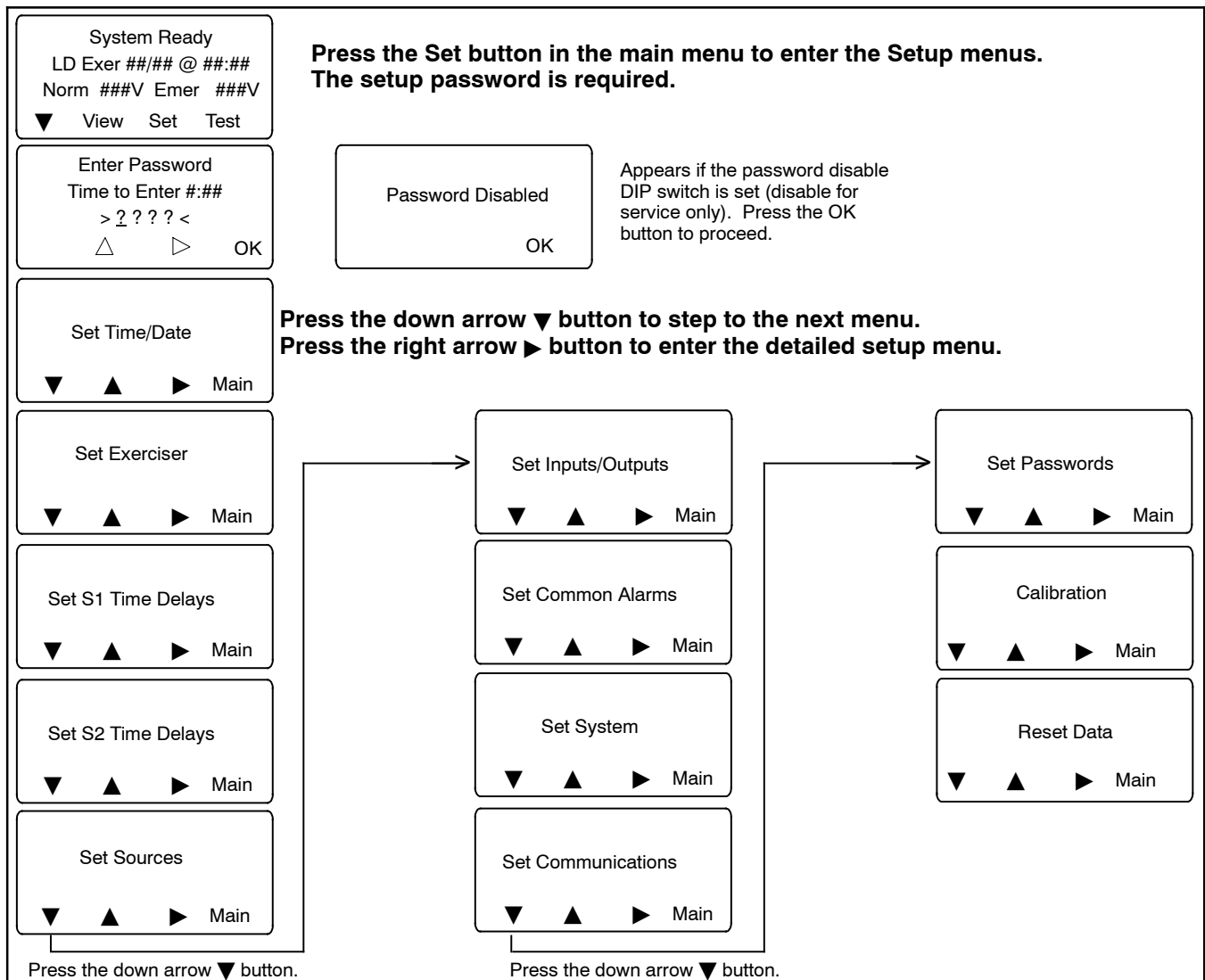

Figure 4-1 Main Setup Menu

4.3 Time/Date

Note: Set the current time and date after transfer switch installation or after an extended period of no power.

Set the current time and date. The time and date are used by the exercise function and event history functions.

The Time/Date setup menu includes the option to enable automatic Daylight Saving Time and set the start and stop date. See Figure 4-2.

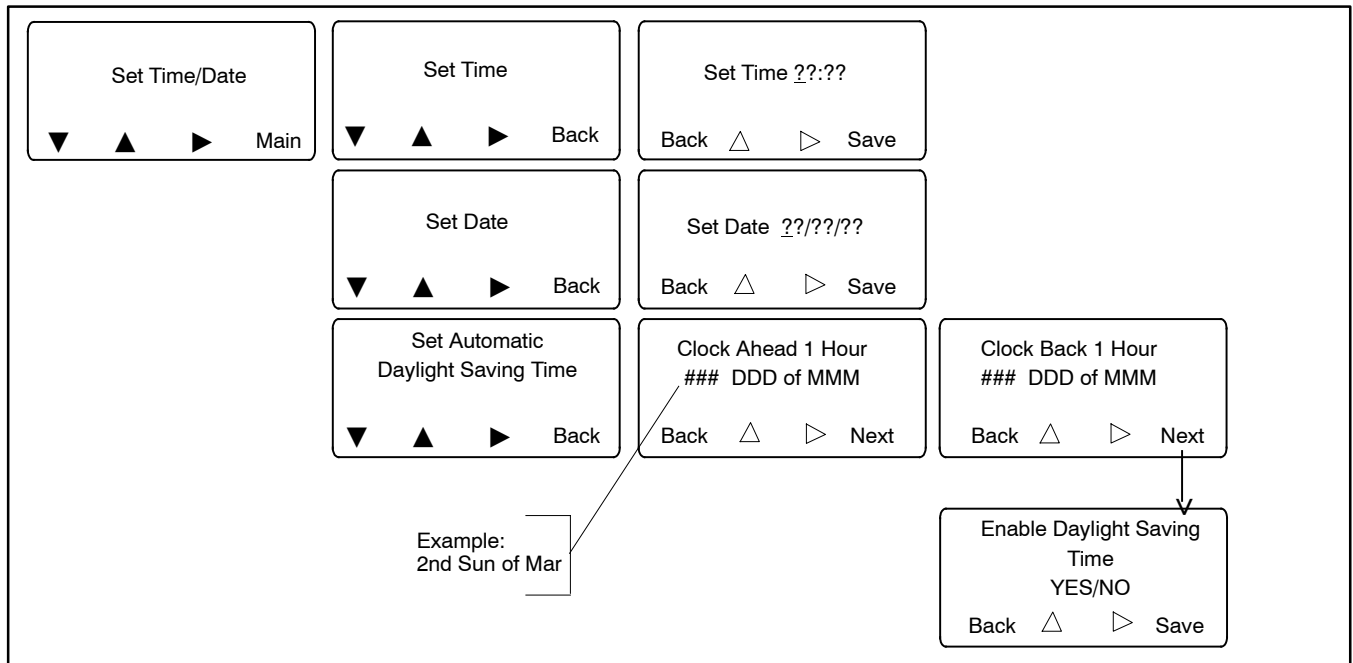

Figure 4-2 Setting the Time and Date

4.4 Exerciser

The exerciser uses a calendar-based scheduling system. Up to 21 different exercise events can be scheduled, each with different settings. Exerciser settings include the start date, start time, run duration, type (loaded or unloaded), interval, and repeat rate. See Figure 4-3.

An exercise event can be temporarily disabled to prevent its execution and then re-enabled later using the enable/disable setting.

The next scheduled exercise time and date are indicated on the main menu. (See Figure 1-7.)

See Figure 4-4 for the Set Exerciser menu.

The exercise function occurs on the standby source.

Exerciser Parameter	Description
Event Number	Each scheduled exercise is called an event. Up to 21 different exercise events can be set, each with different settings for the parameters shown in this table.
Enable/Disable	Enable the event to allow it to run as scheduled. Disable an event to prevent it from running. The event remains on the calendar so that it can be enabled again at a later time. This allows you to temporarily prevent a scheduled exercise event from running, and then enable it again later without having to re-enter all the settings.
Loaded/Unloaded	A loaded exercise starts the generator set and transfers the electrical load from the normal source to the standby generator set. An unloaded exercise will start and run the generator set without transferring the load.
Interval	Daily, weekly, monthly, or day/month. This setting works with the repeat rate to set the time interval between exercise runs. The day/month selection allows you to set the exerciser to run on the same day every month. For example, the exerciser can be set to run the first Sunday of every month. Use caution with the day/month selection. For example, selecting day/month on the 5th Friday of the month will cause the exerciser to run only during months that have five Fridays.
Repeat Rate	The repeat rate works with the interval to set the time interval between exercise runs. For example, if Day is selected as the interval, and 5 is selected as the repeat rate, then the exercise will repeat every 5 days. Select a number from 1 to 12.
Duration	Enter the exercise run duration in hours:minutes. For example, a run time of 00:30 will run the generator set for 30 minutes. The maximum run time is 24 hours.
Start Date	Enter the date, month/date/year, of the first exercise event. Subsequent events will be scheduled based on the interval and repeat rate.
Start Time	Enter the desired start time of the exercise run in hours:minutes. The time settings range from 00:00 to 23:59, with 00:00=midnight.

Figure 4-3 Exerciser Settings

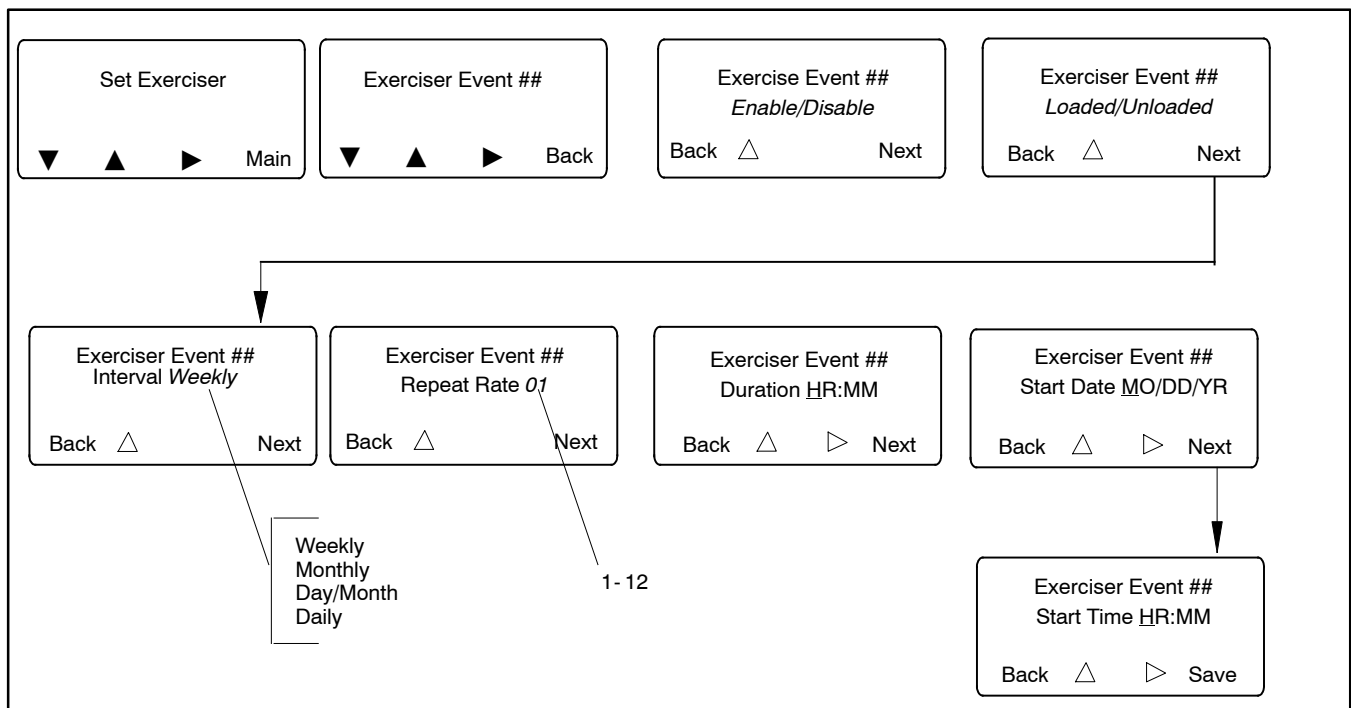

Figure 4-4 Setting the Exerciser

4.5 Time Delays

4.5.1 Time Delays

The factory settings and adjustment ranges for the time delays are shown in Figure 4-5.

The engine start time delay and transfer time delays can prevent nuisance transfers caused by brief voltage dips or surges. The engine cooldown time delay holds the engine start contacts closed for a designated time after transfer to allow the generator set to run without load before shutting down.

4.5.2 Load Control Time Delays

The pre/post-transfer load control time delays allow loads to be sequenced on and off prior to and following transfers. The pre-transfer signals are active only when both sources are available. The pre-transfer signals overlap the transfer time delays (Xfr N>E and E>N). The longer delay determines the time delay before transfer. Up to nine loads can be controlled with independent timing sequences for pre- and post-transfer delays in either direction of transfer.

Proceed to Section 4.5.5, Load Control, for more information.

Time Delay Description	Description/Note	Default Time	Adjustment Range
Engine Start, Source S2	Source S2, Emergency source	3 sec	0 - 6 sec *
Engine Cooldown, Source S2	Source S2 Emergency source	5 min.	0 - 60 min
Xfr Pref>Stby	Transfer delay, preferred to standby	3 sec	
Xfr Stby>Pref	Transfer delay, standby to preferred	15 min	
Xfr Off>Stby	Time in the OFF position (Preferred to Standby for programmed transition models only)	1 sec	1 sec. - 60 min
Xfr OFF>Pref	Time in the OFF position (Standby to Preferred for programmed transition models only)	1 sec	1 sec. - 60 min
Fail to Acquire Stby	If the standby source does not reach acceptable voltage and stabilize within the allowed time, the Fail to Acquire Standby Source fault is activated.	1 min	0 - 60 min
Fail to Synch	For closed-transition models only. Found in the Set Sources menu. Operates when two sources are available. If the sources do not synchronize before the Fail to Sync time delay expires, the programmed-transition override function operates. See Section 4.9.	1 min	10 seconds - 15 min
In-Phase Xfr Fail (found in the Set Sources menu)	For in-phase monitoring: the time allowed for the two sources to come into synchronization within specified phase angle before a Fail to Sync fault is activated. See Section 4.6.	30 sec	0- 60 min
Load # Disc N>E	Disconnect load before-transfer to standby source. Used for time-based load control. See Section 4.5.5.	0 sec	
Load # Rec N>E	Reconnect load after-transfer to standby source. Used for time-based load control. See Section 4.5.5.	0 sec	
Load # Disc E>N	Disconnect load before-transfer to preferred source. Used for time-based load control. See Section 4.5.5.	0 sec	
Load # Rec E>N	Reconnect load after-transfer to preferred source. Used for time-based load control. See Section 4.5.5.	0 sec	

* The optional external battery module allows extended engine start time delays from 0- 60 min.

Figure 4-5 Time Delay Settings

4.5.4 Set S2 Time Delays

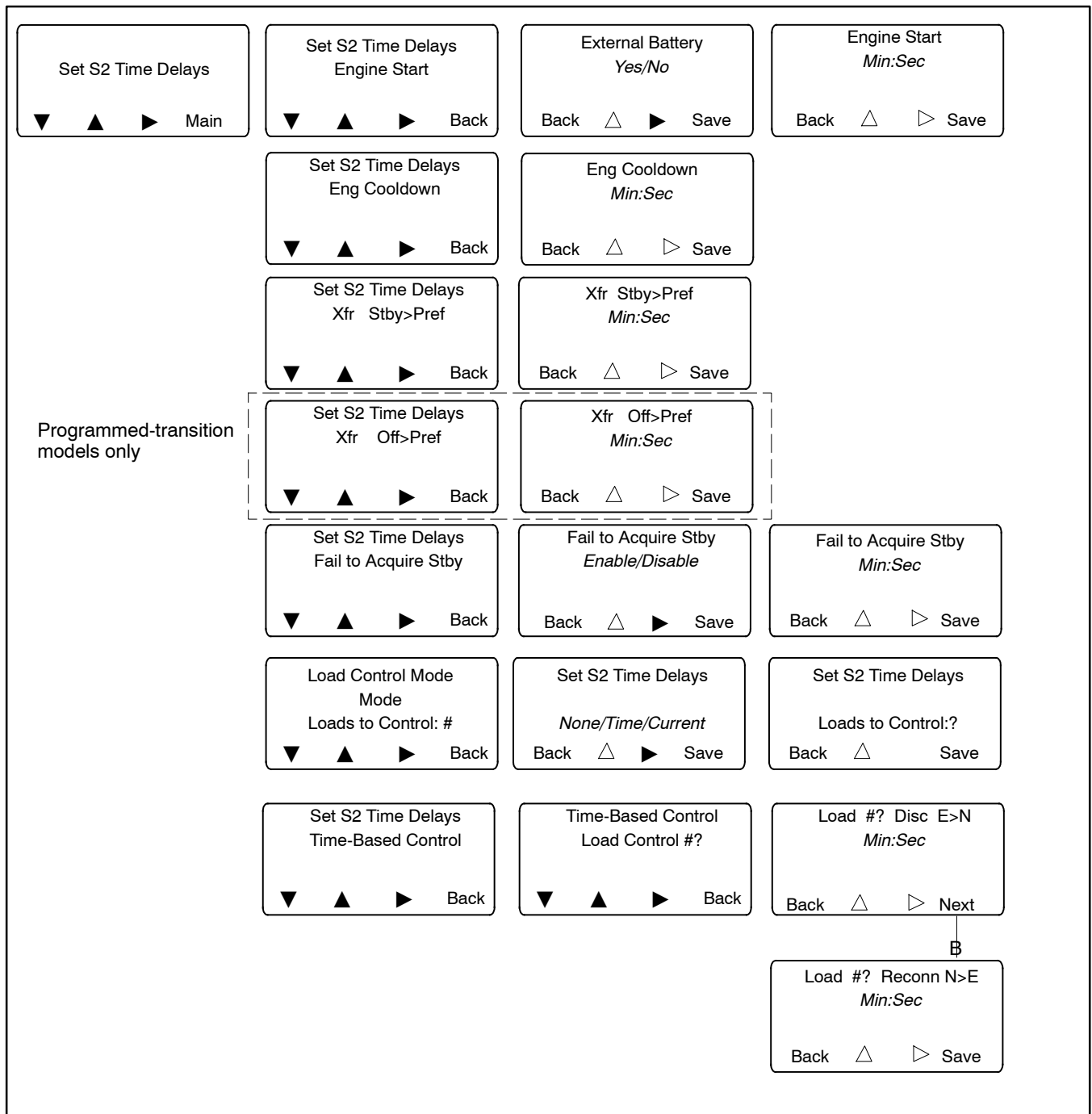

4.5.5 Time-Based Load Control

The controller allows time-based control of up to 9 separate loads. Time-based load control adds and removes selected loads according to a timed sequence before and after transfer.

When the load control function is activated, the contacts open a programmed length of time before transfer to allow controlled disconnection of selected loads. After transfer, the contacts remain open for a programmed length of time and then close to allow controlled application of selected loads. For example, large motor loads such as an air conditioner can be delayed to start after other essential loads have been transferred.

The load control function is not activated if the controller detects no available source. The pre-transfer signals are active only when both sources are available; for example, during loaded test, loaded exercise, or programmed transfers for peak shave operation when the transfer is controlled.

Note that the load control can be set up to operate during transfer to Source1 and/or Source2. Your application may require load control during transfer to one source (e.g. a generator set) but not the other source (e.g. the utility). The loads can be connected and disconnected at different times for each source.

The pre-transfer load disconnect signals overlap the preferred-to-standby and standby-to-preferred transfer

time delays. See Figure 4-6. If any of the pre-transfer load disconnect time delays are longer than the transfer time delay, the longest delay will control the time delay before transfer.

Note: The load control setup parameters are found in the Set S1 Time Delays and Set S2 Time Delays menus. See Section 4.5.3 and Section 4.5.4 for the time delay menus.

The Load # Disc N>E pre-transfer time delay disconnects loads a programmed time before transfer from Normal to Emergency. The pre-transfer delays operate during loaded test, loaded exercise, or programmed transfers for peak shave operation when the transfer is controlled.

The Load # Recon E>N post-transfer time delay reconnects loads a programmed time after transfer to Normal. The post-transfer time delay allows delayed or staggered addition of selected loads to avoid starting numerous large motors or other large loads at the same time. Staggering the loads can minimize voltage dips as large loads come online.

The Loads to Add setting is the number of loads that have been connected to load control outputs for pre-transfer disconnect and delayed reconnect. Up to 9 separate loads can be connected.

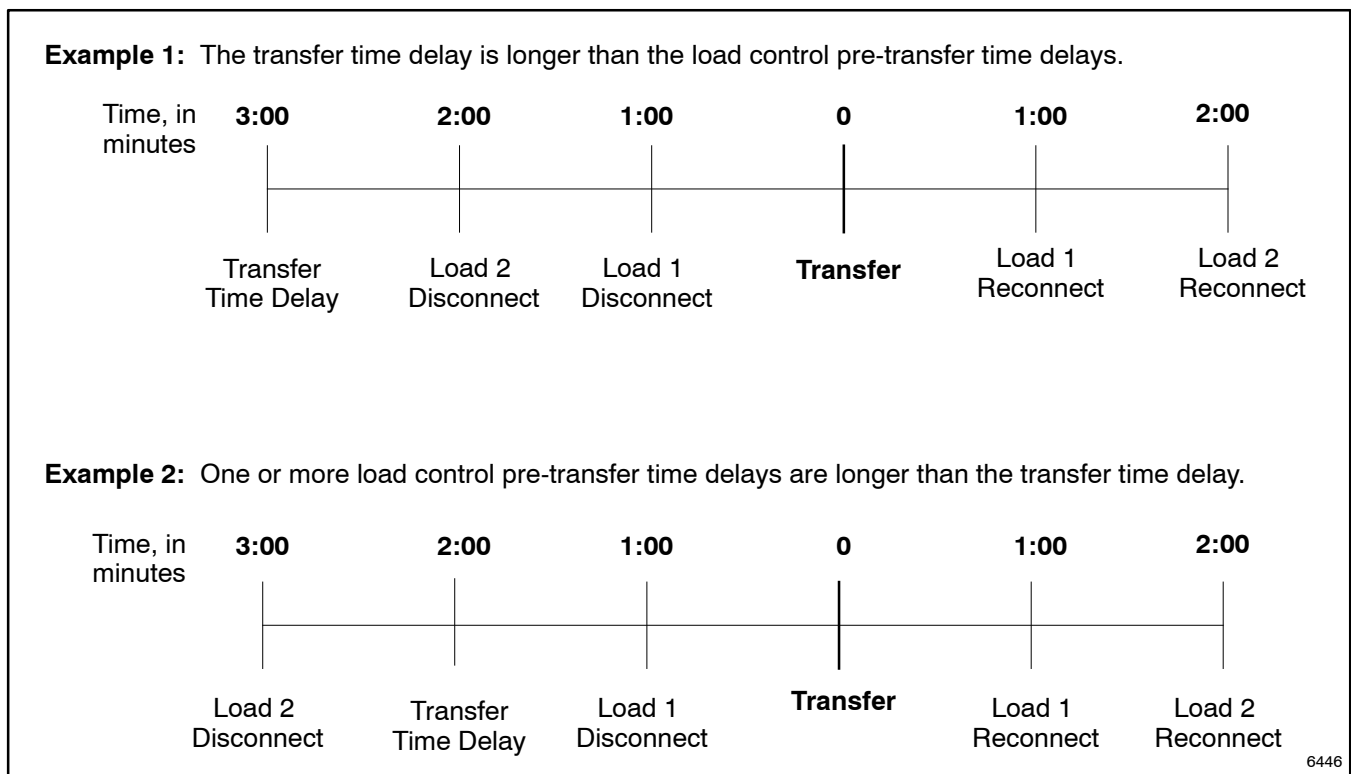

Figure 4-6 Time-Based Load Control and Transfer Time Delays

Time-Based Load Control Setup

Setting up the load control function requires the following steps.

1. Connect each selected load to an output terminal on the main logic board or one of the input/output modules. The high power module accessory is available for high voltage or high current loads.
2. Use the Set Inputs/Outputs menu to assign the connected output to one of the load control outputs 1-9. See Section 4.7.
3. Navigate to the Set S1 Time Delays or Set S2 Time Delays menu. See Section 4.5.3 and Section 4.5.4 for the time delay menus.

Note: Save the setting after each step and then use the Back and arrow buttons to navigate to the next setting as needed.

4. In the Set S1 Time Delays menu, select Time as the load control mode.
5. Enter the number of loads to control, which is equal to the number of loads connected to outputs in step 1.

6. Use the Set S1 Time Delays menu to set the following associated time delays.
 - a. Load # Disc N>E: Enter the pre-transfer time delay in Minutes: seconds, up to 60 minutes.
 - b. Load # Reconn E>N: Enter the post-transfer time delay in Minutes: seconds, up to 60 minutes.
 - c. Loads to Add: Enter the number of loads that have been connected to load control outputs, from 1 to 9.
7. If time-based load control is required for source 2, go to the Set S2 Time Delays menu and repeat steps 3 through 6 for source 2.

4.6 Set Sources

4.6.1 Phase Rotation

The Phase Rotation menu appears only if a three-phase source is selected. (See Set Number of Phases later in the Set Sources menus for the Normal and Emergency sources.)

Select ABC, BAC, or disabled. Phase rotation can be disabled for programmed-transition models or standard-transition models in applications that do not have phase-sensitive loads. Phase rotation cannot be disabled on closed-transition models.

4.6.2 In-Phase Monitor

Standard-Transition Models

The in-phase monitor can be enabled or disabled for standard-transition models. The in-phase monitor operates prior to transfer when both sources are available. Transfer is inhibited while both sources are greater than 2 cycles apart. If the connected source falls below 70% of its nominal voltage rating, the in-phase monitor terminates and allows transfer.

The synchronism window has a default value of 5° and is adjustable from 15° to 5° before synchronism only. The in-phase monitor feature can be enabled for Util-Gen and Gen-Gen modes of operation. In Util-Util mode, it is assumed that both sources are always in phase with each other, and immediate transfer occurs when in-phase monitoring is enabled.

Programmed-Transition Models

The in-phase monitor is disabled for programmed-transition models.

Closed-Transition Models

The in-phase monitor is always enabled for closed-transition models. Synchronization settings for closed-transition models include voltage differential, frequency differential, angle differential, and the Fail to Sync time delay. Transfer is inhibited when any of the differential readings between the two sources are outside the set limits. See Figure 4-7.

Parameter	Adjustment Range	Default Setting
Voltage Differential	0- 5%	5%
Frequency Differential	0- 0.3 Hz	0.1 Hz
Angle Differential	0- 10 degrees	10 degrees
Fail to Sync time delay	0- 60 min.	30 sec.

Figure 4-7 Synchronization Settings for Closed-Transition Switches

4.6.3 Preferred Source Selection

The preferred source selection function allows selection of either Source N or Source E as the preferred source.

Note: The alarm module accessory must be installed for this function to operate. See Section 7.2.3.

The transfer switch seeks and transfers to the preferred source whenever it is available. Source N is always the source connected to the Normal side of the transfer switch, and Source E is always connected to the Emergency side. Generator engine start relays are assigned to the source (Source N or Source E). The engine start relays do not change when the preferred source selection changes. This prevents the need to change the wiring of the engine start relay(s) when the preferred source changes.

Source Types. The transfer switch is factory-set for the utility-generator set source types. This type uses one generator set, which is connected to the Emergency side of the contactor (Source E), and one engine start relay. The engine start contact is assigned to the connected generator set and does not change assignment when the preferred source selection is changed. In this mode, if the preferred source selection is set to Source E, the system operates the generator set indefinitely, transferring to utility power only if the generator set fails.

Time Delays and Source Parameters. Engine start relays and time delays, source voltage and frequency trip points, and load shed time delays are assigned to the source (N or E). They do not change assignment when the preferred source selection is changed.

Note: Source N is always connected to the Normal side of the transfer switch, and Source E is always connected to the Emergency side.

Other time delays are assigned to the source function (preferred or standby). System parameters that are assigned to the function automatically change source when the preferred source selection changes.

Figure 4-8 shows which parameters are assigned to the source and which are assigned to the function. The last two columns of the table show the effect of the preferred source selection on each parameter or time delay.

Item	Assignment	Preferred Source Selection	
		Normal	Emergency
Source N generator engine start relay	Source	N	N
Source E generator engine start relay	Source	E	E
Source N engine start time delay	Source	N	N
Source E engine start time delay	Source	E	E
Source N engine cooldown time delay	Source	N	N
Source E engine cooldown time delay	Source	E	E
Source N voltage and frequency trip points	Source	N	N
Source E voltage and frequency trip points	Source	E	E
In-phase monitor sync	Source	E	E
Pre-transfer to source N	Source	N	N
Pre-transfer to source E	Source	E	E
Post-transfer to source N	Source	N	N
Post-transfer to source E	Source	E	E
Preferred-to-standby time delay	Function	N to E	E to N
Standby-to-preferred time delay	Function	E to N	N to E
Failure to acquire standby source	Function	E	N
Off-to-standby time delay (programmed-transition only)	Function	Off to E	Off to N
Off-to-preferred time delay (programmed-transition only)	Function	Off to N	Off to E
Note: Source N is connected to the Normal side of the transfer switch, and Source E is connected to the Emergency side.			

Figure 4-8 Preferred Source Selection Effect on System Parameters and Time Delays

4.6.4 System Voltage and Frequency

For each source, set the number of phases, nominal voltage, and nominal frequency (50 or 60 Hz). Then proceed to set the pickup and dropout settings.

4.6.5 Voltage and Frequency Pickup and Dropout Settings

The controller senses the voltage on both sources with an accuracy of $\pm 0.5\%$. A source is considered

available when its voltage and frequency are within the range of dropout settings. The debounce time prevents nuisance transfers caused by brief voltage spikes and dips. If the voltage or frequency of the active source is outside the acceptable range for a length of time longer than the debounce time, the system attempts to transfer the load to the alternate source.

See Figure 4-9 for default settings and adjustment ranges.

Description	Settings	Default Setting	Adjustment Range
Normal source voltage	Under voltage dropout	90%	75% to 98% of Pickup
	Under voltage pickup	90%	85% to 100% of Nominal
	Over voltage dropout	115% (110% for 600 V systems)	106% to 135% of Nominal (maximum 690 Volts)
	Over voltage pickup	95%	95 to 100% of Dropout
	Unbalance enable	Enable	Enable or disabled
	Unbalance drop out	20%	5% to 20%
	Unbalance pick up	10%	3% to 18%
	Debounce time	0.5 seconds	0.1 to 9.9 seconds
Emergency source voltage	Under voltage dropout	90%	75% to 98% of Pickup
	Under voltage pickup	90%	85% to 100% of Nominal
	Over voltage dropout	115% (110% for 600 V systems)	106% to 135% of Nominal (Except 600 V Apps)
	Over voltage pickup	95%	95 to 100% of Dropout
	Unbalance enable	Enable	Enable or disabled
	Unbalance drop out	20%	5 to 20%
	Unbalance pick up	10%	3 to 18%
	Debounce time	0.5 seconds	0.1 to 9.9 seconds
Emergency source frequency	Under frequency dropout	99%	95% to 99% of Pickup
	Under frequency pickup	90%	80% to 95% of Nominal
	Over frequency dropout	101%	101% to 115% of Pickup
	Over frequency pickup	110%	105% to 120% of Nominal
	Debounce time	3 seconds	0.1 to 15 seconds

Figure 4-9 Pickup and Dropout Settings

4.6.6 Set Sources

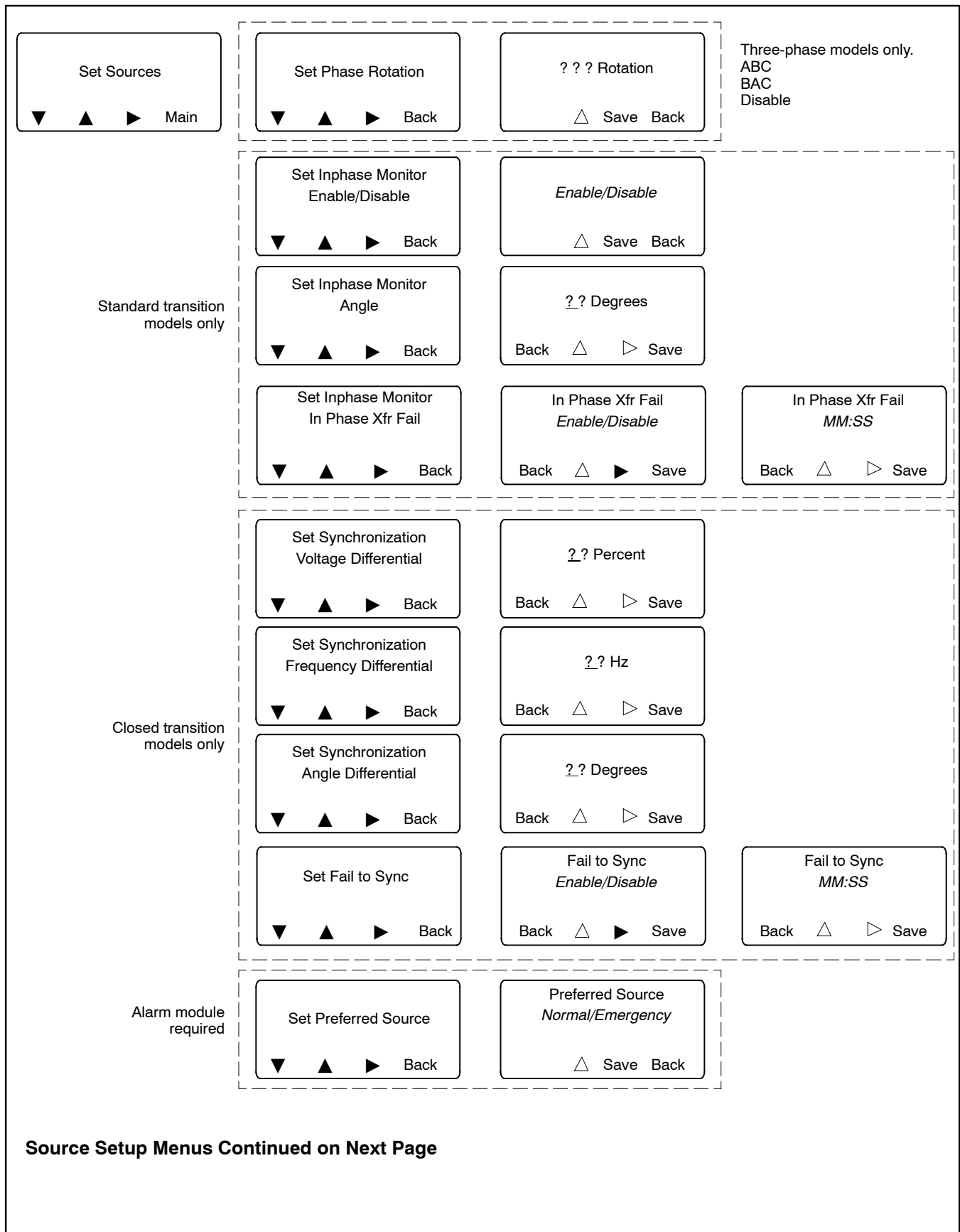

Source Setup Menus Continued from Previous Page:

Set Normal Source
Emergency
▼ ▲ ► Back

Note: The same menus are available for the Emergency source.

Normal Source
Set Number of Phases
▼ ▲ ► Back

Single/Three Phase
▲ Save Back

Normal Source
Set Voltage
▼ ▲ ► Back

Set Voltage
?? VAC
Back ▲ ► Save

Normal Source
Set Frequency
▼ ▲ ► Back

Set Frequency
?? Hz
Back ▲ ► Save

Normal Source
Set Under Voltage
Pickup
▼ ▲ ► Back

Pickup
??? % of Nominal
85- 100%
▽ ▲ Save Back

Normal Source
Set Under Voltage
Dropout
▼ ▲ ► Back

Dropout
??? % of Pickup
75- 98%
▽ ▲ Save Back

Normal Source
Set Over Voltage
Pickup
▼ ▲ ► Back

Pickup
??? % of Dropout
95- 100%
▽ ▲ Save Back

Normal Source
Set Over Voltage
Dropout
▼ ▲ ► Back

Dropout
??? % of Nominal
106- 135%
▽ ▲ Save Back

Normal Source
Set Voltage Debounce
▼ ▲ ► Back

Debounce Time
?.? Seconds
0.1 - 9.9 Seconds
▽ ▲ Save Back

Normal Source
Voltage Unbalance
Enable/Disable
▼ ▲ ► Back

Voltage Unbalance
Enable/Disable
▲ Save Back

Three-phase only

Normal Source
Voltage Unbalance
Pickup
▼ ▲ ► Back

Pickup
??%
3- 18%
▽ ▲ Save Back

Normal Source
Voltage Unbalance
Dropout
▼ ▲ ► Back

Dropout
??%
5- 20%
▽ ▲ Save Back

Continue to next page for additional menus for Emergency source only

Additional Source Setup Menus for the Emergency Source Only:

Set Emergency Source
▼ ▲ ► Back

continued from previous page

B

Emergency Source
Set Under Frequency
Pickup
▼ ▲ ► Back

Emergency Source
Set Under Frequency
Dropout
▼ ▲ ► Back

Emergency Source
Set Over Frequency
Pickup
▼ ▲ ► Back

Emergency Source
Set Over Frequency
Dropout
▼ ▲ ► Back

Emergency Source
Set Freq Debounce
▼ ▲ ► Back

Pickup
??? % of Nominal
80-95%
▽ ▲ Save Back

Dropout
??? % of Pickup
95-99%
▽ ▲ Save Back

Pickup
??? % of Nominal
105-120%
▽ ▲ Save Back

Dropout
??? % of Pickup
101-115% Nominal
▽ ▲ Save Back

Debounce Time
?.? Seconds
0.1 - 15.0 Seconds
▽ ▲ Save Back

4.7 Inputs and Outputs

Inputs and outputs are unassigned (except as noted in Figure 4-11) until the installer or operator assigns a function to the I/O.

The programmable inputs and outputs can be assigned to the functions shown in Figure 4-12 and Figure 4-13. Programmable inputs and outputs on the controller and input/output (I/O) modules can be assigned in several ways:

- Using the controller's keypad and display; see Figure 4-10.
- Using a PC with Kohler® SiteTech™ software; see TP-6701, SiteTech Software Operation Manual, for instructions.
- Over Modbus; see TP-6113, Modbus Protocol Manual, for Modbus registers.

Each programmable input and output requires a connection to the transfer switch. Do not change the programmable input/output assignments without

verifying the transfer switch input and output connections.

4.7.1 Controller Inputs and Outputs

There are two programmable inputs and two programmable outputs on the controller. Additional inputs and outputs are available through the installation of optional input/output modules.

See the Installation Section for connection information for main logic board inputs and outputs.

4.7.2 Input/Output Modules

Input/output (I/O) modules are optional accessories. The standard I/O Module has two inputs and six outputs. The high-power I/O module has two inputs and three outputs. The I/O modules specifications are shown in Section 7.2.1.

See Section 7.2.1 for I/O module connection information.

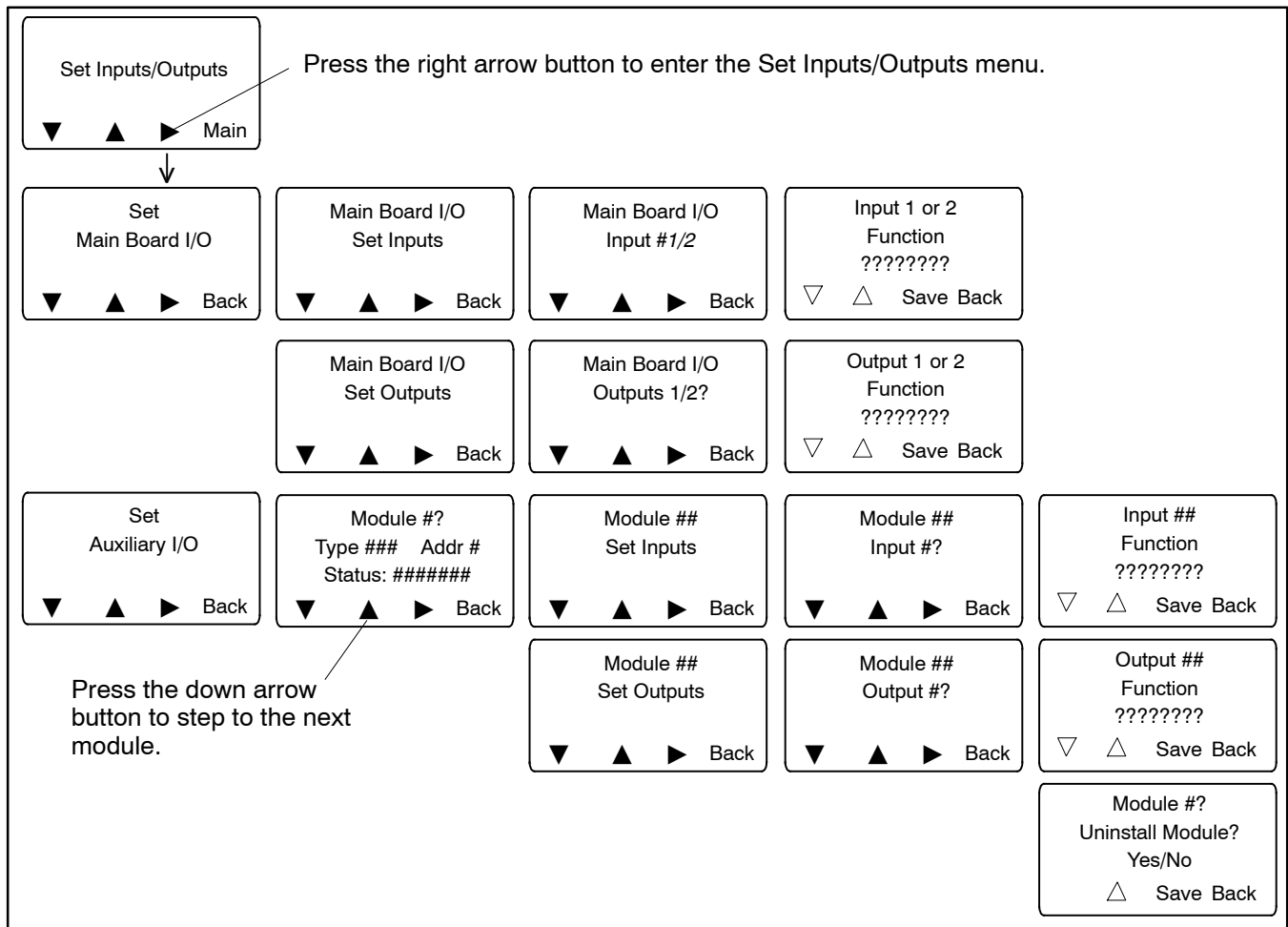

Figure 4-10 Assigning Inputs and Outputs

4.7.3 Input Functions

Available input functions are shown in Figure 4-12. Some inputs will trigger an indicator LED on the user interface and/or display a message on the LCD menu when they are activated.

All of the inputs may be assigned to either one or both of the common alarms.

Note: Some models have factory-set input functions as shown in Figure 4-11. Do not change these settings.

Model or Factory-Installed Accessory	Factory Setting
Load Shed Kit	Forced Transfer to OFF

Figure 4-11 Factory Set Inputs

Forced Transfer to OFF Input. This function requires the load shed accessory installed on a programmed-transition model transfer switch. Activation of this input signals the transfer switch to transfer immediately from Source E to the OFF position. The transfer switch then transfers to Source N if it is available, executing the applicable time delays.

Remote Monitored Inputs. There are four remotely monitored input functions. These functions can be assigned to any of the inputs on either the main logic board or standard/high voltage/high current I/O boards. The state of any or all of these inputs can be monitored using SiteTech™ software or over Modbus.

Peak Shave/Area Protection Input. Starts the generator set and transfers to the standby source, ignoring the engine start time delay. The pre/post-transfer, delayed-transition time delays, and in-phase monitor will be active if enabled.

When the peak shave signal is removed, the load transfers back to the preferred source. The pre/post-transfer, delayed-transition, and engine cooldown time delays, along with the in-phase monitor if enabled, will be executed.

If the standby source is lost during peak shave, the unit will transfer back to the preferred source.

See Section 4.9.7 for information about the Peak Shave TD Bypass.

Remote End Time Delay Input. Allows a remote signal to end an active time delay. The signal ends only the time delay that is active at the time the signal is applied. Repeated signals are required to end additional time delays. Does not end the programmed-transition time delays or an exerciser run.



Remote Test Input. Activating the input starts a test, and deactivating the input stops the test. Tests follow the sequence described in Section 1.7 and Section 2. A remote test can be stopped locally, if necessary, by pressing the END TEST button on the controller.

MPAC firmware versions before 1.10: If a local test is already running, activating the remote test input will stop the local test.

MPAC firmware versions 1.10 or higher: If a local test is already running, activating the remote test input will NOT stop the local test.

The default type for a remote test is unloaded. There are several ways to change the remote test type:

- Use the Set System, Remote Test Loading menu.
- Use a computer and Kohler SiteTech Software to set the Remote Test Loaded parameter.
- Set the remote test type over Modbus.

Programmable Inputs *	 LED	 LED	Display Message
Forced Transfer to OFF* (programmed-transition models only; requires load shed accessory)	None	Flashing	Forced Off
Inhibit Transfer (maintenance mode)	None	Flashing	Inhibit Transfer
Low Battery Voltage	Steady	None	Low Battery Voltage
Peak Shave Mode	None	None	Peak Shave
Remote End Time Delay	None	None	None
Remote Common Alarm	Steady	None	Remote Common Alarm
Remote Test	None	None	Normal test sequence menus. See Section 1.7.
Remote Monitor In #1-4	None	None	None

* See Figure 4-11 for factory-set input functions for selected models. Do not change the factory settings.

Figure 4-12 Available Programmable Inputs

4.7.4 Output Functions

Output functions are shown in Figure 4-13. Information about selected output functions is shown below. Refer to the section number shown in Figure 4-13 for more information about the output function.

In-Phase Monitor Synching Output. Is activated when the in-phase transfer fail or fail to sync time delays expire, indicating that the sources did not synchronize in the allotted time. See Section 4.6.2 for more information about the in-phase monitor. For closed-transition models, customer-supplied equipment used to boost the generator set can be connected to this output. See the transfer switch Installation Manual and Section 7.2.1 for output connection information.

Note: The In-phase Transfer Fail and/or Fail to Sync time delays are set in the Set Sources menu. See Section 4.6.

Load Control Output, 1-9. Connect up to nine loads that can be connected or disconnected using time-based load control. Assign load control outputs 1 through 9 to the corresponding outputs on the main board or I/O modules, and then go to the Time Delay setup menu to set up the load control sequences. See Section 4.5 for the Time Delay setup menus, and Section 4.5.5 for more information about load control.

Maintenance Mode. A DIP switch on the controller circuit board allows a service technician to place the controller into maintenance mode. See the Service Manual for more information.

MBUS-Controlled Outputs. There are four Modbus-Controlled Output functions. These four functions can be assigned to any of the outputs on either the main logic board or the optional I/O boards. The state of any or all of these four functions can be controlled and monitored via Modbus messages only.

Source E Engine Start Signal. An alternative to the engine start contacts on the transfer switch.

Programmable Output	Type	See Section
Alarm Is Silenced	Monitor	7.2.3
Audible Alarm	Control	7.2.3
Aux Switch Fault	Fault	1.10
Aux Switch Open	Fault	1.10
Common Alarm Active (1 and 2)	Fault	4.8
Contactor in OFF position	Monitor	—
Contactor in Preferred Position	Monitor	—
Contactor in Source E Position	Monitor	—
Contactor in Source N Position	Monitor	—
Contactor in Standby Position	Monitor	—
Exerciser Active	Monitor	4.4, 2.2.2
Fail to Acquire Standby	Fault	1.10
Fail to Open Source1	Fault	2.4.5
Fail to Close Source1	Fault	2.4.5
Fail to Open Source2	Fault	2.4.5
Fail to Close Source2	Fault	2.4.5
Fail to Transfer	Fault	1.10
IPM (In-Phase Monitor) Synching	Control	4.7.4, 4.6.2
Load Bank Control Active	Control	4.7.4
Load Control Active	Monitor	4.5.5
Load Control Out 1-9	Control	4.5.5
Low Battery (external battery)	Monitor	7.2.2
Maintenance Mode	Monitor	—
MBUS Control RDO #1-4	Control	4.7.4
Module (I/O) Lost Comm	Fault	1.10
Non-Emergency Transfer	Monitor	—
Not in Auto	Monitor	1.3.4
Peak Shave Active	Monitor	4.9.7
Preferred Source Available	Monitor	4.6.5
Source E (Phase) Rotation Error	Fault	—
Source E Loss of Phase	Fault	—
Source E Over Frequency	Fault	4.6.5
Source E Over Voltage	Fault	4.6.5
Source E Start Signal	Control	4.7.4
Source E Under Frequency	Fault	4.6.5
Source E Under Voltage	Fault	4.6.5
Source E Voltage Unbalance	Fault	4.6.5
Source N (Phase) Rotation Error	Fault	—
Source N Loss of Phase	Fault	—
Source N Over Voltage	Fault	4.6.5
Source N Under Voltage	Fault	4.6.5
Source N Voltage Unbalance	Fault	4.6.5
Standby Source Available	Monitor	4.6.5
Test Mode Active	Monitor	1.7

Figure 4-13 Available Programmable Outputs

Load Bank Control Active. The load bank control output is a C form contact that can be used to apply a load to the generator set during an unloaded exercise or test. The load bank control output is active during each unloaded test and unloaded exercise. See Figure 4-14.

The load bank control output closes or opens a contact that can be used to signal the load bank controller to operate. Connect the normally open or normally closed output contact to the load bank controller as required for proper operation. Refer to the connection instructions provided by the load bank manufacturer.

If the Normal source is lost during an exercise period, the load bank control output is deactivated to remove the load bank and allow the transfer of the building load to the emergency source.

4.7.5 User-Defined I/O Descriptions

The controller can store a 19-character string description for each of the 9 user controllable/monitored I/Os. Use a personal computer with Kohler® SiteTech™ software to enter descriptions. Descriptions are only available for reading and writing through SiteTech and over Modbus. Descriptions are not used by the controller.

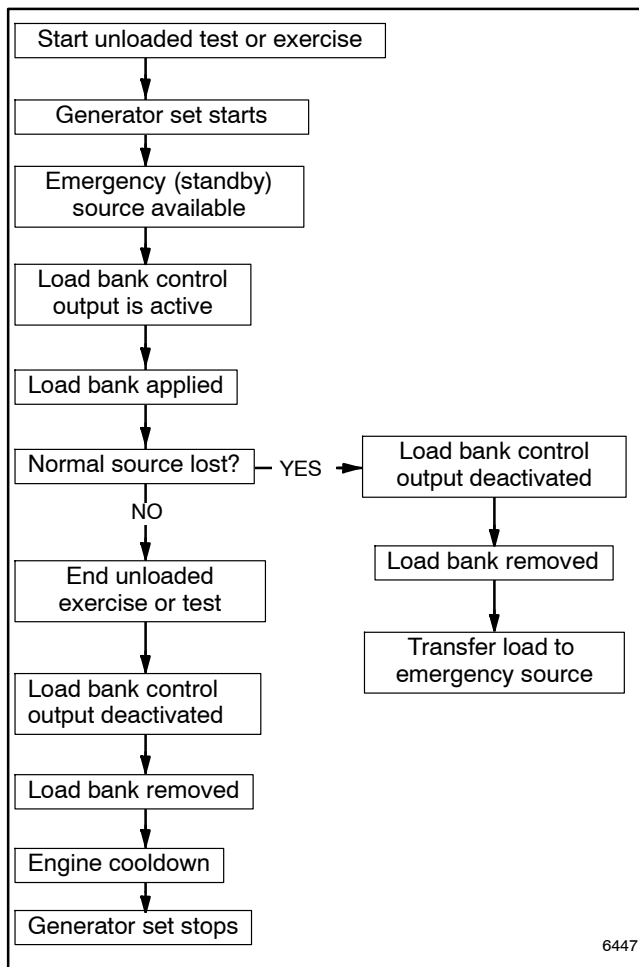

Figure 4-14 Load Bank Control Sequence

4.8 Common Alarms

Use the Common Alarms setup menu to assign events to the controller's common alarm groups. See Figure 4-15 for a list of functions that can be assigned to the common alarm and the audible alarm.

Alarm Descriptions	
Aux Switch Fault*	Src E Over Freq
Aux Switch Open*	Src E Over Voltage
Contactora in Off	Src E Rotation Err *
Contactora in Pref	Src E Under Freq
Contactora in Src E	Src E Under Voltage
Contactora in Src N	Src E Voltage Unbal
Contactora in Stby	Src N Loss of Phase
Exerciser Active	Src N Over Voltage
External Battery Low *†	Src N Rotation Err *
Fail to Acquire Stby *	Src N Under Voltage
Fail to Transfer *	Src N Voltage Unbal
IPM Synching	Stby Src Available
Load Bank Control	System Ready
Load Control Active	Test Mode Active
Non-Emergency Trans	Critical Service Required
Not in Auto	Man Transfer Waiting
Peak Shave Active †	Module Lost Comm *
Pref Src Available	Non-Critical Service
Remote Common Alarm *	Source E Available
Remote Monitor In #1 - 4	Source N Available
Src E Loss of Phase	MBUS-Control RDO #1 - 4

* Assigned to Critical Service Required alarm
 † Assigned to Non-Critical Service Required alarm

Figure 4-15 Alarm Descriptions

4.8.1 Common Alarm Output

Functions can be assigned to two alarm groups. The groups can then be assigned to programmable outputs, if desired. Any function assigned to the Common Alarm triggers the Common Alarm programmable output. See Section 4.7, Programmable Inputs and Outputs, for more information about programmable outputs.

4.8.2 Audible Alarm

The audible alarm setting requires the Alarm Module accessory for operation. See Section 7.2.3 for more information about the alarm module.

Enable the audible alarm for any alarm function by navigating to the Alarm Description, Common, Audible menu. press the open up arrow button until the display shows *Audible Y* and Y or N for Common as desired. press *Save*.

4.8.3 Chicago Alarm

The Chicago Alarm function requires the alarm module accessory.

The Chicago alarm function is a programmable feature of the MPAC 1200 controller. The alarm is active when the transfer switch is in the Emergency position. The alarm can be silenced via the user interface, which will also activate a light indicating the alarm-silenced condition. The alarm silenced light is deenergized when the transfer switch returns to the Normal position.

For Chicago Alarm Mode, use the Common Alarm Setup menu to assign the necessary faults and conditions to the audible alarm. Be sure to assign the Contactora in Standby function to trigger the audible alarm.

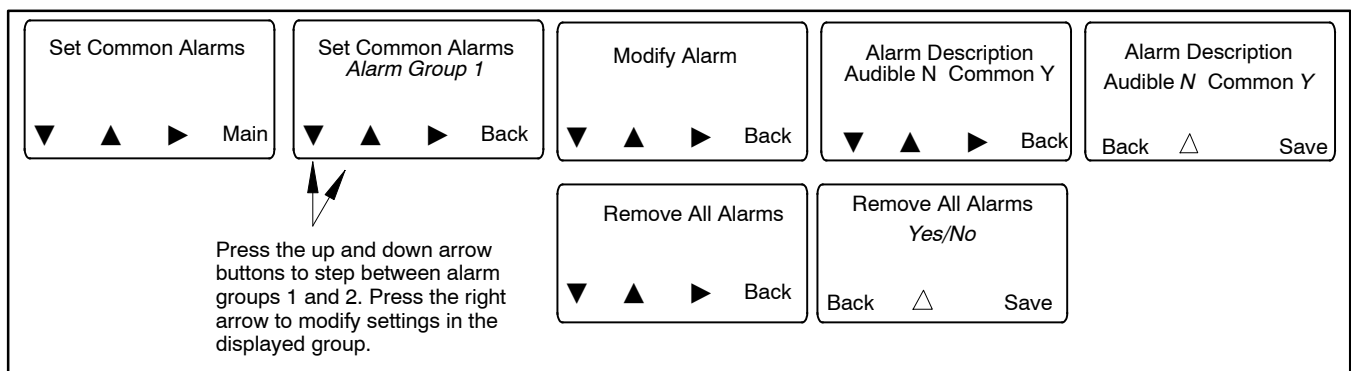

Figure 4-16 Setting Common Alarms

4.9 Set System

See Figure 4-19 for the Set System menus.

4.9.1 Default Settings

The system parameter factory settings are shown in Figure 4-17.

System Parameter	Factory Setting
Standard or programmed transition	Set to order †
Single/three phase	Set to order †
Operating voltage	Set to order †
Operating frequency (50 or 60 Hz)	Set to order †
Phase rotation	ABC
Commit to transfer (yes or no)	No
Rated current	Set to order †
Operating mode	Utility-to-Generator
In-phase monitor	Disabled
In-phase monitor transfer angle	5°
Transfer mode (automatic or non-automatic) *	Set to order
* The transfer mode (automatic or non-automatic) cannot be changed in the field.	
† See the ATS nameplate.	

Figure 4-17 Factory Settings, System Parameters

4.9.2 Source Type/Source Type

Set the source type selection for the types of sources used:

- One utility source and one generator set

4.9.3 Transition Type

The transition type is factory set for each model and should not require change except in the case of controller replacement. Select standard, programmed, or closed transition, if necessary.

Note: The transition type is determined by the ATS model as indicated Figure 4-18. Do not attempt to change the transition type to one that is not listed for your model.

Model	Transition Type
KCS	Standard
KSS	
KSSB	
KCP	Programmed
KSP	
KCC	Closed

Figure 4-18 Transition Types by Model

Standard-transition (also referred to as open transition) models use a break-before-make transfer that does not require source synchronization for transfer between available sources.

Programmed-transition models stop momentarily in the OFF position during transfer between two available sources. The time in the OFF position can be adjusted using the transfer time delays. See Section 4.5.

Closed-transition models provide make-before-break transfer for uninterrupted power to the load when both sources are available. The sources are monitored for synchronization and are paralleled for approximately 100 milliseconds during the transfer.

Programmed-transition override (for closed-transition models only). When closed transition is selected, the programmed-transition override menu appears. The override function operates if the sources do not synchronize before the Inphase Transfer Fail time delay expires. In this case, the transfer switch can be set to transfer to the other source using programmed-transition mode, with a short interruption in power to the load during transfer.

- Select Automatic to set the unit to initiate a programmed-transition transfer automatically after the Inphase Transfer Fail time delay expires.
- Select Manual to require an operator to initiate a programmed-transition transfer by pressing a button after the Inphase Transfer Fail time delay expires.

If a manual transfer is not initiated, the controller continues to monitor the sources and transfers if synchronization occurs.

- Set the Xfr Off>Stby (transfer off-to-standby) time delay for the desired “off” time during the transfer. See Section 4.5 for the default time delays.

4.9.4 Rated Current

This value is factory-set for each unit and should not require adjustment. If necessary, enter the rated current from the transfer switch nameplate.

4.9.5 Transfer Commit

The transfer commit setting controls operation if the preferred source returns after a transfer to standby sequence has been initiated but not completed (i.e., preferred returns during the transfer time delay).

- The Commit setting allows the complete transfer sequence to execute even if the preferred source returns before the load has been transferred to standby.

- The No Commit setting causes the transfer sequence to be cancelled without transfer if the preferred source returns before the load has been transferred to standby.

4.9.6 Remote Test Loading

Select loaded or unloaded for a remote test sequence initiated by a remote test input.

4.9.7 Peak Shave TD Bypass

Peak Shave Operation. When the peak shave input is activated, the generator set starts immediately, bypassing the engine start time delay. The pre/post-transfer time delays, programmed-transition time delays, and in-phase monitor are active if enabled. The ATS transfers the load to the standby source.

Peak Shave TD Bypass. In normal operation, retransfer from standby to preferred is delayed (15 minutes default setting) to ensure that the preferred source is stable before transfer. The Peak Shave TD

Bypass allows you to skip the retransfer time delay after peak shave operation.

When the peak shave input is removed, the ATS transfers back to the preferred source according to the Peak Shave TD Bypass setting:

- If the Peak Shave TD Bypass is *enabled*, the retransfer (standby to preferred) time delay is bypassed when the peak shave signal is removed. Notice that by enabling the TD bypass, you are ordering the system to skip the retransfer time delay.
- If the Peak Shave TD Bypass is *disabled*, the retransfer (standby to preferred) time delay executes before the ATS transfers back to the preferred source. Transfer is delayed by the retransfer time delay. The retransfer time delay is adjustable, with a 15-minute factory setting.

If the standby source is lost during peak shave operation, the unit transfers back to the preferred source.

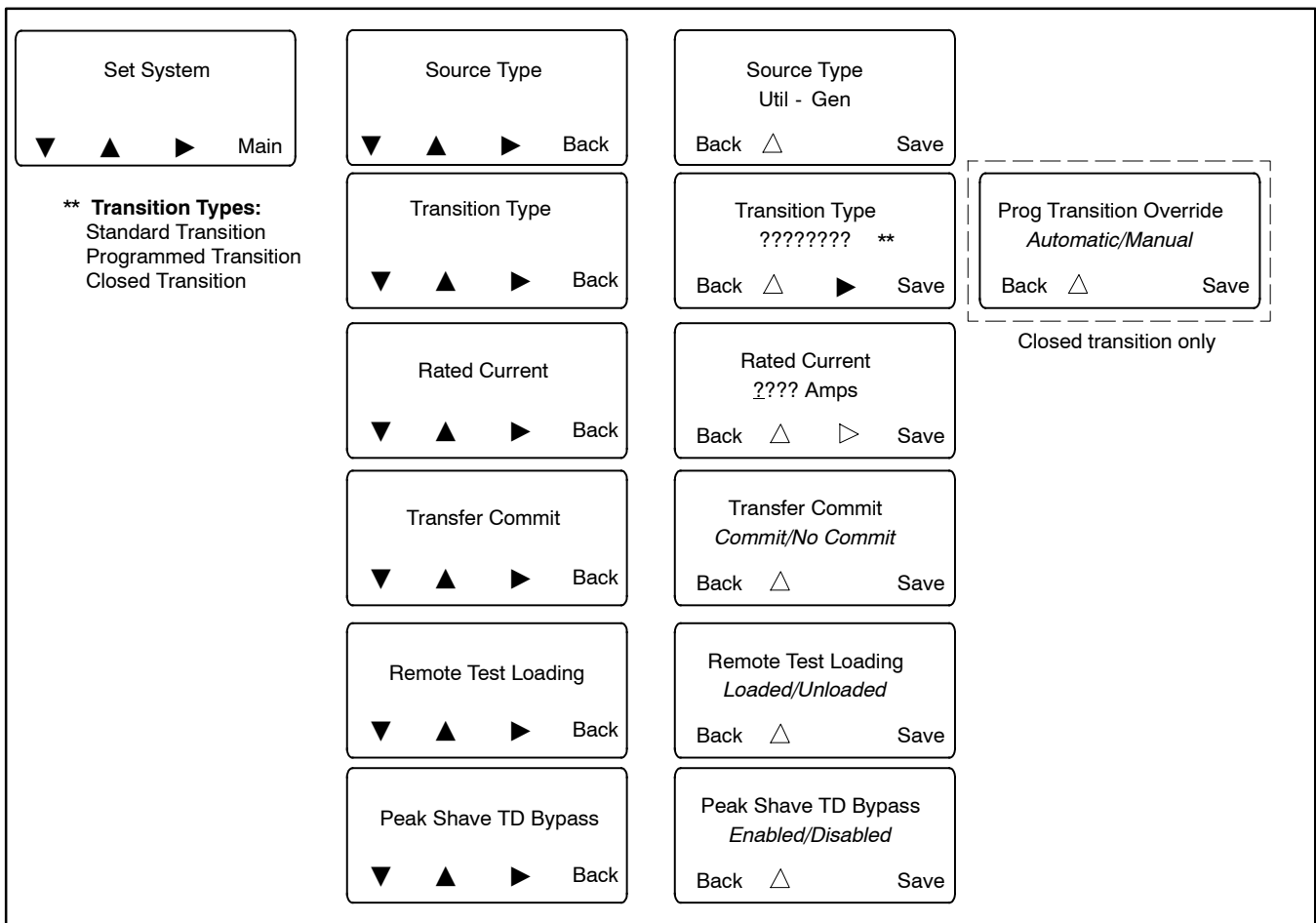

Figure 4-19 Set System

4.10 Communications

Use the Set Communications menu to set the communication parameters for serial or ethernet connections. See Section 5, Communications, for instructions.

4.11 Set Passwords

Two passwords control access to the Test and Setup menus. Passwords are 4-digit numerical values ranging from 0000 to 9999. The default passwords are set to 0000. Change the passwords to prevent unauthorized access to the Test initiation menus and system settings.

Note: A DIP switch on the controller's main logic board allows the setup password to be disabled. The DIP switch does not disable the test password.

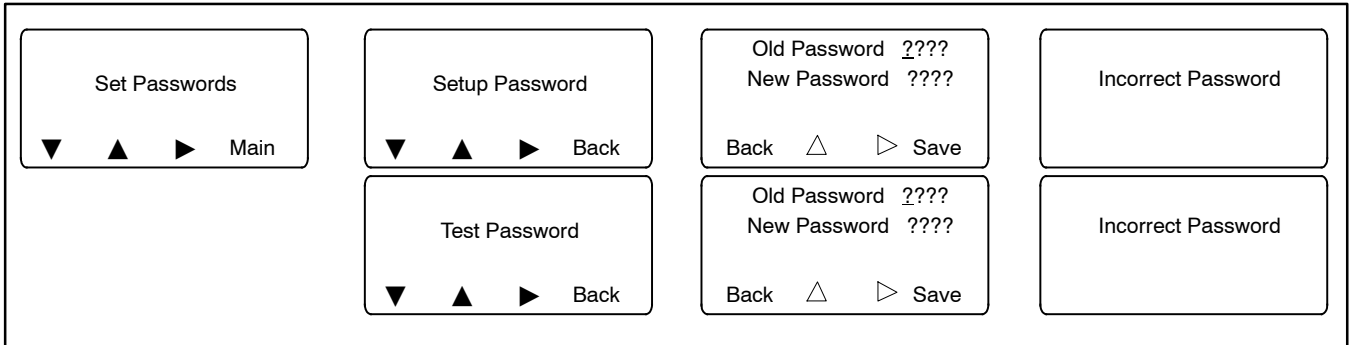
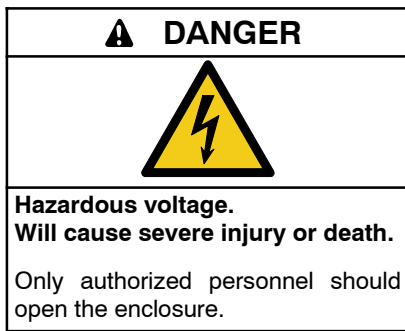

Figure 4-20 Setting/Changing Passwords

4.12 Calibration



Testing live electrical circuits. Hazardous voltage or current will cause severe injury or death. Have trained and qualified personnel take diagnostic measurements of live circuits. Use adequately rated test equipment with electrically insulated probes and follow the instructions of the test equipment manufacturer when performing voltage tests. Observe the following precautions when performing voltage tests: (1) Remove all jewelry. (2) Stand on a dry, approved electrically insulated mat. (3) Do not touch the enclosure or components inside the enclosure. (4) Be prepared for the system to operate automatically.
(600 volts and under)

The transfer switch voltage and current sensing (if equipped) are calibrated at the factory. If voltage recalibration is necessary, refer to the transfer switch installation manual or service manual for instructions to check the voltages and then use the Calibration menu to enter the measured values. See Figure 4-21.

The current sensing accessory is required in order for the transfer switch to measure and display the current values. See Section 7.4. Use a clamp-on current sensing meter to measure the current and enter the measured values through the Setup Menu- Calibration shown below.

For three-phase models, the voltage and current for all phases will appear and can be calibrated.

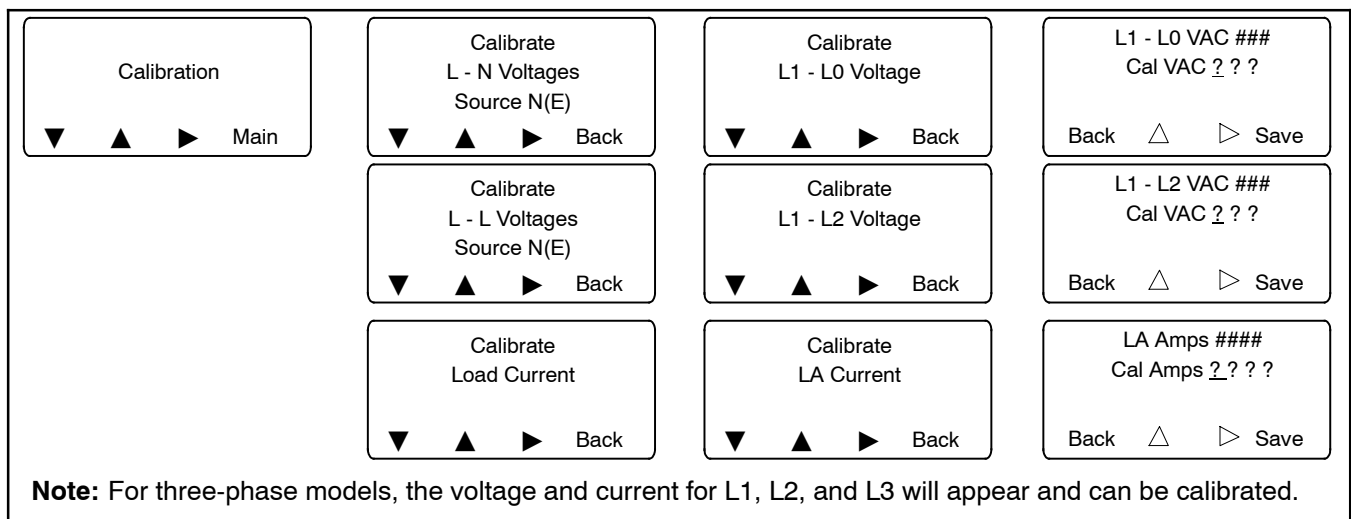

Figure 4-21 Calibration

4.13 Setting the Current to Zero

The metered current can be set to zero. This can be done with any screen showing, but zeroing the current while viewing the current metering screen is recommended. See the Operation Menus shown in Section 1.6.

Procedure to Set the Current to Zero

1. Remove all loads from the transfer switch.
2. Press buttons 1 and 4 on the controller. See Figure 4-22.

4.14 Reset Data

The Reset Data menu allows the service technician to reset the maintenance records, event history, and other items. See Section 1.12.

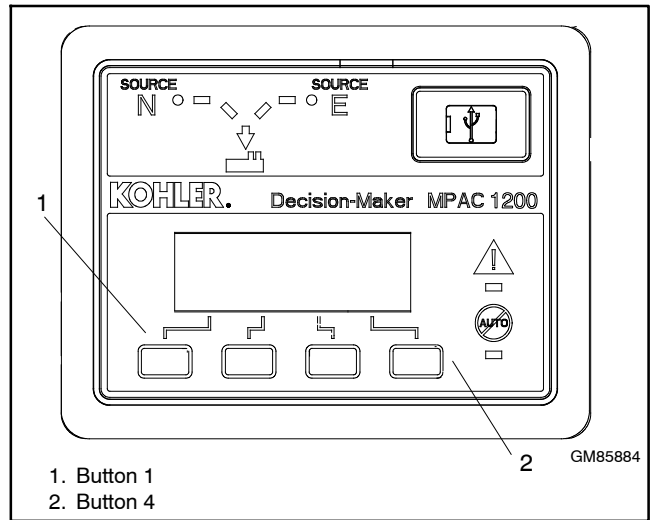

Figure 4-22 User Interface Panel

Section 5 Communications

5.1 Introduction

The Decision-Maker® MPAC 1200 controller is equipped with a USB port and a Modbus port with an RS-485 connector. An optional Ethernet accessory board is available.

Kohler authorized distributors and dealers can use a personal (laptop) computer with Kohler® SiteTech™ software to view and adjust controller parameters, view event history, import and export parameter files, and update controller firmware. See TP-6701, SiteTech Software Operation manual, for instructions.

The controller uses Modbus® TCP/IP communication protocol over the Ethernet port and Modbus® RTU communication protocol over the serial port. The Modbus registers are available in the Modbus Protocol manual. See the List of Related Materials.

The controller can send encapsulated Modbus messages over the network connection. Only one Modbus address can be assigned to the controller, regardless of the communication port or protocol being used.

Note: Modbus® applications require a Modbus software driver written by a trained and qualified systems programmer.

5.2 Connections

5.2.1 USB Port SiteTech Connection

A personal computer and Kohler SiteTech software can be used for changing controller settings. Use a USB cable to connect the controller to a personal computer.

See Figure 5-1 for the USB port location on the front of the controller assembly. Remove the small port cover and use a USB cable with a mini-B connector to connect the controller's USB port to the computer.

See TP-6701, SiteTech Software Operation Manual, for instructions to use the software. Disconnect the USB cable from the controller and replace the protective cover when finished.

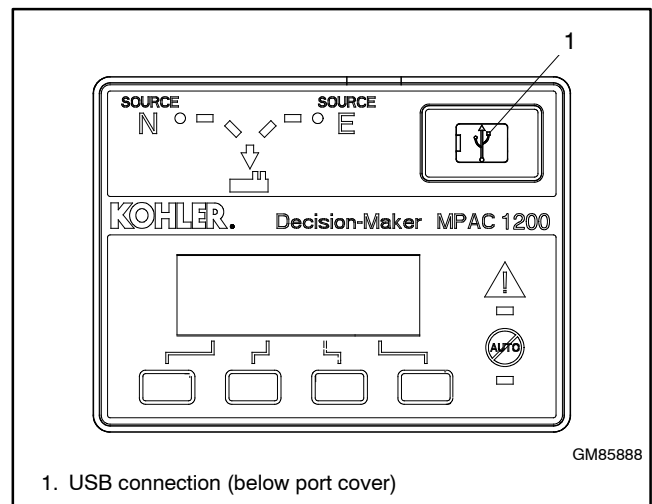

Figure 5-1 USB Connection (for SiteTech)

5.2.2 Modbus Connection

The controller is equipped with a Modbus port with an RS-485 connector. See Figure 5-2 for the RS-485 Modbus connector location.

Use serial connections to TB2 on the main logic board to connect the transfer switch to a personal computer for system monitoring, an optional remote annunciator, or a Modbus network. See the transfer switch Installation Manual for connection instructions.

The serial port is an isolated RS-485 port with connection speeds of 9.6, 19.2, and 57.6 kbps.

Use Modbus RTU (remote terminal unit) protocol for communication through the serial port. A map of the Modbus codes for this controller is available. Contact your local distributor/dealer.

Note: Modbus® applications require a Modbus software driver written by a trained and qualified systems programmer.

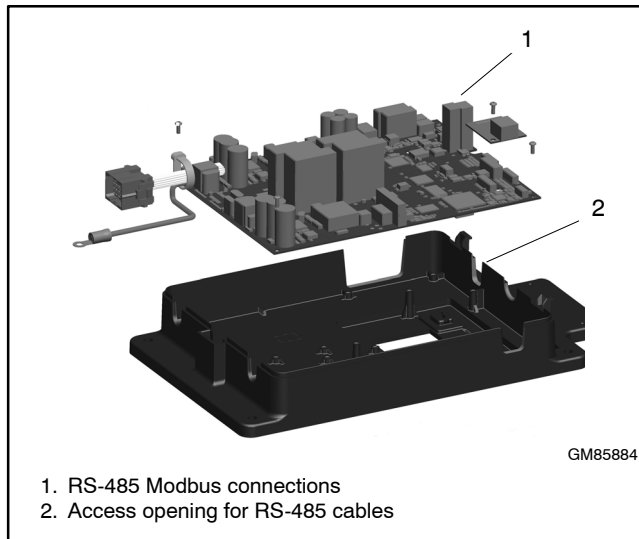

Figure 5-2 Modbus Connections (controller cover removed for illustration only)

5.2.3 Ethernet Connection (Optional)

The Ethernet communication accessory board is required for connection to the Ethernet. The Ethernet communication board is an optional accessory for the MPAC 1200 controller. The communication board connects to the controller board as shown in Figure 5-3.

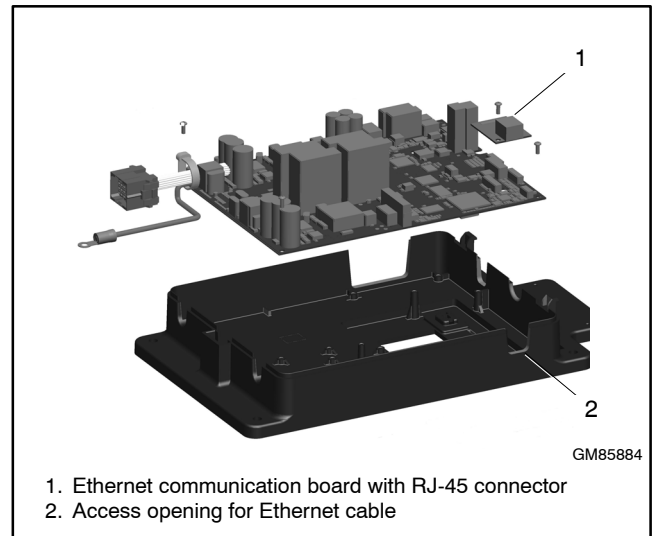

Figure 5-3 Ethernet Board (controller cover removed for illustration only)

The Ethernet communication accessory board allows the transfer switch to be connected to a building's Ethernet network to communicate with personal computers connected to the same subnet. See the transfer switch Installation manual for connection instructions.

Note: For an ethernet connection, obtain an IP address and subnet number from the local system administrator.

Use the Setup menus or a personal computer connected to the controller's USB port and Kohler SiteTech software to set the communication parameters. Assign a port number, IP address, and subnet mask number from the controller's front panel. The Ethernet communication board may have a default IP address assigned at the factory for test purposes. **Change the IP address to an address owned by the user.** See Section 4.10 for instructions to set the communication parameters.

The controller can communicate with up to five (5) simultaneous TCP/IP (ethernet) connections. These five connections do not include the RS-485 serial port. In the extreme case, five users may be communicating with the controller via TCP/IP network connections and another may be communicating through the serial port, for a total of six (6) communication channels. As the controller is asked to communicate with more and more outside devices, the communication will slow down.

5.3 Communications Setup

Use the controller display and keypad or a personal computer with Kohler® SiteTech™ software connected to the USB port to set the communication parameters for serial or ethernet connections. The controller uses Modbus® communication protocol.

5.3.1 Modbus Serial Communication Setup

Set the following communication parameters for serial communication. Also see Figure 5-6 for a summary of these settings.

Note: Modbus® applications require a Modbus software driver written by a trained and qualified systems programmer.

Modbus Enabled. Set to True to allow Modbus communication.

Modbus Baud Rate. Required for serial connections. The baud rate must match the baud rate of the connected PC.

Modbus Slave Addr. Assign a unique address between 001 and 247 to the serial port.

5.3.2 Network Communication Setup

Work with your local network administrator to set the following communication parameters for Ethernet communication.

See Figure 5-6 for a summary of the following settings.

DHCP Enabled. Factory set to False. Setting this parameter to True enables dynamic host configuration protocol (DHCP), which allows a DHCP server to automatically assign a dynamic IP address, subnet mask, and default gateway to the MPAC controller. Work with your local network administrator to determine whether DHCP is required.

Static IP Address. The transfer switch may have a default IP address assigned at the factory. **Change the IP address to a static IP address owned by the user.** Obtain an IP address, subnet mask, and default gateway information from the local network administrator.

Static Subnet Mask. Obtain subnet mask information from the local network administrator. All devices that communicate with each other on the same local network must use the same subnet mask.

Static Default Gateway. Obtain gateway information from the local network administrator.

DHCP Server. Displayed for information only. Provide this value to the network administrator if there are problems with DHCP.

Modbus TCP Unit ID. The unit ID is required for Modbus over TCP communication. The unit ID for TCP communication is analogous to the Modbus address for serial communication through the RS-485 ports. The factory default setting is 2.

Modbus TCP Server Enabled. Enable (set to True) to enable TCP if the transfer switch is connected to a network for TCP/IP communication (for example, ethernet communication).

MAC address. The MAC hardware address is factory-set. It can be seen in the View>Communications Setup menus but not viewed or changed in the setup menus.

5.3.3 Setup Using the Controller Keypad

Use the Set Communications menu to set the communication parameters for serial or ethernet connections. See Figure 5-4.

The Modbus port on the controller circuit board is Port 0.

5.3.4 Setup Using SiteTech

Use a USB cable, male USB A to male USB mini-B, to connect the MPAC controller to a personal computer. Then use Kohler SiteTech software to set the communication parameters for serial or Ethernet connections. See Figure 5-5 and TP-6701, SiteTech Software Operation Manual.

SiteTech software is available only to Kohler authorized distributor and dealers.

Some parameter names in SiteTech are slightly different than what is shown the controller display. Figure 5-6 shows both names.

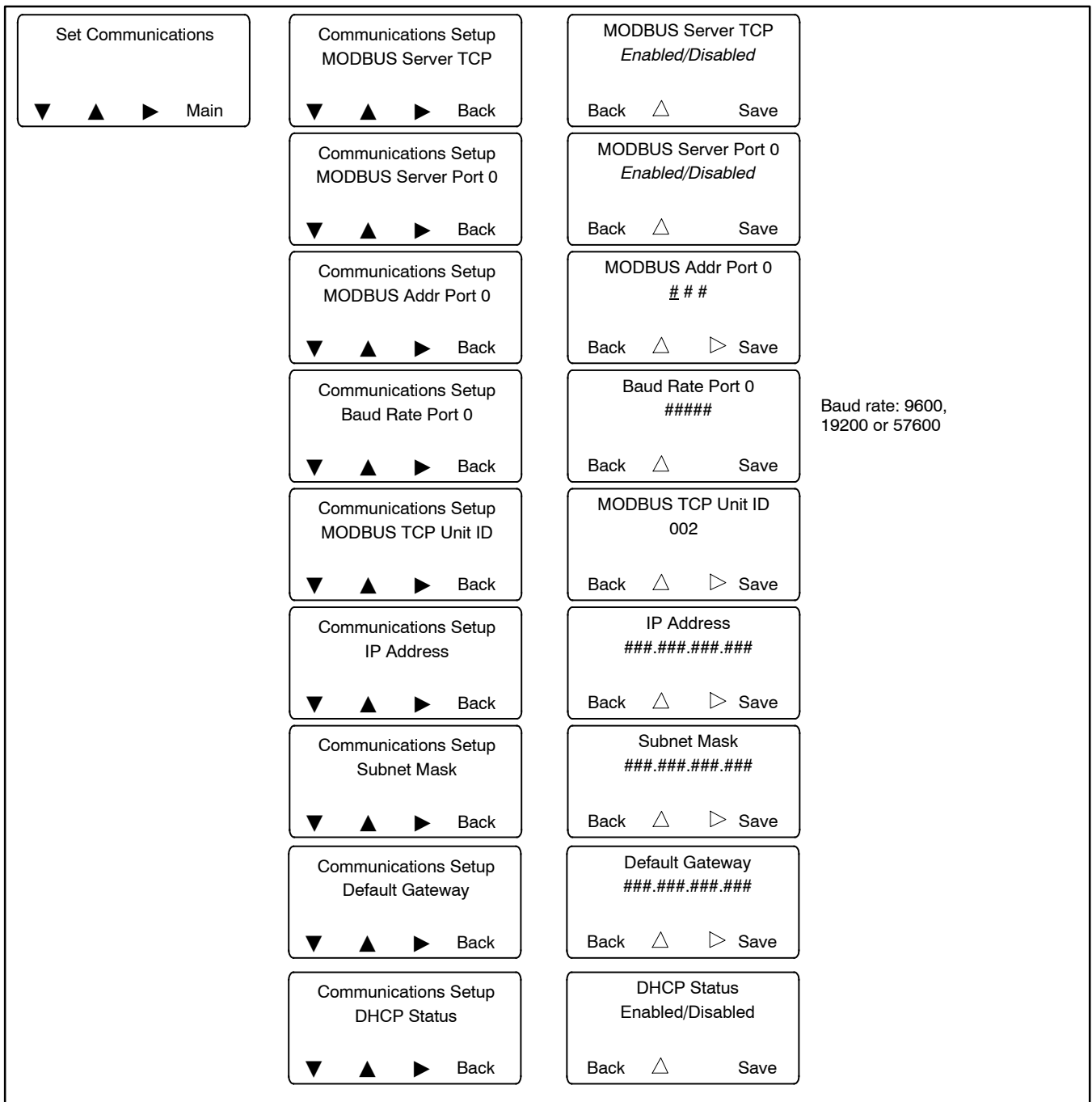

Figure 5-4 Communications Setup from the Controller Display and Keypad

Kohler SiteTech 6.2.11

File Device

+ Add Device
 ⚙️ Connect Device
 ▶ Start Engine
 🔄 Update Firmware
 ⚙️ Calibrate
 📊 Gauges
 📄 Manage Device
 📄 Manage Parallel Devices
 ⚡ Sync
 ⚡ Real Power
 ⚡ Reactive Power
 📄 Apply Changes
 🗑️ Disconnect Device
 🗑️ Remove Device
 ⏸ Stop Engine
 ⚙️ Notification Setup
 🔒 Set Mpac Password
 ⚙️ Reset Faults
 ⚙️ Reset to Defaults
 🚫 Reset Favorites
 📄 Views

MPAC Dm 1200

KOHLER MPAC-Dm

Export Events Parameters Common Alarms

Time Based Load Control Exercise Setup Prog. Inputs Prog. Outputs

Parameter	MPAC DM 1200
Modbus	
Modbus Enabled	True
MPAC Modbus Baud Rate	9600 b/s
Modbus Slave Address	2
Modbus Parity	0
Modbus Stop Bits	1
Network Configuration	
DHCP Enabled	False
Static IP Address	*
Static Subnet Mask	*
Static Default Gateway	*
DHCP Server	*
Modbus Tcp Unit Id	2
Modbus Tcp Server Enabled	True
Network Status	

Event History

Status	Event Description	Date and Time Received	Date and Time	Event Description	Parameter1	Parameter2
1 Device 1 Connected 4 Events						

* Obtain from the local network administrator

Figure 5-5 Communications Setup using Kohler® SiteTech™ Software (typical screen shown)

Setting as shown in SiteTech and on the controller display	Range	Default	Notes
SiteTech: Modbus Enabled Controller: Modbus Server Port 0	True or False Enabled or Disabled	True Enabled	Enable for network communication through the ethernet port.
SiteTech: Modbus Baud Rate Controller: Baud Rate	9600, 19200, 57600	19200	Baud rate in bits per second for serial communication between the controller and a personal computer's COM port.
SiteTech: Modbus Slave Address Controller: Modbus Address	001-247	0	Address for the RS-485 serial port (on the logic board).
SiteTech: Modbus Parity Controller: (not shown on controller)	Read only	None	Not adjustable.
SiteTech: Modbus Stop Bits Controller: (not shown on controller)	Read only	1	Not adjustable.
SiteTech: DHCP Enabled Controller: DHCP Status	True or False Enabled or Disabled	False Disabled	Dynamic host communication protocol. Enable if required; check with your local network administrator.
SiteTech: Static IP Address Controller: IP Address	See notes.	*	Obtain from your local network administrator. Every device on the network must have a unique IP address.
SiteTech: Static Subnet Mask Controller: Subnet Mask	See notes.	*	Obtain from your local network administrator. All devices that communicate with each other on the same local network must use the same subnet mask.
SiteTech: Static Default Gateway Controller: Default Gateway	See notes.	*	Obtain from your local network administrator.
SiteTech: DHCP Server Controller: (not shown on controller)	Read only	—	Displayed in SiteTech for information only.
SiteTech: Modbus TCP Unit ID Controller: Modbus TCP Unit ID	001-247	002	The unit ID is required for Modbus over TCP communication.
SiteTech: Modbus TCP Server Enabled Controller: Modbus Server TCP	True or False Enabled or Disabled	True Enabled	Enable (set to True) to enable TCP/IP communication (for example, Ethernet communication).
SiteTech: MAC Address Controller: MAC Address (view menu only)	Not Adjustable	Factory-set	Hardware address, entered at the factory. Not adjustable.
* Do not use the factory settings for IP address, subnet mask, or default gateway. Obtain these settings from your local network administrator.			

Figure 5-6 Communication Parameters

5.4 Parameter Files

The parameter setting files can be exported to a personal computer (PC) using Kohler® SiteTech™ software. Use a USB cable to connect the PC to the controller. The resulting file can be opened using a spreadsheet program on your computer. Modification of the settings in the file is not recommended.

Parameter settings can be loaded onto the MPAC controller from a saved file. This can be useful for service or controller replacement. See the SiteTech Operation Manual for instructions to export and import files.

5.5 Controller Firmware Updates

Kohler may release updated versions of the controller firmware. A personal (laptop) computer connected to the USB port and Kohler® SiteTech™ software are required for updating the firmware on the controller. Have an authorized distributor/dealer load an updated version of the controller firmware, if necessary. See TP-6701 for instructions to update the firmware.

Notes

Section 6 Scheduled Maintenance

6.1 Introduction

Regular preventive maintenance ensures safe and reliable operation and extends the life of the transfer switch. Preventive maintenance includes periodic testing, cleaning, inspection, and replacement of worn or missing components. Section 6.4 contains a service schedule for recommended maintenance tasks.

A local authorized distributor/dealer can provide complete preventive maintenance and service to keep the transfer switch in top condition. Unless otherwise specified, have maintenance or service performed by an authorized distributor/dealer in accordance with all applicable codes and standards. See the Service Assistance section in this manual for how to locate a local distributor/dealer.

Keep records of all maintenance or service.

Replace all barriers and close and lock the enclosure door after maintenance or service and before reapplying power.

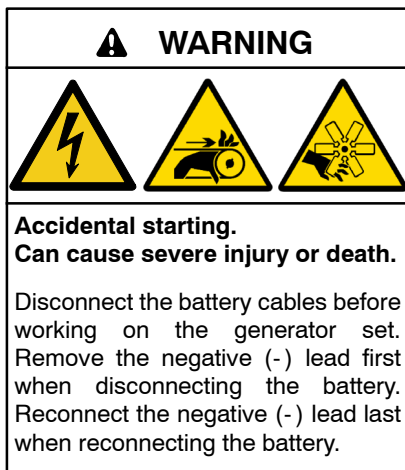

Disabling the generator set. Accidental starting can cause severe injury or death. Before working on the generator set or equipment connected to the set, disable the generator set as follows: (1) Move the generator set master switch to the OFF position. (2) Disconnect the power to the battery charger. (3) Remove the battery cables, negative (-) lead first. Reconnect the negative (-) lead last when reconnecting the battery. Follow these precautions to prevent starting of the generator set by an automatic transfer switch, remote start/stop switch, or engine start command from a remote computer.

Disabling the generator set. Accidental starting can cause severe injury or death. Before working on the generator set or equipment connected to the set, disable the generator set as follows: (1) Press the generator set off/reset button to shut down the generator set. (2) Disconnect the power to the battery charger, if equipped. (3) Remove the battery cables, negative (-) lead first. Reconnect the negative (-) lead last when reconnecting the battery. Follow these precautions to prevent the starting of the generator set by the remote start/stop switch.

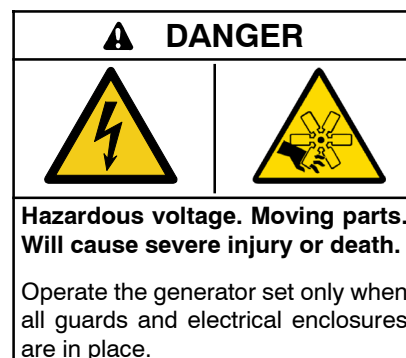
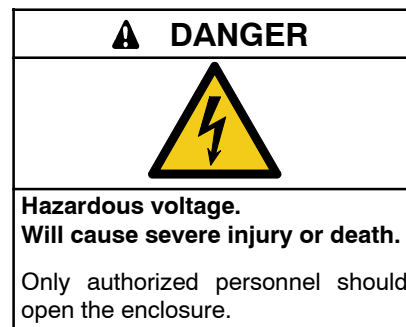
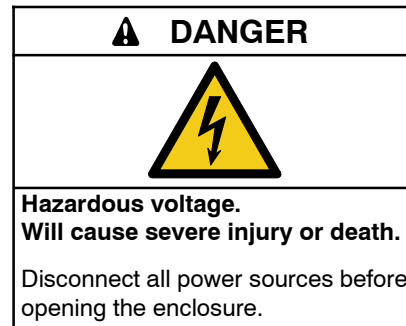

Grounding electrical equipment. Hazardous voltage will cause severe injury or death. Electrocutation is possible whenever electricity is present. Ensure you comply with all applicable codes and standards. Electrically ground the generator set, transfer switch, and related equipment and electrical circuits. Turn off the main circuit breakers of all power sources before servicing the equipment. Never contact electrical leads or appliances when standing in water or on wet ground because these conditions increase the risk of electrocution.

Servicing the transfer switch. Hazardous voltage will cause severe injury or death. Deenergize all power sources before servicing. Turn off the main circuit breakers of all transfer switch power sources and disable all generator sets as follows: (1) Move all generator set master controller switches to the OFF position. (2) Disconnect power to all battery chargers. (3) Disconnect all battery cables, negative (-) leads first. Reconnect negative (-) leads last when reconnecting the battery cables after servicing. Follow these precautions to prevent the starting of generator sets by an automatic transfer switch, remote start/stop switch, or engine start command from a remote computer. Before servicing any components inside the enclosure: (1) Remove all jewelry. (2) Stand on a dry, approved electrically insulated mat. (3) Test circuits with a voltmeter to verify that they are deenergized.

Short circuits. Hazardous voltage/current will cause severe injury or death. Short circuits can cause bodily injury and/or equipment damage. Do not contact electrical connections with tools or jewelry while making adjustments or repairs. Remove all jewelry before servicing the equipment.

NOTICE

Electrostatic discharge damage. Electrostatic discharge (ESD) damages electronic circuit boards. Prevent electrostatic discharge damage by wearing an approved grounding wrist strap when handling electronic circuit boards or integrated circuits. An approved grounding wrist strap provides a high resistance (about 1 megohm), *not a direct short*, to ground.

6.2 Testing

6.2.1 Weekly Generator Set Exercise

Use the exerciser to start and run the generator set under load once a week to maximize the reliability of the emergency power system. See Section 4.4 for instructions to program the exerciser.

6.2.2 Monthly Automatic Control System Test

Test the transfer switch's automatic control system monthly. See Section 1.8 for the test procedure.

- Verify that the expected sequence of operations occurs as the switch transfers the load to the emergency source when a preferred source failure occurs or is simulated.
- Observe the indicator LEDs included on the transfer switch to check their operation.

- Watch and listen for signs of excessive noise or vibration during operation.
- After the switch transfers the load to the standby source, end the test and verify that the expected sequence of operations occurs as the transfer switch retransfers to the preferred source and signals the generator set to shut down after a cooldown period.
- On programmed-transition units, verify that the time delay in the OFF position functions during transfer to the standby source and transfer back to the preferred source.

6.3 Inspection and Service

Contact an authorized distributor/dealer to inspect and service the transfer switch annually and also when any wear, damage, deterioration, or malfunction of the transfer switch or its components is evident or suspected.

6.3.1 External Inspection

Keep the transfer switch clean and in good condition by performing a weekly general external inspection of the transfer switch for any condition of vibration, leakage, excessive temperature, contamination, or deterioration. Remove accumulations of dirt, dust, and other contaminants from the transfer switch's external components or enclosure with a vacuum cleaner or by wiping with a dry cloth or brush.

Note: Do not use compressed air to clean the transfer switch because it can cause debris to lodge in the components and damage the switch.

Tighten loose external hardware. Replace any worn, missing, or broken external components with manufacturer-recommended replacement parts. Contact a local authorized distributor/dealer for specific part information and ordering.

6.3.2 Internal Inspection

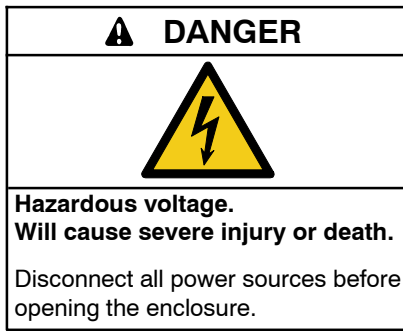

Disconnect all power sources, open the transfer switch enclosure door, and inspect internal components monthly or when any condition noticed during an external inspection may have affected internal components.

Contact an authorized distributor/dealer to inspect and service the transfer switch if any of the following conditions are found inside the transfer switch.

- Accumulations of dirt, dust, moisture, or other contaminants
- Signs of corrosion
- Worn, missing, or broken components
- Loose hardware
- Wire or cable insulation deterioration, cuts, or abrasion
- Signs of overheating or loose connections: discoloration of metal, melted plastic, or a burning odor
- Other evidence of wear, damage, deterioration, or malfunction of the transfer switch or its components.

If the application does not allow a power interruption for the time required for the internal inspection, have an authorized distributor/dealer perform the internal inspection.

6.3.3 SPD Inspection

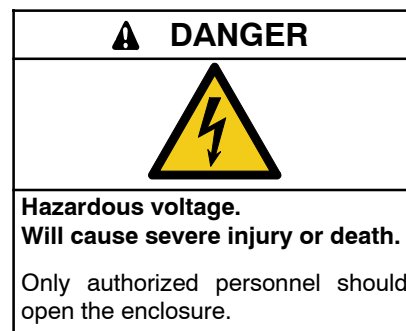

On transfer switches equipped with optional surge protective devices (SPDs), check the following items every two months:

- SPD status indicators
- Condition of SPD connecting leads

6.3.4 Other Inspections and Service

Have an authorized distributor/dealer perform scheduled maintenance, service, and other maintenance that ensures the safe and reliable operation of the transfer switch. See Section 6.4, Service Schedule, for the recommended maintenance items and service intervals.

Have an authorized distributor/dealer repair or replace damaged or worn internal components with manufacturer-recommended replacement parts.

6.4 Service Schedule

performed by an authorized distributor/dealer except for activities designated by an X, which may be performed by the switch operator.

Follow the service schedule below for the recommended service intervals. Have all service

System Component or Procedure	See Section	Visually Inspect	Check	Adjust, Repair, Replace	Clean	Test	Frequency
Electrical System							
Check for signs of overheating or loose connections: discoloration of metal, melted plastic, or a burning odor	6.3.1	X	X				Y
Check the contactor's external operating mechanism for cleanliness; clean and relubricate if dirty *	6.3.1	X			D (clean and lube)		Y
Inspect wiring insulation for deterioration, cuts, or abrasion. Repair or replace deteriorated or damaged wiring	6.3.1	X	D	D			Y
Tighten control and power wiring connections to specifications	2		D			D	Y
Check the transfer switch's main power switching contacts' condition; clean or replace the main contacts or replace the contactor assembly as necessary	S/M	D		D	D		Y
Control System							
Exercise the generator set under load	6.2.1					X	W
Test the transfer switch's automatic control system	6.2.2 1.8	X				X	M
Test all indicators (LEDs) and all remote control systems for operation	I/M	X	D	D		D	Y
General Equipment Condition							
Inspect the outside of the transfer switch for any signs of excessive vibration, leakage, high temperature, contamination, or deterioration *	6.3.1	X			X		M
Check that all external hardware is in place, tightened, and not badly worn	6.3.1	X	X	X			M
Inspect the inside of transfer switch for any signs of excessive vibration, leakage, high temperature, contamination, or deterioration *	6.3.4	D	D		D		Y
Check that all internal hardware is in place, tightened, and not badly worn	6.3.4	X	D	D			Y
SPD Modules (if equipped)							
Check status indicators	7.11	X		D			Every 2 months
Check condition of connecting leads	7.11	X		D			
* Service more frequently if the transfer switch is operated in dusty or dirty areas.							
See Section: Read these sections carefully for additional information before attempting maintenance or service.							
Visually Inspect: Examine these items visually.							
Check: Requires physical contact with or movement of system components, or the use of nonvisual indications.							
Adjust, Repair, Replace: Includes tightening hardware and lubricating the mechanism. May require replacement of components depending upon the severity of the problem.							
Clean: Remove accumulations of dirt and contaminants from external transfer switch's components or enclosure with a vacuum cleaner or by wiping with a dry cloth or brush. <i>Do not use compressed air to clean the switch because it can cause debris to lodge in the components and cause damage.</i>							
Test: May require tools, equipment, or training available only through an authorized distributor/dealer.							
Symbols used in the chart:							
X= The transfer switch operator can perform these tasks.				W=Weekly			
D=An authorized distributor/dealer must perform these tasks.				M=Monthly			
I/M = Transfer Switch Installation Manual				Q=Quarterly			
S/M = Service Manual. An authorized distributor/dealer must perform these tasks.				S=Semiannually (every six months)			
				Y=Yearly (annually)			

7.1 Introduction

This section describes the hardware options that will interface with the Decision-Maker® MPAC 1200 controls. The following accessories are available:

- Accessory modules
- Controller disconnect switch
- Current monitoring
- Digital meter: displays voltage, frequency, current, power, and more (factory-installed)
- Ethernet communication board
- Load shed module (available on programmed-transition and closed-transition models only)
- Line-to-neutral voltage monitoring
- Supervised transfer control switch
- Surge protection device (SPD)
- User interface cover

7.2 Accessory Modules

The following types of accessory modules (also referred to as accessory boards) are available:

- Standard input/output module
- High power input/output module
- Alarm module with Chicago alarm function
- External battery module

See the transfer switch Installation Manual for field connection instructions. If the modules are not factory-installed, refer to the installation instructions provided with the accessory kits.

The mounting kit holds up to five optional modules. The maximum total current draw is 300 mA. See Figure 7-1. If an External Battery Module is installed, there is no current restriction.

The accessory modules with mounting kit are shown in Figure 7-2.

Module Current Draw Specifications, mA	
Alarm Module	75
Standard I/O Module	75
High Power I/O Module	100

Figure 7-1 Option Board Types

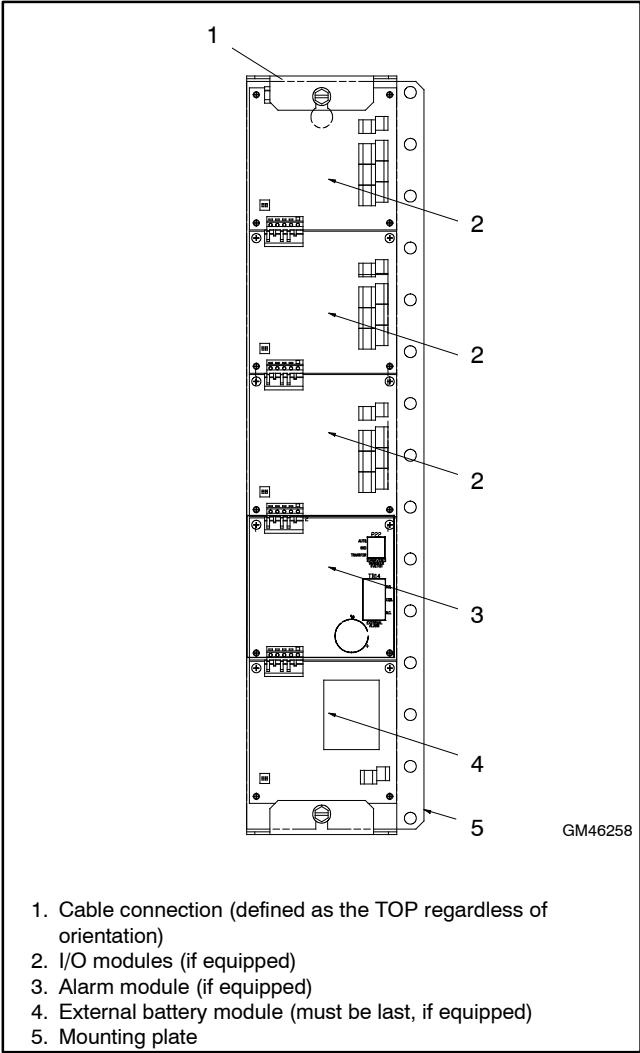

Figure 7-2 Accessory Module Mounting

7.2.1 Input/Output (I/O) Modules

Two types of input/output modules are available. The standard I/O Module has two inputs and six outputs. The high-power I/O module has two inputs and three outputs. See Figure 7-4 through Figure 7-6 for I/O module illustrations and specifications.

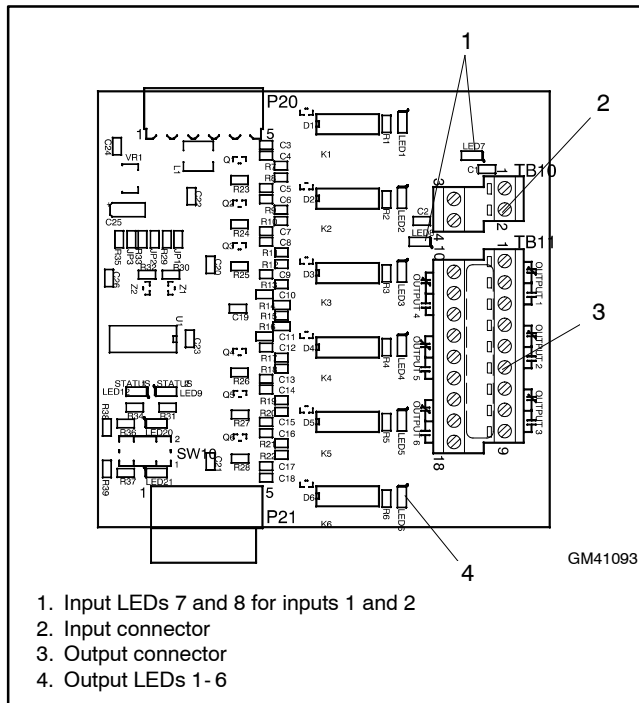

Figure 7-3 Standard I/O Module

Inputs	
Available Inputs	2
Input Definition	Contact Closure
Current	5 mA Max
Connection Type	Terminal Strip
Wire Size	#14-24 AWG
Max Distance	700 feet
Outputs	
Outputs Available	6
Contact Type	Form C (SPDT)
Contact Voltage Rating	2 A @ 30 VDC 500 mA @ 125 VAC
Connection Type	Terminal Strip
Wire Size	#14-24 AWG

Figure 7-4 Standard Input/Output Module

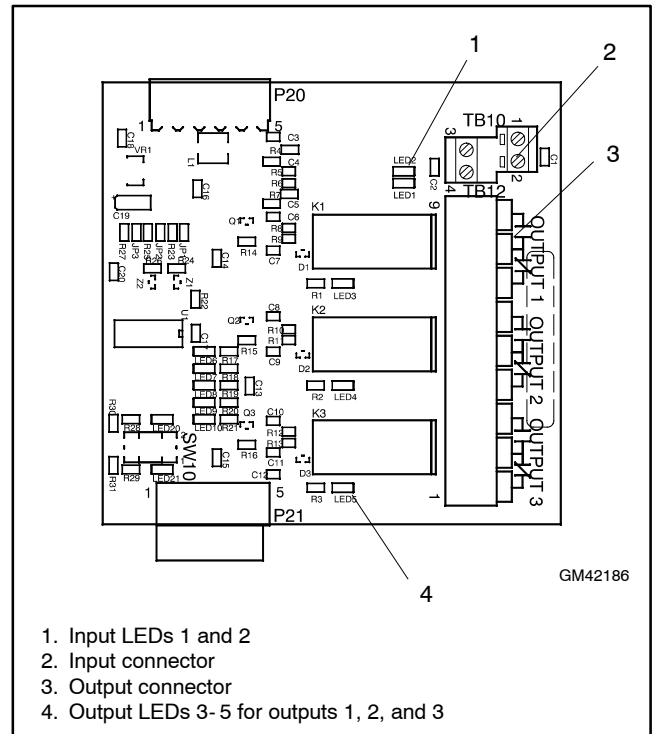

Figure 7-5 High-Power I/O Module

Inputs	
Available Inputs	2
Input Definition	Contact Closure
Current	5 mA Max
Connection Type	Terminal Strip
Wire Size	#14-24 AWG
Max Distance	700 feet
Outputs	
Outputs Available	3
Contact Type	Form C (SPDT)
Contact Voltage Rating	12 A @ 24 VDC 12 A @ 250 VAC 10 A @ 277 VAC 2 A @ 480 VAC
Connection Type	Terminal Strip
Wire Size	#14-24 AWG
Environmental Specifications	
Temperature	-40°C to 85°C (-40°F to 185°F)
Humidity	35% to 85% noncondensing

Figure 7-6 High-Power Input/Output Module

Note: Each I/O module must have unique address.

Use the address DIP switches on the I/O module to assign a unique (different) address to each module as shown in Figure 7-7. Assign addresses in order from 1 to 4. An LED for each DIP switch lights to indicate that the switch is closed.

The alarm module's fixed address is 5. The battery module's fixed address is 6.

Use the Set Inputs/Outputs menu to assign input and output functions. See Section 4.7 for instructions.

LEDs on the module circuit board light to indicate that each input or output is active.

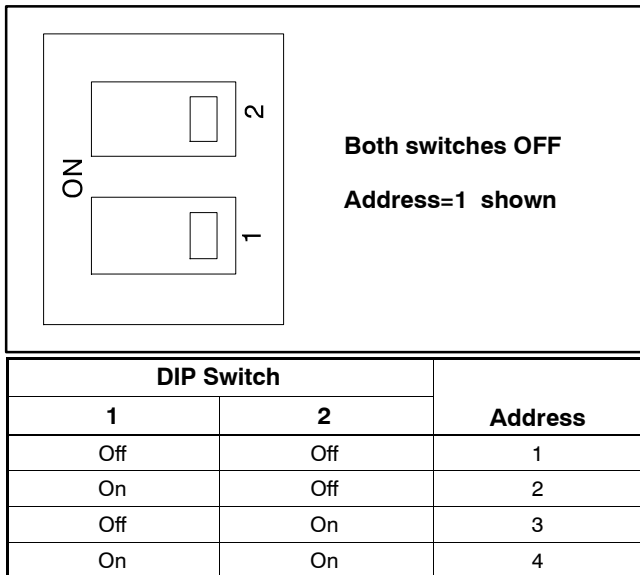

Figure 7-7 Address DIP Switch Settings

7.2.2 External Battery Supply Module (EBSM)

The external battery supply module (EBSM) kit allows connection to the generator set engine start battery(ies) or other batteries to provide 12 VDC power to the ATS controller. The EBSM may also be referred to as the battery option board (BOB).

The EBSM kit is required for the following applications:

- **Systems using extended engine start time delays.** The EBSM provides power to the ATS controller during extended time delays longer than 15 seconds, when neither the Normal nor the Emergency source is available.
- **Installations with frequent utility power outages.** The EBSM provides power to the ATS controller when neither source is available, preserving the controller's backup battery.

The EBSM produces 2 amps at 12 VDC with 9- 36 VDC input. The EBSM input is reverse-polarity protected. The EBSM outputs a low battery voltage signal when the external battery voltage falls below 11 VDC for a 12-volt system or 22 VDC for a 24-volt system.

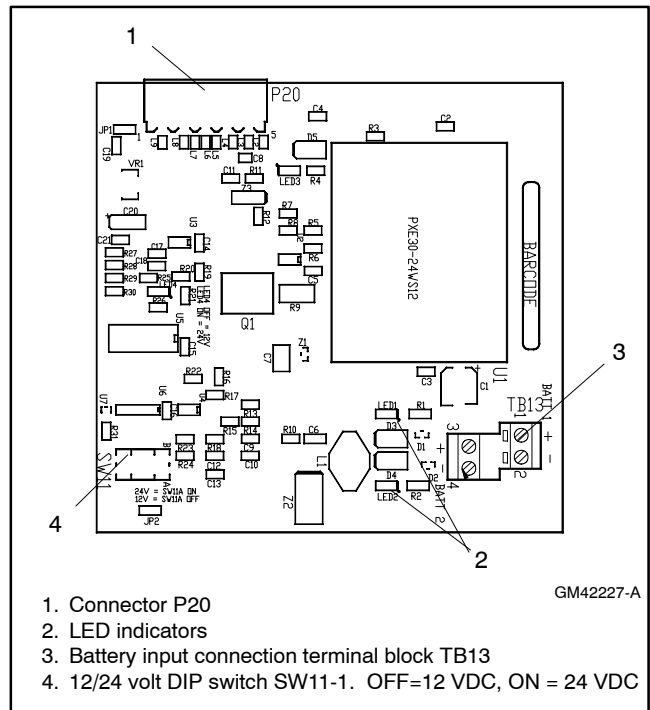

Figure 7-8 External Battery Supply Module

DIP Switch SW11-1 Setting	Battery Voltage
OFF	12 VDC
ON	24 VDC

Figure 7-9 Battery Voltage Selection

7.2.3 Alarm Module

See Figure 7-10 for the alarm module.

The functions provided by this board are:

- 90 dB Audible alarm (any alarm function can be programmed to trigger the audible alarm)
- Chicago alarm operation
- Preferred source selection
- Supervised transfer control (supervised transfer control switch required)
- Connection for external alarm

The alarm board has a fixed address = 5.

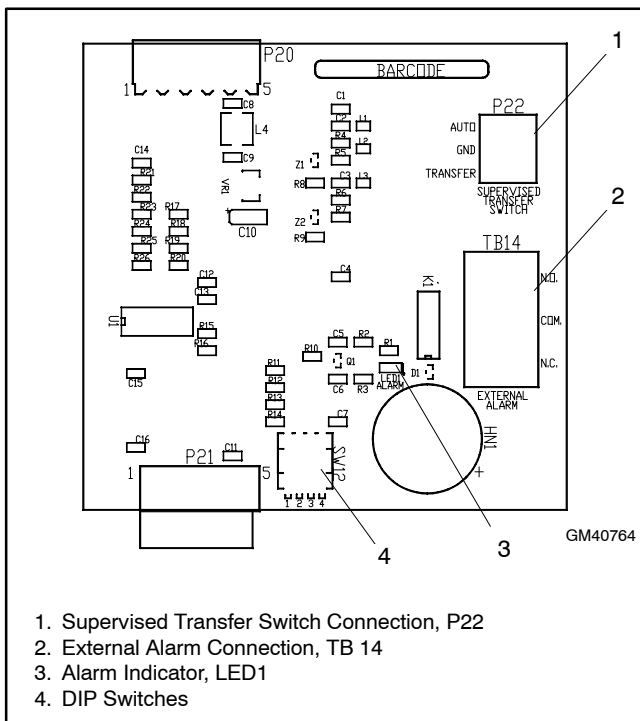

Figure 7-10 Alarm Module

Alarm Board DIP Switches

There are four DIP switches on the alarm module board. Some of the switches are not used. See Figure 7-11. To enable the preferred source selection, set DIP switch 1 to ON. If the supervised transfer switch is installed on the ATS, set DIP switch 2 to ON.

DIP Switch	Function
1	Preferred source selection
2	Supervised transfer enable
3	Not used
4	Not used

Figure 7-11 Alarm Board DIP Switches

Preferred Source Selection

The alarm module is required for preferred source selection. To enable the preferred source selection, set DIP switch 1 to ON. Then see Section 4.6.3 for instructions to select Source N or Source E as the preferred source.

External Alarm

A customer-supplied external alarm horn can be connected to the alarm module at terminal block TB14. Connect to the normally open or normally closed contact as recommended by the alarm manufacturer's instructions. See Figure 7-12.

Item	Specification
Wire Size	#12-22 AWG Cu
Contact Voltage Rating	500 mA @ 120 VAC
	250 mA @ 240 VAC

Figure 7-12 External Alarm Connection Specifications

Audible Alarm Setup

The alarm board is equipped with a 90 dB audible alarm. The audible alarm can be set to sound under selected fault conditions. Use the Common Alarms Setup menu to assign functions to the audible alarm. See Section 4.8 for instructions to set Audible Alarm: Y for each function that should trigger the alarm.

Alarm Operation, Normal Mode

In Normal Mode, the horn sounds anytime a fault event happens in the system. The horn continues to sound unless the alarm silence button is pressed. When the fault is cleared, the alarm silence is ended and reset for the next alarm.

Alarm Operation, Chicago Alarm Mode

Chicago Alarm mode requires the horn to sound and a lamp or LED to light when the switch is in the emergency (non-preferred) position. The horn continues to sound unless the alarm silence button is pressed. When the fault is cleared, the alarm silence is ended and reset for the next alarm.

For Chicago Alarm Mode, use the Common Alarm Setup menu to assign the necessary faults and conditions to the audible alarm. See Section 4.8. Be sure to assign the Contactor in Standby condition to trigger the audible alarm.

A remote alarm or indicator light can also be connected to the alarm board to indicate the alarm condition as described previously. See External Alarm.

Alarm Silence Mode

In Alarm Silence Mode, the horn is disabled. Alarm Silenced appears on the display and the system alert LED lights.

The Alarm Silenced condition can be assigned to a programmable output. See Section 4.7 for instructions to assign outputs.

Instructions to Silence the Alarm in Normal and Chicago Alarm Modes

When the alarm is activated, the word Alarm appears on the main display menu above the first button. See Figure 7-13. Press the Alarm button to open the Reset menu. Then press the button labeled Reset to silence the alarm.

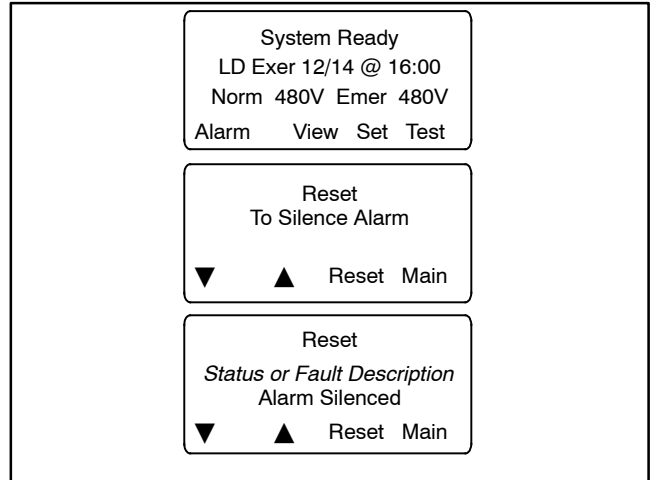
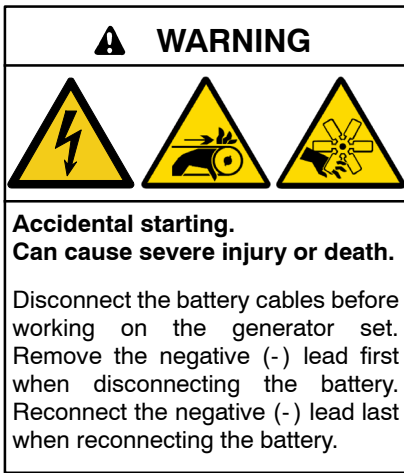
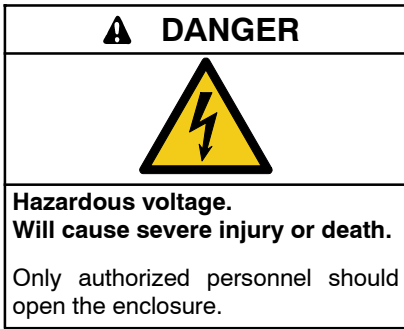

Figure 7-13 Alarm Silence

7.3 Controller Disconnect Switch



Disabling the generator set. Accidental starting can cause severe injury or death. Before working on the generator set or equipment connected to the set, disable the generator set as follows: (1) Press the generator set off/reset button to shut down the generator set. (2) Disconnect the power to the battery charger, if equipped. (3) Remove the battery cables, negative (-) lead first. Reconnect the negative (-) lead last when reconnecting the battery. Follow these precautions to prevent the starting of the generator set by the remote start/stop switch.



The controller disconnect switch allows disconnection of the power to the controller during maintenance and service. See Figure 7-14.

Note: Disable the generator set before using the controller disconnect switch to disconnect power to the ATS controls.

Disconnecting power to the controls will cause the ATS to send an engine start signal to the generator set. Prevent the generator set from starting by pressing the OFF button on the generator set controller and disconnecting the battery charger and battery. Refer to the generator set operation manual for specific instructions.

The switch has two positions, auto (I) and disconnect (0). Move the controller disconnect switch to the 0 position to disconnect power to the ATS controller. After maintenance or service, move the switch to the I position to reconnect power. Follow the instructions in the generator set documentation to reenble the generator set.

The controller disconnect switch is not available for service entrance models, which are equipped with a control circuit isolation switch as standard equipment.

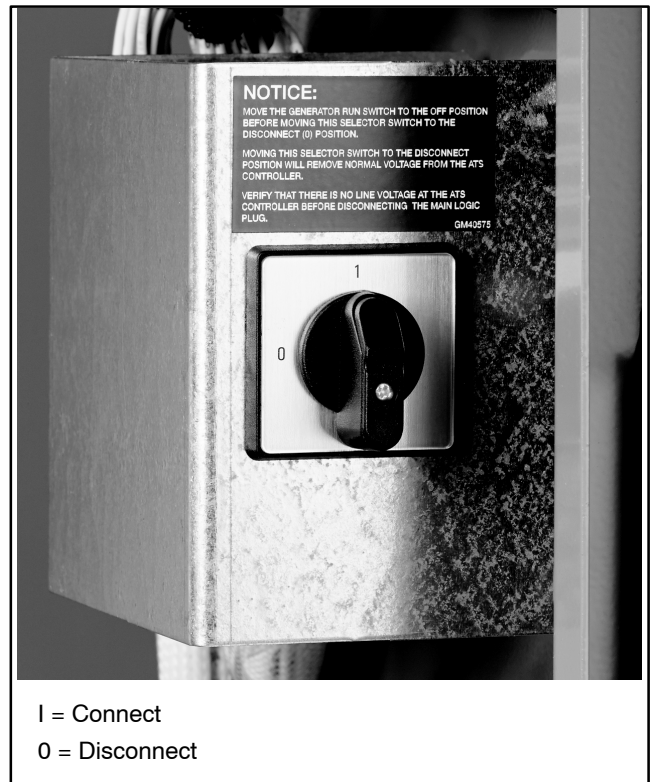

Figure 7-14 Controller Disconnect Switch

7.4 Current Sensing

The current sensing kit is shown in Figure 7-15. See Figure 7-16 for the current sensing kit connections.

The current sensing kit uses current transformers to measure the load bus current on all phases. Load current can then be displayed on the controller menu. See Section 1.6, Normal Operation Menus.

Current transformer kits are designed for your transfer switch based on the current rating, number of phases, and transfer switch model.

Use a clamp-on current sensing meter to calibrate the current. Store the measured current values using the Calibration menu. See Section 4.12.

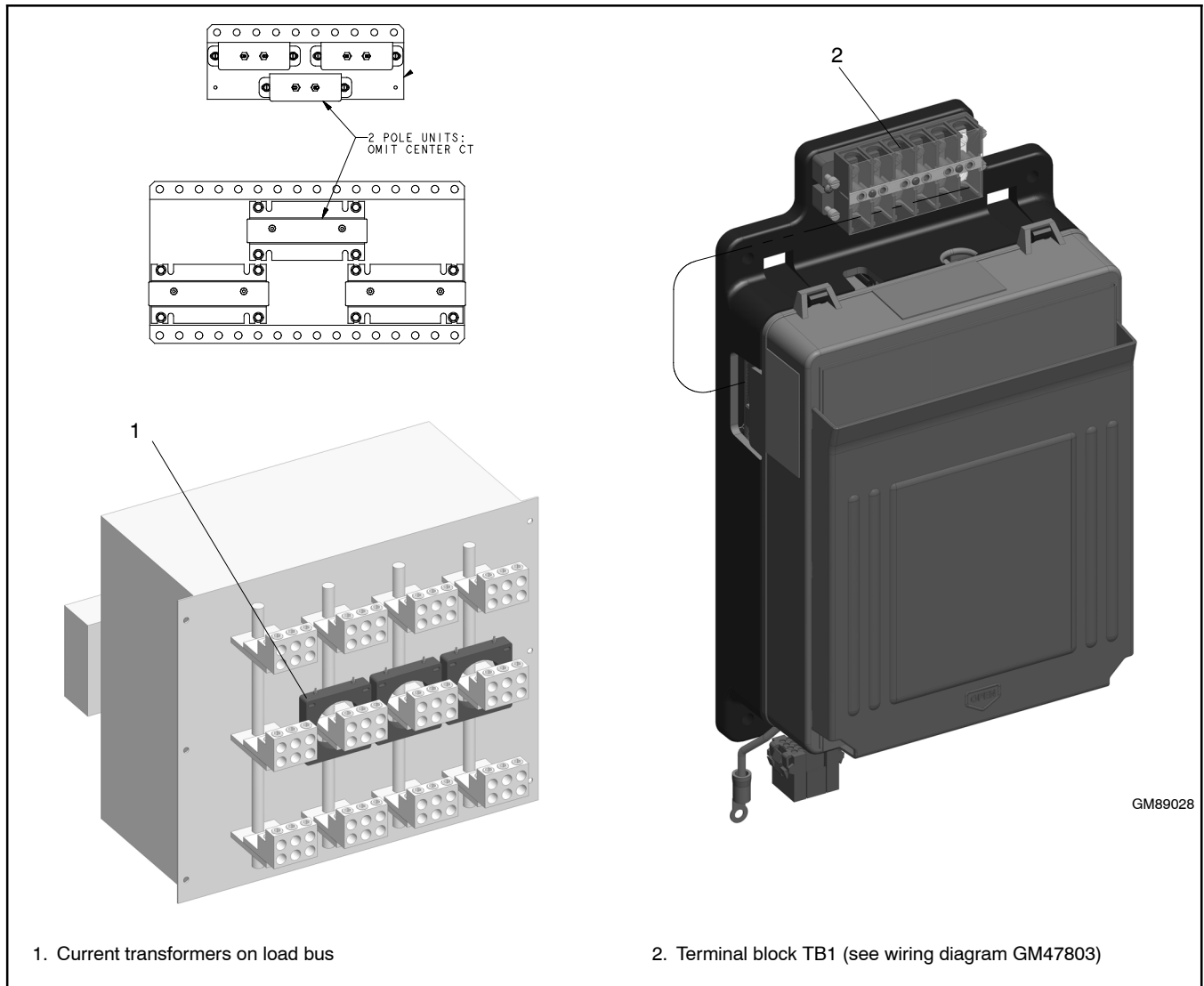

Figure 7-15 Current Sensing Kit

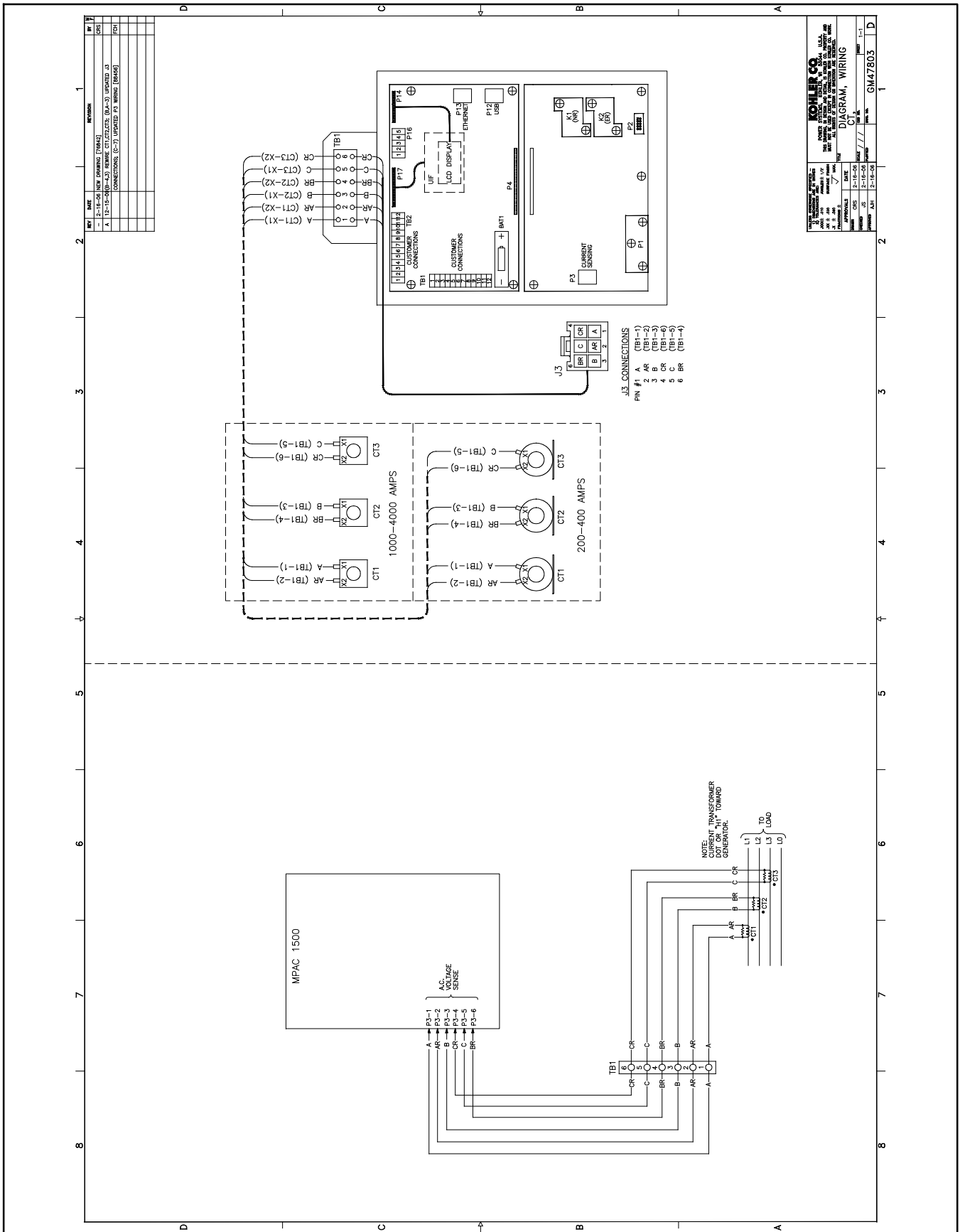

Figure 7-16 Current Sensing Wiring Diagram

7.5 Digital Meter

The digital power meter displays voltage, current, frequency, and power. See Figure 7-17 for a typical meter display. Other features include:

- 35 programmable alarms
- LCD display, 67 x 62.5 mm (2.65 x 2.5 in.)
- Pushbutton operation
- Password-protected programming menus
- Two digital inputs
- Two digital outputs
- Two Form A relay outputs
- Serial port for optional network connections
- Data logging

Digital meters must be factory-installed.

See TP- 7168, PM5330 User Manual, for operation instructions.



Figure 7-17 Digital Meter

7.6 Ethernet Communication Board

Ethernet communication is provided by a circuit board that connects to the MPAC controller board. The Ethernet communication board is optional for the MPAC 1200 controller. The Ethernet board includes an RJ-45 connector for an Ethernet cable.

The Ethernet board may have a default IP address assigned at the factory for test purposes. **Change the IP address to an address owned by the user.** Assign a new IP address and port number from the controller's user interface or use a personal computer and Kohler SiteTech software.

See Section 5.2.3 for more information about Ethernet communications.

7.7 Heater

An anti-condensation heater kit is available. The strip heater is controlled by a hygrostat to raise the temperature inside the enclosure above the dew point to prevent condensation. Figure 7-18 shows a typical location of the heater kit components inside the enclosure.

The installer must connect 120 VAC power to the terminal block near the hygrostat. See Figure 7-19 and Figure 7-20. The heater and hygrostat are connected to power through a 15-amp circuit breaker.

The relative humidity setting on the hygrostat is adjustable from 35% to 95%. A setting of 65% is recommended.

Because of space limitations in the smaller enclosures, the following models can include either an enclosure heater or a surge protection device (SPD), but not both:

- Model KCS 30- 200 Amps
- Model KSS/KSSB 40- 225 Amps

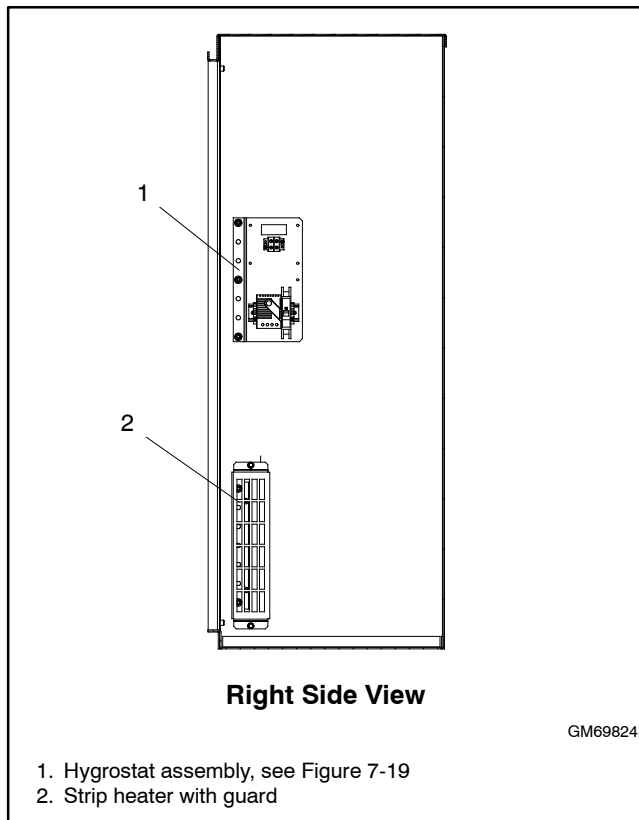

Figure 7-18 Heater Location, Typical

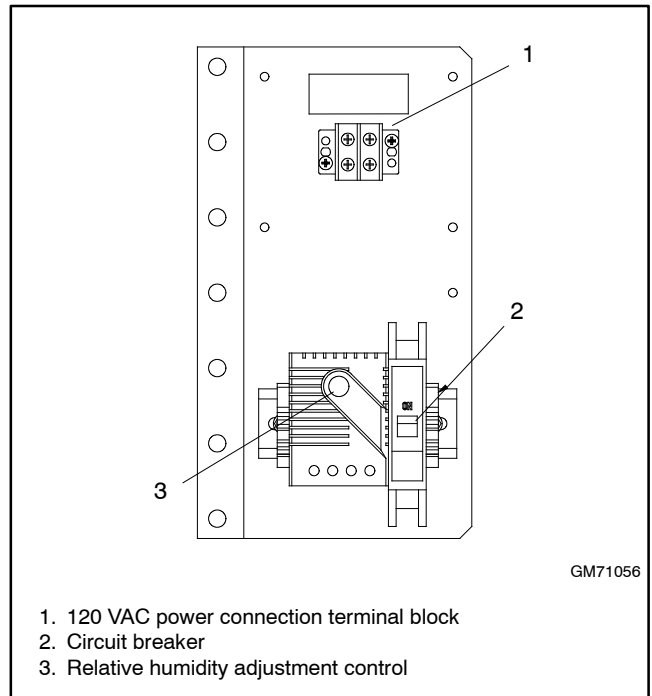

Figure 7-19 Hygrostat Assembly, Typical

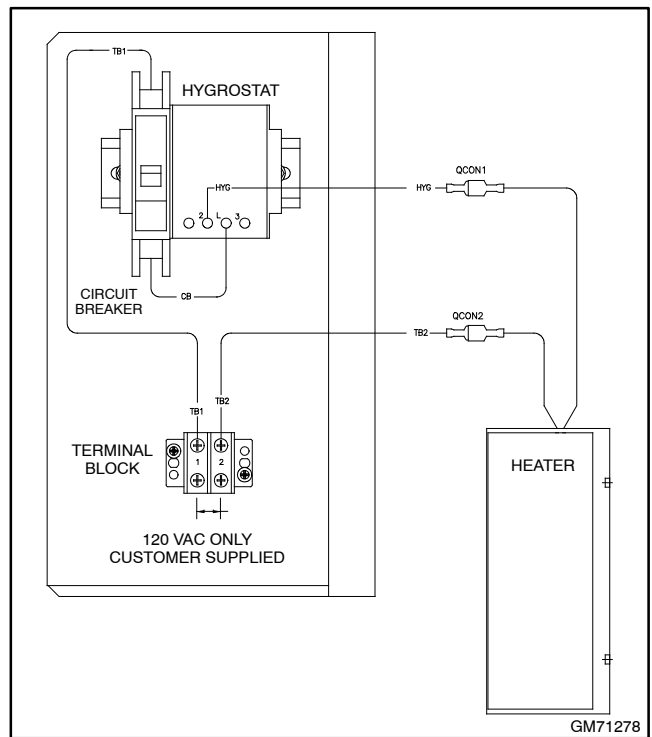

Figure 7-20 Heater Connections

7.8 Line-to-Neutral Voltage Monitoring

Line-to-neutral voltage monitoring allows the display of the AN, BN, and CN RMS voltages in the normal operation menus. See Section 1.6. It is standard on 4-pole models and optional on 2-pole and 3-pole models.

The line-to-neutral monitoring kit is available factory-installed or as a loose kit. Refer to the instructions provided with the kit for field installation.

7.9 Load Shed (Forced Transfer to OFF)

The load shed (forced transfer to OFF) accessory is available for programmed-transition and closed-transition transfer switches.

- The load shed accessory for models KCP and KCC is available factory-installed or as a loose kit.
- The load shed accessory for bypass/isolation models KBP and KBC must be factory-installed.
- The load shed accessory is not required for load shed (forced transfer to OFF) functionality on model KEP Service Disconnect to OFF models.

See Figure 7-21 for an illustration of the load shed accessory.

7.9.1 Description

The load shed (forced transfer to off) accessory allows the removal of non-critical loads from the Source E generator set. The accessory requires an external signal (contact closure) to initiate transfer to the OFF position.

When the Forced Transfer to Off input is activated (contact closed), the contactor moves from Source E to the OFF position immediately, ignoring all time delays. If the normal source is available when the input is activated, the ATS transfers to the OFF position and then to Source N. If Source N is not available, the ATS remains in the OFF position until the input is deactivated.

Activating the Forced Transfer to Off input while the contactor is in the Source N position does not cause a transfer to the OFF position. However, if source N is lost while the input is activated, the contactor will move to the

OFF position. The contactor will not transfer to Source E, even if Source E is available. When Source N returns, the contactor will transfer back to Source N.

When the input is deactivated, the ATS transfers back to Source N, if available, executing all programmed time delays. If Source N is not available, the ATS transfers to Source E.

The load shed (forced transfer to off) function only sheds loads connected to Source E. The preferred source selector switch position (if equipped) does not affect this function.

7.9.2 Customer Connection

The load shed function requires an external signal (contact closure) to initiate transfer to the OFF position. Connect the external contact to input #1 (if available) or input #2 on connector TB1 on the controller. See Figure 7-22. Use #12-24 AWG wire and tighten to 0.5 Nm (4.4 in. lb.).

Use the Set Inputs/Outputs menu or Kohler® SiteTech™ software to assign the connected input (Main Board Input #1 or #2, or Digital Input A1 or A2 in SiteTech) to the Forced Transfer to Off function. If the external contact is connected to a different input connection on an optional I/O module, assign the Forced Transfer to Off function to that input.

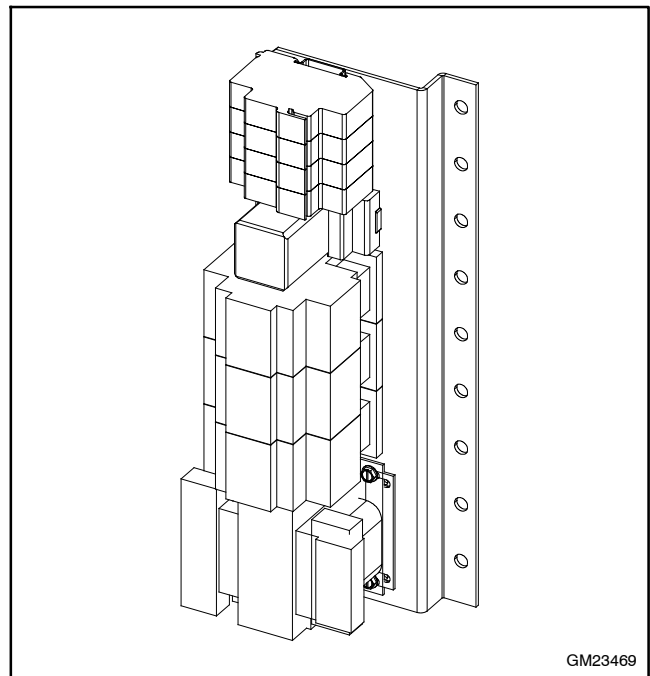

Figure 7-21 Load Shed Accessory (for identification)

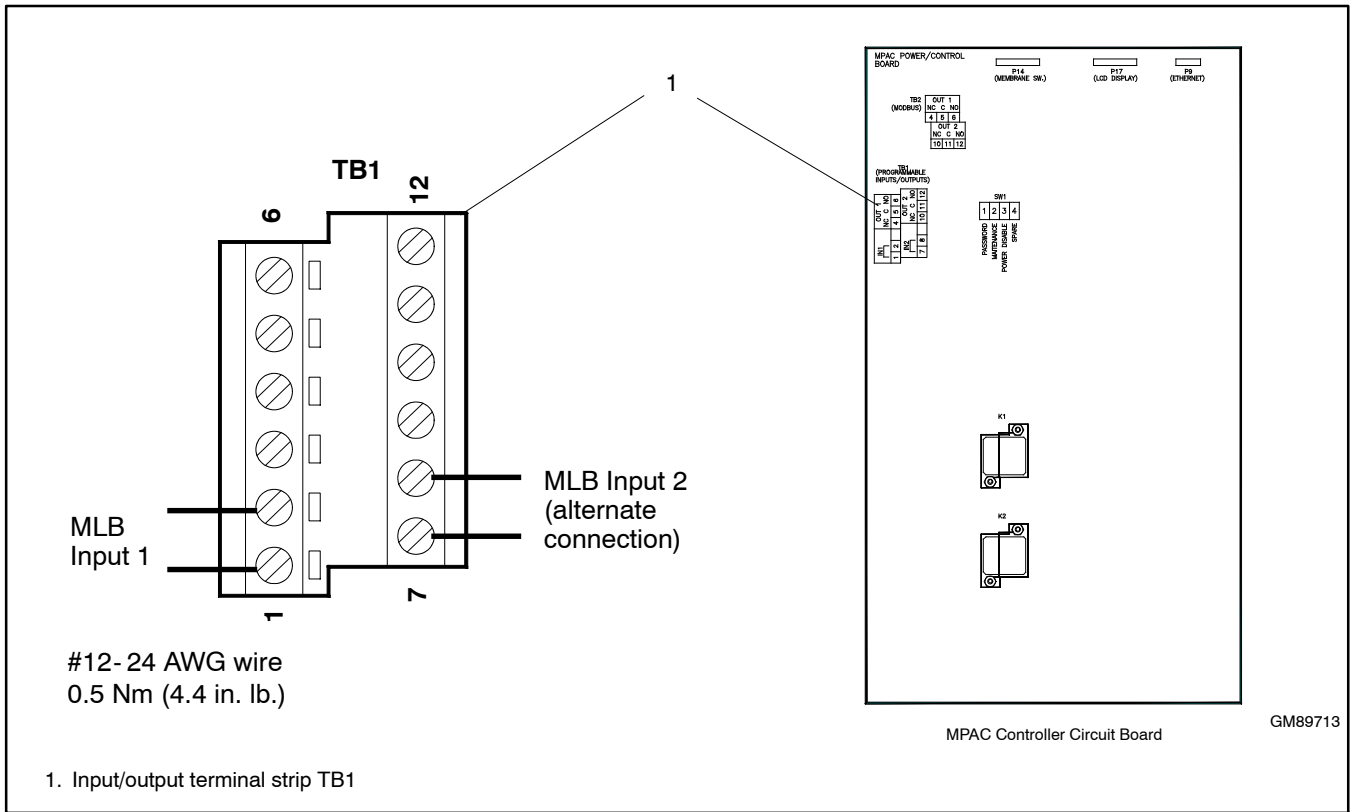

Figure 7-22 Forced Transfer to Off Input Connection (for load shed kits)

7.10 Supervised Transfer Control Switch

The supervised transfer control switch (AUTO/MANUAL/TRANSFER switch) is a three-position, key-operated switch that allows manual control of load transfers. The alarm module is required for installation and operation of the supervised transfer control switch. The switch connects to P22 on the alarm module. See Figure 7-10.

The switch has maintained AUTO and MANUAL positions and a momentary TRANSFER position. The key can be removed in either the AUTO or MANUAL position. The key cannot be removed when the switch is in the TRANSFER position. Figure 7-23 shows the switch.

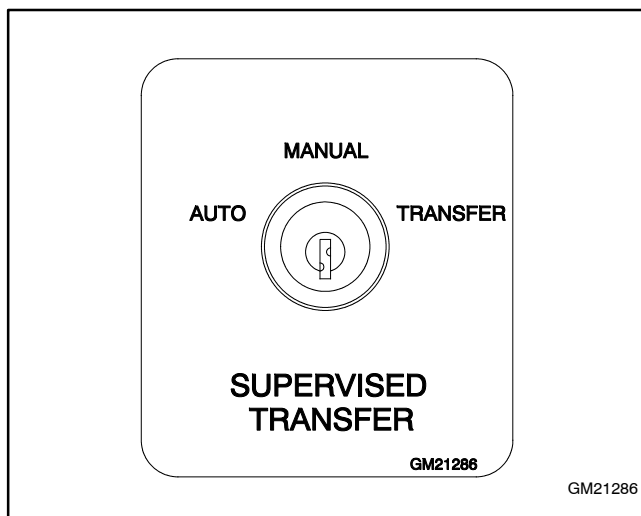

Figure 7-23 Supervised Transfer Control Switch

7.10.1 Manual Transfer

Moving the switch to the TRANSFER position will not cause the ATS to transfer unless an event such as a loss of utility, a loaded test, or a loaded exercise has initiated a transfer sequence. The transfer sequence executes all programmed time delays and signals the generator set engine to start. Wait for the time delays to expire, or press the End Time Delay button.

MANUAL TRANSFER is displayed on the controller display and the Not-in-Auto LED flashes when the ATS is ready to transfer. Turn the switch to TRANSFER and release it to allow a transfer. It is not necessary to hold the switch in the TRANSFER position.

The MANUAL mode allows the system to run on the standby source indefinitely, even if the preferred source is available.

Manual Transfer Procedure

1. An event occurs such as the loss of the connected source or the start of a loaded exercise, or an operator starts a loaded test.
2. The ATS executes times delays and signals the generator set engine to start.

Note: Press the END TIME DELAY button to shorten the time delays, if desired.

3. MANUAL TRANSFER is displayed on the controller and the Not-in-Auto LED flashes.
4. Turn the keyswitch to the TRANSFER position and release.
5. The load is transferred to the standby source, if available.
6. When the preferred source returns or the exercise or test ends, manual transfer is required to transfer back to the preferred source. Turn the keyswitch to TRANSFER and release. Load control time delays will operate if both sources are available.

Note: Automatic and non-automatic transfer switches operate differently when the supervised transfer control switch is in the MANUAL position. The operation is described in the following sections and shown in Figure 7-24.

7.10.2 Automatic Transfer Switches

AUTO position

On an automatic transfer switch, when the Supervised Transfer Control switch is in the AUTO position, the controller responds normally to transfer requests, and will automatically transfer to a source if that source is available.

MANUAL Position

On an automatic transfer switch with the Supervised Transfer Control Switch in the MANUAL Position, the contactor will automatically transfer to the available source if the connected source is not available. In this case, no user action is required to initiate the transfer.

Operation with Test and Peak Shave

On an automatic transfer switch, a test, peak shave, or loaded exercise command will be recognized and a transfer sequence to the standby source will operate normally when the Supervised Transfer Control Switch

is in the MANUAL position. However, ending the test or removing the peak shave signal will *not* cause a transfer back to the preferred source. Move the supervised transfer control switch to the TRANSFER position to initiate transfer back to the preferred source.

7.10.3 Non-Automatic Transfer Switches

Non-automatic transfer switches are factory-equipped with the supervised transfer control switch.

Note: Transfer switches are built and UL-labeled as automatic or non-automatic by the factory and cannot be converted in the field. The supervised transfer control switch must not be removed from non-automatic switches in the field.

AUTO position

On a non-automatic transfer switch, when the Supervised Transfer Control switch is in the AUTO

position, the controller responds normally to transfer requests, and will automatically transfer to a source if that source is available.

MANUAL Position

When the supervised transfer control switch is in the MANUAL position, a non-automatic transfer switch does not transfer automatically, even if the connected source is lost. To initiate a transfer sequence after the source has been lost, move the switch to TRANSFER and then release the switch as described in Section 7.10.1.

Operation with Test and Peak Shave

On a non-automatic transfer switch, the test, peak shave and loaded exercise signals are ignored when the Supervised Transfer Control Switch is in the MANUAL position.

Switch Position	Automatic Switches	Non-Automatic Switches
AUTO	<ul style="list-style-type: none"> Automatically transfers to the standby source, when available, if the preferred source is lost. Transfers back to the preferred source when it becomes available. 	
MANUAL	<ul style="list-style-type: none"> Automatically transfers to an available source if the connected source is lost. Test, peak shave, and loaded exercise commands will transfer to the standby source. Does not automatically transfer back to preferred when both sources are available. 	<ul style="list-style-type: none"> Does not automatically transfer to an available source when the connected source is lost. Test, peak shave, and loaded exercise commands are ignored. Does not automatically transfer back to preferred when both sources are available. Transfers only when the switch is manually moved to the TRANSFER position as described below.
TRANSFER (momentary switch position)	<ul style="list-style-type: none"> Does not initiate an engine start sequence. Generator set engine must be signalled to start by an event such as a loss of utility, loaded test, loaded exercise, etc. Allows transfer to the other source, if available. An event such as a loss of utility, loaded exercise, or loaded test must first initiate the transfer sequence. Time delays will operate. Wait for time delays to expire, or press the End Time Delay button. Operates pre- and post-transfer load control time delays if both sources are available. MANUAL TRANSFER is displayed when the ATS is ready to transfer. 	

Figure 7-24 Supervised Transfer Control Switch Operation for Automatic and Non-Automatic Transfer Switches

7.11 Surge Protection (SPD)

A surge protection device (SPD) is available for the transfer switch. Installed on the Normal source side, the SPD protects the system from voltage surges, preventing damage to household loads. The SPD resets automatically. See Figure 7-25 for the typical SPD assembly location inside the ATS enclosure. See Figure 7-26 for SPD specifications and Figure 7-27 for SPD connections.

Because of space limitations in the smaller enclosures, the following models can include either an enclosure heater or a surge protection device (SPD), but not both:

- Model KCS 30- 200 Amps
- Model KSS/KSSB 40- 225 Amps

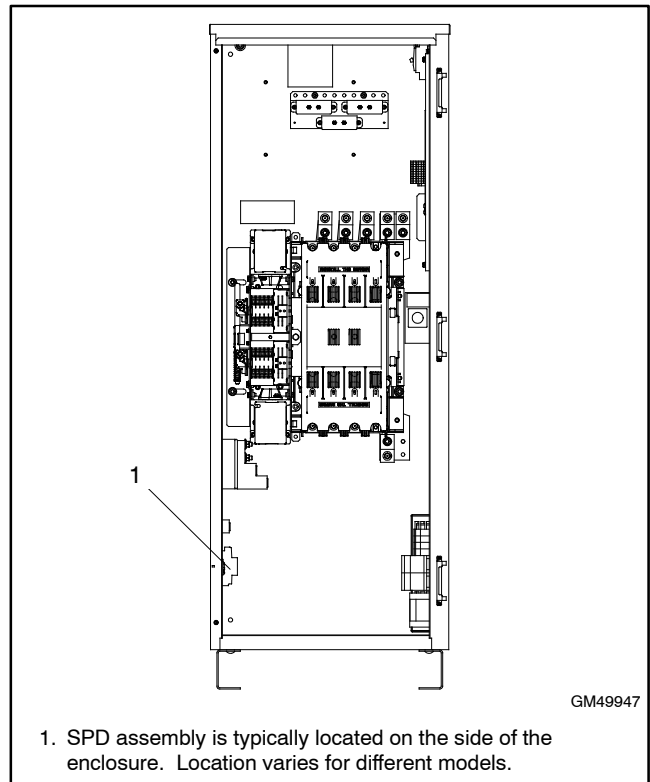

Figure 7-25 SPD Location, Typical

SPD Specifications								
Nominal Voltage (V ± 15%)	Max. Discharge Current (kA)	Phase	Poles	UL VPR 3rd Ed (L-N/N-G/L-G) (kV)	Limiting Voltage, (L-N/N-G/L-G) (kV)		Short Circuit Withstand Current (kA)	Maximum Continuous Operating Voltage (VAC)
					at 3kAmps	at 10kAmp		
120/240	40	Split	3	0.6 / 1.2 / 0.7	0.6 / 0.4 / 0.6	0.8 / 0.7 / 0.8	200	175 / 350
120/208	40	Wye	4	0.6 / 1.2 / 0.7	0.6 / 0.4 / 0.6	0.8 / 0.7 / 0.8	200	175 / 350
277/480	40	Wye	4	1.0 / 1.2 / 1.1	1.0 / 0.4 / 1.0	1.2 / 0.7 / 1.2	200	320 / 640
120/240	40	HLD	4	1.0 / 1.2 / 1.1	1.0 / 0.4 / 1.0	1.2 / 0.7 / 1.2	200	320 / 640
347/600	40	Wye	4	1.3 / 1.2 / 1.4	1.3 / 0.4 / 1.3	1.5 / 0.7 / 1.5	200	440 / 880

Figure 7-26 SPD Specifications

7.11.1 SPD Status Indicators

A status indicator on each Surge Protection Device (SPD) module indicates the SPD condition. See Figure 7-28. A green indicator shows that the SPD is providing protection. When the status indicator is red, the SPD no longer provides protection. Replace the SPD cartridge. See Section 7.11.3 for replacement instructions.

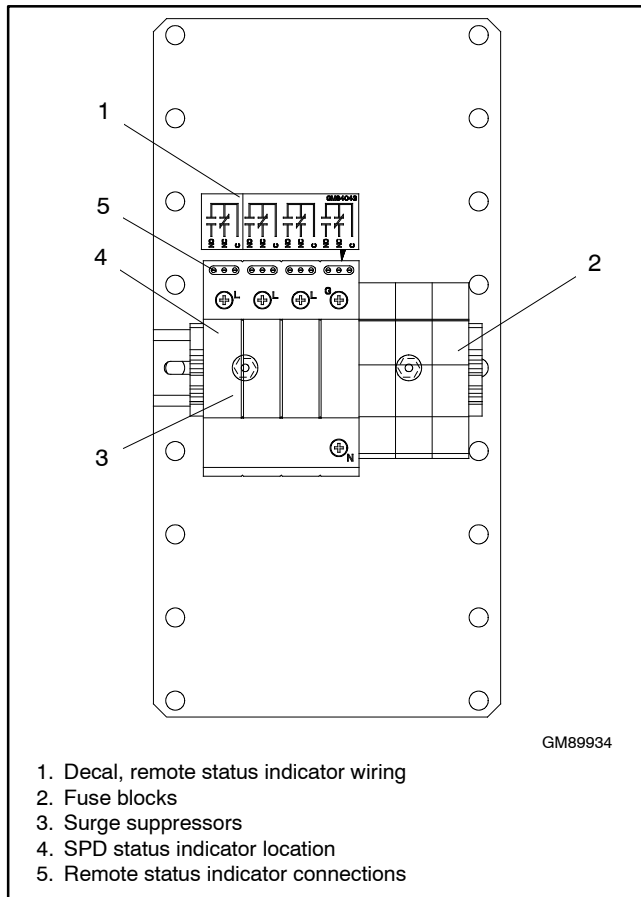

Figure 7-28 SPD Assembly, Typical

7.11.2 SPD Remote Status Indicator

A customer-supplied indicator for the SPD can be connected to provide remote indication when the SPD needs to be replaced. The contact changes state when the SPD module needs replacement.

Connect customer-provided indicators or alarms to the normally open (NO) or normally closed (NC) auxiliary contact terminals on the remote status indicator connection terminal block. See Figure 7-29 for the contact rating and Figure 7-28 for the terminal block location. See the decal on the SPD assembly or the transfer switch wiring diagram for connections.

SPD Remote Status Indication	Specification
Contact rating	1 A @ 250 VAC
Wire Size	16 AWG

Figure 7-29 Remote Status Indicator Contact Specifications

7.11.3 SPD Replacement

Replace the module when the SPD indicator turns red. Follow the replacement procedure in this section.

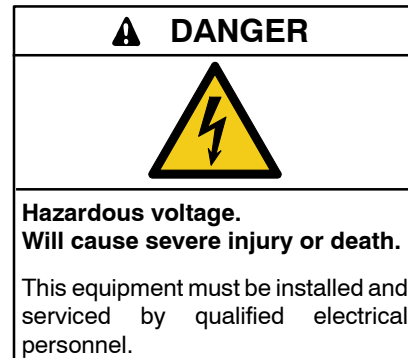

Servicing the transfer switch. Hazardous voltage will cause severe injury or death. Deenergize all power sources before servicing. Turn off the main circuit breakers of all transfer switch power sources and disable all generator sets as follows: (1) Move all generator set master controller switches to the OFF position. (2) Disconnect power to all battery chargers. (3) Disconnect all battery cables, negative (-) leads first. Reconnect negative (-) leads last when reconnecting the battery cables after servicing. Follow these precautions to prevent the starting of generator sets by an automatic transfer switch, remote start/stop switch, or engine start command from a remote computer. Before servicing any components inside the enclosure: (1) Remove all jewelry. (2) Stand on a dry, approved electrically insulated mat. (3) Test circuits with a voltmeter to verify that they are deenergized.

SPD Replacement Procedure

Note: The cartridges are keyed for the phases or the neutral. Be sure to obtain the correct service part for each cartridge. See the transfer switch parts catalog for service part numbers.

1. Disable the generator set to prevent starting as follows:
 - a. Move the generator set master switch to the OFF position.
 - b. Disconnect power to the battery charger.
 - c. Disconnect the generator set engine starting battery, negative (-) lead first.
2. Disconnect power to the transfer switch: Open the normal and emergency source circuit breakers upstream of the transfer switch.
3. Remove the enclosure's inner panel , if equipped.
4. Open the fuse holder.
5. Remove the cartridge by pulling straight out.
6. Replace the SPD cartridge with the appropriate service part.
7. Close the fuse holder.

8. Replace the enclosure's inner panel, if equipped.
9. Reconnect power to the transfer switch by closing the normal and emergency source circuit breakers.
10. Check the SPD status indicators.
11. Reconnect the generator set engine starting battery, negative (-) lead last.
12. Reconnect power to the battery charger.
13. Close and lock the ATS enclosure door.
14. Move the generator set master switch to the AUTO position.

7.12 User Interface Cover

The gasket-sealed, hinged user interface cover prevents unauthorized access to the transfer switch controls and protects the user interface from harsh environmental conditions. Use a customer-supplied padlock to lock the cover.

The cover is available as an optional accessory for NEMA 1 enclosures. NEMA 3R enclosures include the cover as standard equipment.

Appendix A Abbreviations

The following list contains abbreviations that may appear in this publication.

A, amp	ampere	cfm	cubic feet per minute	exh.	exhaust
ABDC	after bottom dead center	CG	center of gravity	ext.	external
AC	alternating current	CID	cubic inch displacement	F	Fahrenheit, female
A/D	analog to digital	CL	centerline	FHM	flat head machine (screw)
ADC	advanced digital control; analog to digital converter	cm	centimeter	fl. oz.	fluid ounce
adj.	adjust, adjustment	CMOS	complementary metal oxide substrate (semiconductor)	flex.	flexible
ADV	advertising dimensional drawing	com	communications (port)	freq.	frequency
Ah	amp-hour	coml	commercial	FS	full scale
AHWT	anticipatory high water temperature	Coml/Rec	Commercial/Recreational connection	ft.	foot, feet
AISI	American Iron and Steel Institute	conn.	connection	ft. lb.	foot pounds (torque)
ALOP	anticipatory low oil pressure	cont.	continued	ft./min.	feet per minute
alt.	alternator	CPVC	chlorinated polyvinyl chloride	ftp	file transfer protocol
Al	aluminum	crit.	critical	g	gram
ANSI	American National Standards Institute (formerly American Standards Association, ASA)	CSA	Canadian Standards Association	ga.	gauge (meters, wire size)
AO	anticipatory only	CT	current transformer	gal.	gallon
APDC	Air Pollution Control District	Cu	copper	gen.	generator
API	American Petroleum Institute	cUL	Canadian Underwriter's Laboratories	genset	generator set
approx.	approximate, approximately	CUL	Canadian Underwriter's Laboratories	GFI	ground fault interrupter
APU	Auxiliary Power Unit	cu. in.	cubic inch	GND, ⊕	ground
AQMD	Air Quality Management District	cw.	clockwise	gov.	governor
AR	as required, as requested	CWC	city water-cooled	gph	gallons per hour
AS	as supplied, as stated, as suggested	cyl.	cylinder	gpm	gallons per minute
ASE	American Society of Engineers	D/A	digital to analog	gr.	grade, gross
ASME	American Society of Mechanical Engineers	DAC	digital to analog converter	GRD	equipment ground
assy.	assembly	dB	decibel	gr. wt.	gross weight
ASTM	American Society for Testing Materials	dB(A)	decibel (A weighted)	H x W x D	height by width by depth
ATDC	after top dead center	DC	direct current	HC	hex cap
ATS	automatic transfer switch	DCR	direct current resistance	HCHT	high cylinder head temperature
auto.	automatic	deg., °	degree	HD	heavy duty
aux.	auxiliary	dept.	department	HET	high exhaust temp., high engine temp.
avg.	average	dia.	diameter	hex	hexagon
AVR	automatic voltage regulator	DI/EO	dual inlet/end outlet	Hg	mercury (element)
AWG	American Wire Gauge	DIN	Deutsches Institut für Normung e. V. (also Deutsche Industrie Normenausschuss)	HH	hex head
AWM	appliance wiring material	DIP	dual inline package	HHC	hex head cap
bat.	battery	DPDT	double-pole, double-throw	HP	horsepower
BBDC	before bottom dead center	DPST	double-pole, single-throw	hr.	hour
BC	battery charger, battery charging	DS	disconnect switch	HS	heat shrink
BCA	battery charging alternator	DVR	digital voltage regulator	hsg.	housing
BCI	Battery Council International	E ² PROM, EEPROM	electrically-erasable programmable read-only memory	HVAC	heating, ventilation, and air conditioning
BDC	before dead center	E, emer.	emergency (power source)	HWT	high water temperature
BHP	brake horsepower	ECM	electronic control module, engine control module	Hz	hertz (cycles per second)
blk.	black (paint color), block (engine)	EDI	electronic data interchange	IBC	International Building Code
blk. htr.	block heater	EFR	emergency frequency relay	IC	integrated circuit
BMEP	brake mean effective pressure	e.g.	for example (<i>exempli gratia</i>)	ID	inside diameter, identification
bps	bits per second	EG	electronic governor	IEC	International Electrotechnical Commission
br.	brass	EGSA	Electrical Generating Systems Association	IEEE	Institute of Electrical and Electronics Engineers
BTDC	before top dead center	EIA	Electronic Industries Association	IMS	improved motor starting
Btu	British thermal unit	EI/EO	end inlet/end outlet	in.	inch
Btu/min.	British thermal units per minute	EMI	electromagnetic interference	in. H ₂ O	inches of water
C	Celsius, centigrade	emiss.	emission	in. Hg	inches of mercury
cal.	calorie	eng.	engine	in. lb.	inch pounds
CAN	controller area network	EPA	Environmental Protection Agency	Inc.	incorporated
CARB	California Air Resources Board	EPS	emergency power system	ind.	industrial
CAT5	Category 5 (network cable)	ER	emergency relay	int.	internal
CB	circuit breaker	ES	engineering special, engineered special	int./ext.	internal/external
CC	crank cycle	ESD	electrostatic discharge	I/O	input/output
cc	cubic centimeter	est.	estimated	IP	internet protocol
CCA	cold cranking amps	E-Stop	emergency stop	ISO	International Organization for Standardization
ccw.	counterclockwise	etc.	et cetera (and so forth)	J	joule
CEC	Canadian Electrical Code			JIS	Japanese Industry Standard
cert.	certificate, certification, certified			k	kilo (1000)
cfh	cubic feet per hour			K	kelvin
				kA	kiloampere
				KB	kilobyte (2 ¹⁰ bytes)
				KBus	Kohler communication protocol
				kg	kilogram

kg/cm ²	kilograms per square centimeter	NBS	National Bureau of Standards	RTU	remote terminal unit
kgm	kilogram-meter	NC	normally closed	RTV	room temperature vulcanization
kg/m ³	kilograms per cubic meter	NEC	National Electrical Code	RW	read/write
kHz	kilohertz	NEMA	National Electrical Manufacturers Association	SAE	Society of Automotive Engineers
kJ	kilojoule	NFPA	National Fire Protection Association	scfm	standard cubic feet per minute
km	kilometer	Nm	newton meter	SCR	silicon controlled rectifier
kOhm, kΩ	kilo-ohm	NO	normally open	s, sec.	second
kPa	kilopascal	no., nos.	number, numbers	SI	<i>Système international d'unites</i> , International System of Units
kph	kilometers per hour	NPS	National Pipe, Straight	SI/EO	side in/end out
kV	kilovolt	NPSC	National Pipe, Straight-coupling	sil.	silencer
kVA	kilovolt ampere	NPT	National Standard taper pipe thread per general use	SMTP	simple mail transfer protocol
kVAR	kilovolt ampere reactive	NPTF	National Pipe, Taper-Fine	SN	serial number
kW	kilowatt	NR	not required, normal relay	SNMP	simple network management protocol
kWh	kilowatt-hour	ns	nanosecond	SPDT	single-pole, double-throw
kWm	kilowatt mechanical	OC	overcrank	SPST	single-pole, single-throw
kWth	kilowatt-thermal	OD	outside diameter	spec	specification
L	liter	OEM	original equipment manufacturer	specs	specification(s)
LAN	local area network	OF	overfrequency	sq.	square
L x W x H	length by width by height	opt.	option, optional	sq. cm	square centimeter
lb.	pound, pounds	OS	oversize, overspeed	sq. in.	square inch
lbm/ft ³	pounds mass per cubic feet	OSHA	Occupational Safety and Health Administration	SMS	short message service
LCB	line circuit breaker	OV	overvoltage	SS	stainless steel
LCD	liquid crystal display	oz.	ounce	std.	standard
LED	light emitting diode	p., pp.	page, pages	stl.	steel
Lph	liters per hour	PC	personal computer	tach.	tachometer
Lpm	liters per minute	PCB	printed circuit board	TB	terminal block
LOP	low oil pressure	pF	picofarad	TCP	transmission control protocol
LP	liquefied petroleum	PF	power factor	TD	time delay
LPG	liquefied petroleum gas	ph., ∅	phase	TDC	top dead center
LS	left side	PHC	Phillips® head Crimptite® (screw)	TDEC	time delay engine cooldown
L _{wa}	sound power level, A weighted	PHH	Phillips® hex head (screw)	TDEN	time delay emergency to normal
LWL	low water level	PHM	pan head machine (screw)	TDES	time delay engine start
LWT	low water temperature	PLC	programmable logic control	TDNE	time delay normal to emergency
m	meter, milli (1/1000)	PLC	programmable logic control	TDOE	time delay off to emergency
M	mega (10 ⁶ when used with SI units), male	PMG	permanent magnet generator	TDON	time delay off to normal
m ³	cubic meter	pot	potentiometer, potential	temp.	temperature
m ³ /hr.	cubic meters per hour	ppm	parts per million	term.	terminal
m ³ /min.	cubic meters per minute	PROM	programmable read-only memory	THD	total harmonic distortion
mA	milliampere	psi	pounds per square inch	TIF	telephone influence factor
man.	manual	psig	pounds per square inch gauge	tol.	tolerance
max.	maximum	pt.	pint	turbo.	turbocharger
MB	megabyte (2 ²⁰ bytes)	PTC	positive temperature coefficient	typ.	typical (same in multiple locations)
MCCB	molded-case circuit breaker	PTO	power takeoff	UF	underfrequency
MCM	one thousand circular mils	PVC	polyvinyl chloride	UHF	ultrahigh frequency
megggar	megohmmeter	qt.	quart, quarts	UIF	user interface
MHz	megahertz	qty.	quantity	UL	Underwriter's Laboratories, Inc.
mi.	mile	R	replacement (emergency)	UNC	unified coarse thread (was NC)
mil	one one-thousandth of an inch	rad.	power source	UNF	unified fine thread (was NF)
min.	minimum, minute	RAM	radiator, radius	univ.	universal
misc.	miscellaneous	RAM	random access memory	URL	uniform resource locator (web address)
MJ	megajoule	RDO	relay driver output	US	undersize, underspeed
mJ	millijoule	ref.	reference	UV	ultraviolet, undervoltage
mm	millimeter	rem.	remote	V	volt
mOhm, mΩ	milliohm	Res/Coml	Residential/Commercial	VAC	volts alternating current
MOhm, MΩ	megohm	RFI	radio frequency interference	VAR	voltampere reactive
MOV	metal oxide varistor	RH	round head	VDC	volts direct current
MPa	megapascal	RHM	round head machine (screw)	VFD	vacuum fluorescent display
mpg	miles per gallon	rly.	relay	VGA	video graphics adapter
mph	miles per hour	rms	root mean square	VHF	very high frequency
MS	military standard	rnd.	round	W	watt
ms	millisecond	RO	read only	WCR	withstand and closing rating
m/sec.	meters per second	ROM	read only memory	w/	with
mtg.	mounting	rot.	rotate, rotating	WO	write only
MTU	Motoren-und Turbinen-Union	rpm	revolutions per minute	w/o	without
MW	megawatt	RS	right side	wt.	weight
mW	milliwatt	RTDs	Resistance Temperature Detectors	xfrm	transformer
μF	microfarad				
N, norm.	normal (power source)				
NA	not available, not applicable				
nat. gas	natural gas				

Appendix B Screen Summaries

For reference, this section lists the items displayed during normal operation, and the information and settings shown in the View screens and Setup menus.

Operation Screens

Main Screen

- System Status
- Next Exercise Time and Date
- Normal and Emergency Voltage
- Frequency
- Lamp Test
- Current, Amps
- Time/Date
- Daylight Saving Time Info
- Preferred Source
- Source-Source Type (Util-Gen)
- Commit/No Commit to Transfer
- Standard/Programmed/Closed Transition
- Phase Rotation (3-phase only)
- In-Phase Monitoring Enabled/Disabled

Test Sequence Screens

- Enter Password
- Type of Test
 - Loaded/Unloaded/Auto Load/Sync Check
 - Auto Load Test Run Time
- Test Sequence Status Screens
 - Active Time Delay with Time Remaining
 - Source Voltages
 - End Delay Button
 - End Test Button
 - Phase Angle (sync check only)

Exerciser Sequence (during exercise run)

- Exerciser Active
- Source Voltages
- Time Remaining (in exercise run)
- End Exercise Button

View Screens

Main Screen

- System Status
- Next Exercise Time and Date
- Normal and Emergency Voltage

View Event History

- Event Description
- Date and Time of event

View Maintenance Records

- Total Min Not Preferred
- Reset Min Not Preferred
- Total Min in Standby
- Reset Min in Standby
- Total Min Operation
- Reset Min Operation
- Total Transfers
- Reset Transfers
- Total Fail Transfer
- Reset Fail Transfer
- Total Loss Pref Tran
- Reset Lodd Pref Tran
- Transfer Time N>E
- Transfer Time E>N
- System Start Date
- Last Maint Date
- Last Loss Duration
- Last Loss Date/Time

View Exerciser Setup

- Exercise Event Number
- Enabled/Disabled
- Exercise Run Time
- Start Date
- Start Time
- Weekly/Biweekly
- Loaded/Unloaded

View System Setup

- Standard/Programmed/Closed Transition
- Source Type: Util/Gen
- In-Phase Monitor Enabled/Disabled
- Commit/No Commit to Transfer
- # I/O Modules Installed
- Rated Current
- Remote Test Loading Loaded/Unloaded
- Peak Shave Delay Enabled/Disabled

View Source Setup

- ABC/BAC Rotation (3-phase only)
- System Voltage, Normal/Emergency
- Frequency (Hz), Source N and E
- Normal Under Voltage PU% and DO%
 - Normal Over Voltage PU% and DO%
 - Debounce Time, Seconds
- Normal Under Frequency PU% and DO%
 - Debounce Time
- Normal Voltage Unbalance Enable/Disable
 - Normal Voltage Unbalance PU% and DO%
- Emergency Under Voltage PU% and DO%
 - Emergency Over Voltage PU% and DO%
 - Debounce Time
- Emergency Under Frequency PU% and DO%
 - Emergency Over Frequency PU% and DO%
 - Debounce Time
- Emergency Voltage Unbalance Enable/Disable
 - Emergency Voltage Unbalance PU% and DO%
- In-Phase Monitor
 - Enabled/Disabled
 - Angle, degrees
- In-Phase Transfer Fail
 - Enabled/Disabled
 - Time Delay min:sec
- Synchronization (for closed-transition)
 - Voltage Differential
 - Frequency Differential
 - Angle differential
- Fail to Sync

-
- Enabled/Disabled
 - Time Delay min:sec
-

View Time Delays, Source S1 and Source S2

- Engine Start (Source S2 only)
- Engine Cooldown (Source S2 only)
- Xfr Preferred>Standby (Standby>Preferred)
- Xfr Off > Standby (Off >Preferred) (programmed-transition only)
- Fail to Acquire Standby
- Load Control
 - Mode: None/Time
 - Loads to Control (1-9)
- Time-Based Control
 - Load Disconnect N>E (E>N) Time Delay min:sec
 - Load Reconnect E>N (N>E) Time Delay min:sec

View Inputs/Outputs

- Main Board I/O
 - Input Function Descriptions (2)
 - Output Function Descriptions (2)
- Auxiliary Inputs/ Outputs (optional modules)
 - Module Type and Address
 - Module Status
 - Input Function Descriptions
 - Output Function Descriptions

View Common Alarms

- Alarm Group (1 and 2)
- Alarm Description
- Audible (Yes or No)
- Common (Yes or No)

View Communications Setup

- Modbus Server TCP Enabled/Disabled
- Modbus Server Port 0, Enable/Disabled
- Modbus Address Port 0
- Baud Rate Port 0, 9600/19200/57600
- Modbus TCP Unit ID
- IP Address
- Subnet Mask
- MAC Address

View Control Parameters

- Application Version (factory-set)
- ATS Serial Number (factory-set)
- Controller Serial Number (factory-set)
- Contactor Serial Number (factory-set)
- Site Designation (optional; use SiteTech to set)
- Load Description (optional; use SiteTech to set)
- Branch Description (optional; use SiteTech to set)
- Location (optional; use SiteTech to set)

Setup Menus

Set Time/Date

- Set Time
- Set Date
- Set Automatic Daylight Saving Time

Set Exerciser

For each exerciser event:

- Enable/Disable
- Loaded/Unloaded
- Interval
- Repeat Rate
- Duration
- Start Date
- Start time

Set S1/S2 Time Delays

- Engine Start (Source S2 only)
 - External Battery? Y or N
 - Time Delay min:sec
- Engine Cooldown Time Delay min:sec (Source S2 only)
- Xfr Preferred>Standby (Standby>Preferred)
- Xfr Off > Standby (Off >Preferred)
(programmed- transition only)
- Fail to Acquire Standby
 - Enable/Disable
 - Time Delay min:sec
- Load Control
 - Mode: None/Time
 - Loads to Control (1-9)
- Time-Based Control (for each connected load)
 - Load Disconnect N>E (E>N) Time Delay min:sec
 - Load Reconnect E>N (N>E) Time Delay min:sec

Set Source

- Phase Rotation ABC/BAC/Disabled
- Set In-Phase Monitor
 - Enable/Disable
 - Angle
 - In-Phase Transfer Fail Time Delay
 - Enable/Disable
 - Time Delay min:sec
- Set Synchronization (closed-transition models only)
 - Voltage Differential
 - Frequency Differential
 - Angle Differential
 - Fail to Sync
 - Enable/Disable
 - Time Delay min:sec
- Set Preferred Source Normal/Emergency (alarm module required)
- Set Normal (Emergency) Source:
 - Number of Phases
 - Voltage
 - Frequency
 - Under Voltage Pickup
 - Under Voltage Dropout
 - Over Voltage Pickup
 - Over Voltage dropout
 - Voltage Debounce Time
 - Voltage Unbalance Enable/Disable (3 phase only)
 - Voltage Unbalance Pickup (3 phase only)
 - Voltage Unbalance Dropout (3 phase only)
 - Under Frequency Pickup (Emergency source only)
 - Under Frequency Dropout (Emergency source only)
 - Over Frequency Pickup (Emergency source only)
 - Over Frequency Dropout (Emergency source only)
 - Frequency Debounce time (Emergency source only)

Set Input/Output

- Set Main Board I/O
 - Set Input Functions *
 - Set Output Functions †
- Set Auxiliary I/O (Modules)
 - Set Input Functions *
 - Set Output Functions †

* See Section 4.7.3, Input Functions

† See Section 4.7.4, Output Functions.

Set Common Alarms

- Alarm Group 1 or 2
- Modify Alarm
 - Audible (Yes/No)
 - Common (Yes/No)
- Remove All Alarms Yes/No

Set System

- Source Type: Util-Gen
- Transition Type: Standard/Programmed/Closed
 - Prog Transition Override Automatic/Manual (closed-transition only)
- Rated Current, Amps
- Transfer Commit Commit/No Commit
- Remote Test Loading Loaded/Unloaded
- Peak Shave TD Bypass Enable/Disable

Set Communications

- Modbus Server TCP Enable/Disable
- Modbus Server Port 0, Enable/Disable
- Modbus Address Port 0
- Baud Rate Port 0, 9600/19200/57600
- Modbus TCP Unit ID
- IP Address
- Subnet Mask
- Default Gateway
- DHCP Status

Set Passwords

- Setup Password
- Test Password

Calibration

- Line-Neutral Voltages, Source N and E, all phases
- Line-Line Voltages, Source N and E, all phases
- Load Current, LA, LB, and LC

Reset Data

- Reset Maintenance Records, Yes or No
- Reset Event History, Yes or No
- Reset Default Parameters, Yes or No
- Reset Exercise Setup, Yes or No
- Reset Test Password, Yes or No
- Disable Test Password, Yes or No
- File Maintenance
 - Delete Files
 - Force History Save

TP-6866 6/21e

© 2014 Kohler Co. All rights reserved.

KOHLER®

KOHLER CO., Kohler, Wisconsin 53044
Phone 920-457-4441, Fax 920-459-1646
For the nearest sales/service outlet in the
US and Canada, phone 1-800-544-2444
KOHLERPower.com