

KD83V16

KOHLER® KD SERIES™ ENGINE

KOHLER G-Drive diesel engines produce industry-leading kW displacement in a package that enables a smaller generator set footprint while delivering best fuel consumption at more nodes than any competitor between 800 and 3250 kW. That means higher performance at reduced operating cost. The engine architecture, injection system and engine management of G-Drive engines have been designed to achieve optimal generator set performance while meeting all worldwide emission requirements.

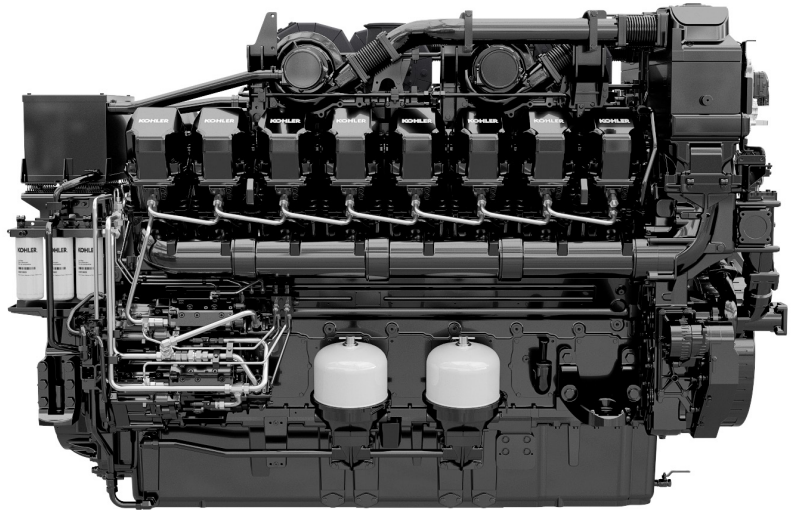

FEATURES

MATCHED TURBOCHARGERS

Turbochargers have been designed for maximum power and optimal combustion. They are specifically matched to each engine and engineered to provide the required amount of air at all times, which reduces fuel consumption and enables operation at high altitudes.

FUEL SYSTEM

The common rail fuel system generates up to 2200-bar injection pressures for maximum efficiency, optimizing the combustion pressure curve through multiple injections. An ideal injection point and extremely uniform injection quantity create exceptionally low noise and deliver very stable power. Engineers specifically designed the remarkable fuel system to work optimally for KOHLER G-Drive engines.

INTUITIVE ENGINE CONTROL UNIT (ECU)

The ECU includes a number of physical parameters for optimal control of the injection system and long-life service. It is designed to work seamlessly within the generator set and to communicate with KODIA, our intuitive diagnostic software, to allow monitoring of the engine performance.

Designed and developed specifically for this engine series, each ECU works with the generator set controller—receiving important engine operating data and allowing the generator set controller to manage the entire system.

INNOVATIVE CYLINDER HEAD DESIGN

Featuring a “crossflow” design and new valve orientation, our innovative cylinder head design includes more efficient fuel delivery, combustion and exhaust gas flow. High-quality materials were chosen for better performance and a strengthened structure.

CRANKCASE VENTILATION

Enhanced crankcase ventilation enables our engines to operate under the highest temperature fluctuations and prevents heat from affecting power output. This closed-loop regeneration system increases filtration efficiency and results in a more environmentally friendly engine.

KOHLER
IN POWER. SINCE 1920.

KD83V16

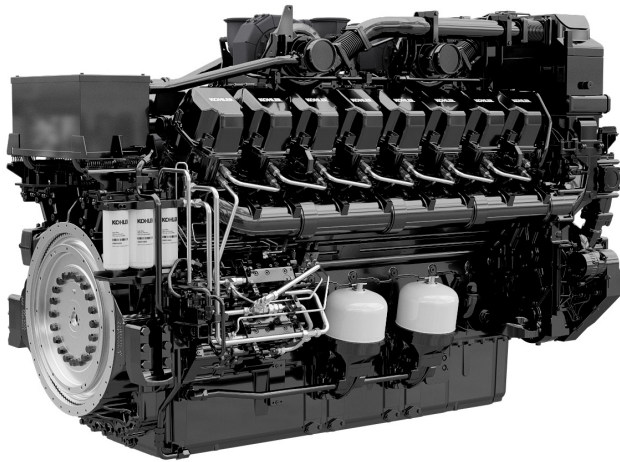

STANDARD EQUIPMENT

Induction System

Turbocharged after-cooled; new modular turbocharged system delivers the optimal quantity of air to reach maximum power and reduce fuel consumption during operation.

Fuel System

The common rail fuel system generates up to 2200-bar injection pressures for maximum efficiency. An ideal injection point and extremely uniform injection quantity create exceptionally low noise and deliver very stable power.

Cooling System

Water-cooled; thermostat for jacket water-cooling system; water pump; thermostat for water-charge air cooling system; radiator-supplied loose incorporating air-to-water charge cooler.

Lubrication System

Full-pressure water-cooled lubrication system; spin-on lubrication oil filters; oil temperature sensor.
Optional: Oil centrifugal filter.

Starting System

24-volt starting voltage; 140-amp battery charging alternator.

Engine Management

The engine control unit (ECU) provides optimal control of the injection system and communicates with KODIA, our intuitive diagnostic software, to allow monitoring of engine performance. The ECU also interoperates with the generator set controller for complete control of the entire system.

GENERAL DATA

Number of cylinders		16
Cylinder arrangement		60° V
Cycle		4-cycle
Bore	mm (in)	175 (6.9)
Stroke	mm (in)	215 (8.5)
Displacement	total L (cu in)	82.72 (5047.9)
Displacement, cylinder	total L (cu in)	5.17 (315.5)
Lube oil capacity	L	390
Coolant capacity	L	375
Flywheel dimensions		SAE 00

DIMENSIONS AND WEIGHT

Length	mm (in)	3240 (127.6)
Width	mm (in)	1777 (69.9)
Height	mm (in)	2125 (83.7)
Weight, dry	kg (lb)	11,300 (24,913)

GROSS POWER

1500 RPM (50 Hz)

Standby power	kWm/BHP	3007/4032
Prime power	kWm/BHP	2734/3666
Continuous power	kWm/BHP	2278/3055

1800 RPM (60 Hz)

Standby power	kWm/BHP	3490/4680
Prime power	kWm/BHP	3173/4255
Continuous power	kWm/BHP	2644/3544

EMISSION CERTIFICATION

1500 RPM (50 Hz)

Standby power	Exhaust emission EPA Tier 2 (not certified)
Prime power	Exhaust emission EPA Tier 2 (not certified)
Continuous power	Fuel-optimized

1800 RPM (60 Hz)

Standby power	U.S. EPA Nonroad Tier 2 stationary (40 CFR 60)
Prime power	U.S. EPA Nonroad Tier 2 stationary (40 CFR 60)
Continuous power	Fuel-optimized

RATINGS/POWER DEFINITIONS

STANDBY POWER

Applicable for supplying power to varying electrical loads for the duration of power interruption of a reliable utility source. Standby Power is in accordance with ISO 8528. Fuel stop power in accordance with ISO 3046, AS 2789, DIN 6271 and BS 5514.

PRIME POWER

Applicable for supplying power to varying electrical loads for unlimited hours. Prime Power is in accordance with ISO 8528. Ten percent overload capability is available in accordance with ISO 3046, AS 2789, DIN 6271 and BS 5514.

CONTINUOUS POWER

Applicable for supplying power continuously to a constant electrical load for unlimited hours. Continuous Power in accordance with ISO 8528, ISO 3046, AS 2789, DIN6271 and BS 5514.