

CENTER OF GRAVITY DIMENSIONS			WEIGHT DRY KG [LBS]	WEIGHT WET KG [LBS]
MODEL	CG X	CG Y		
145 REOZT4	1842 [72.5]	1341 [52.8]	4048 [8924]	4116 [9074]
175 REOZT4	1847 [72.7]	1341 [52.8]	4086 [9009]	4154 [9159]

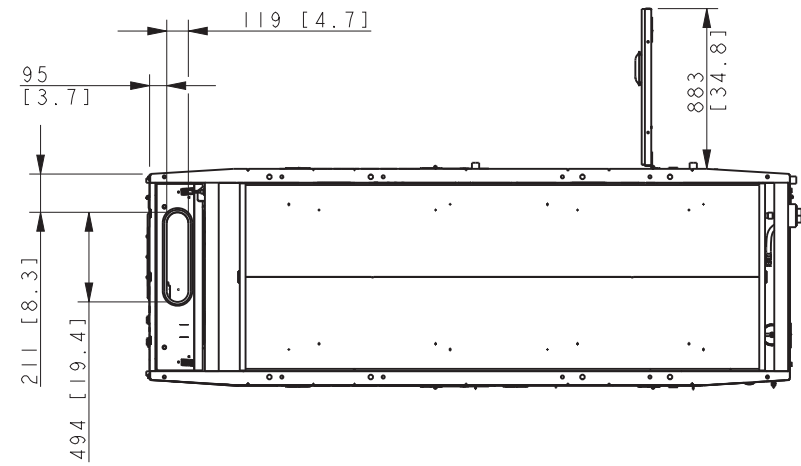
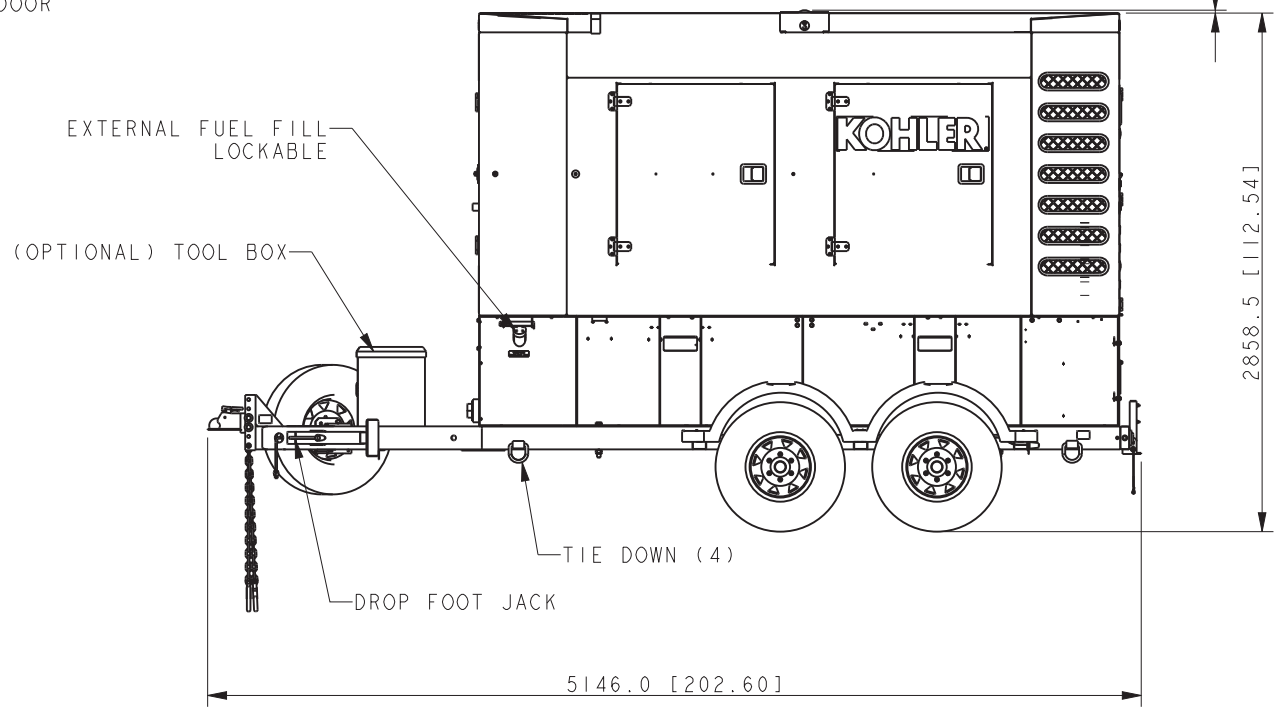
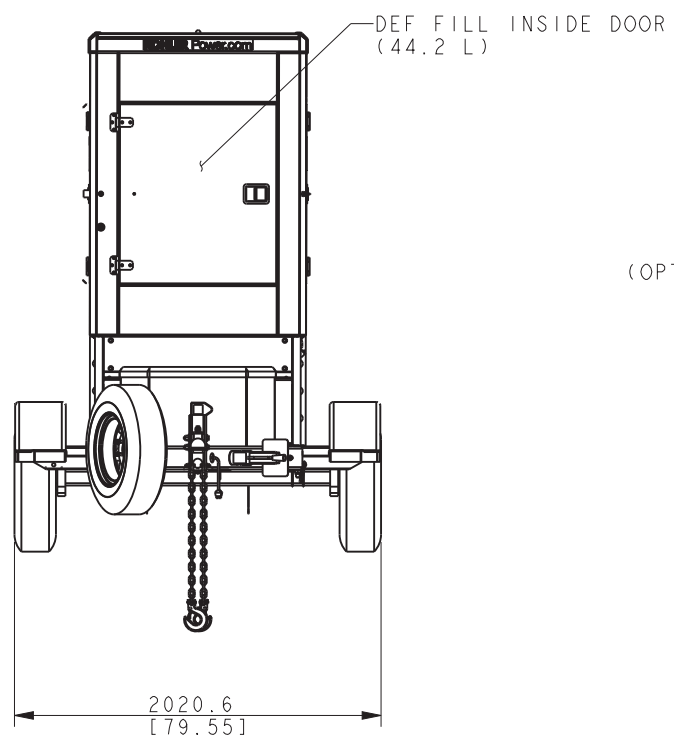
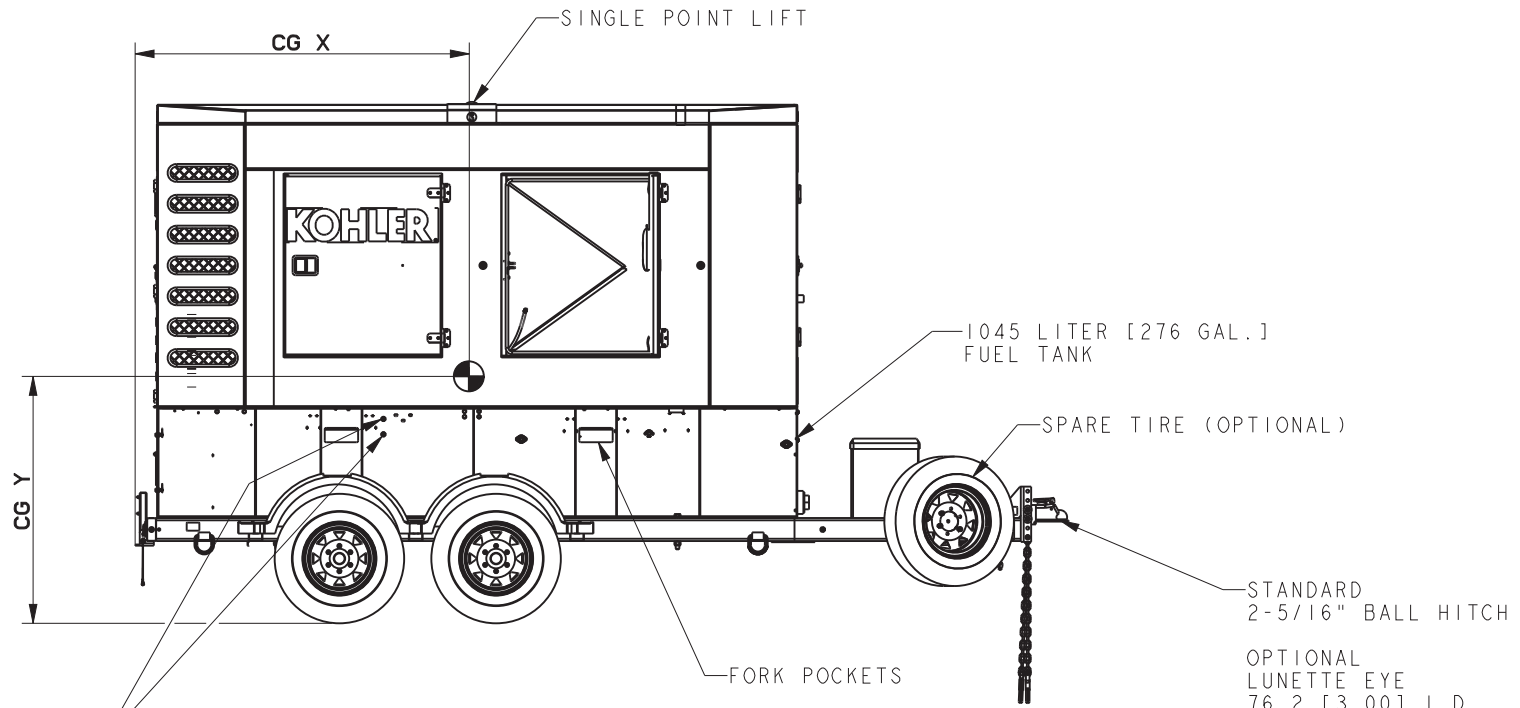
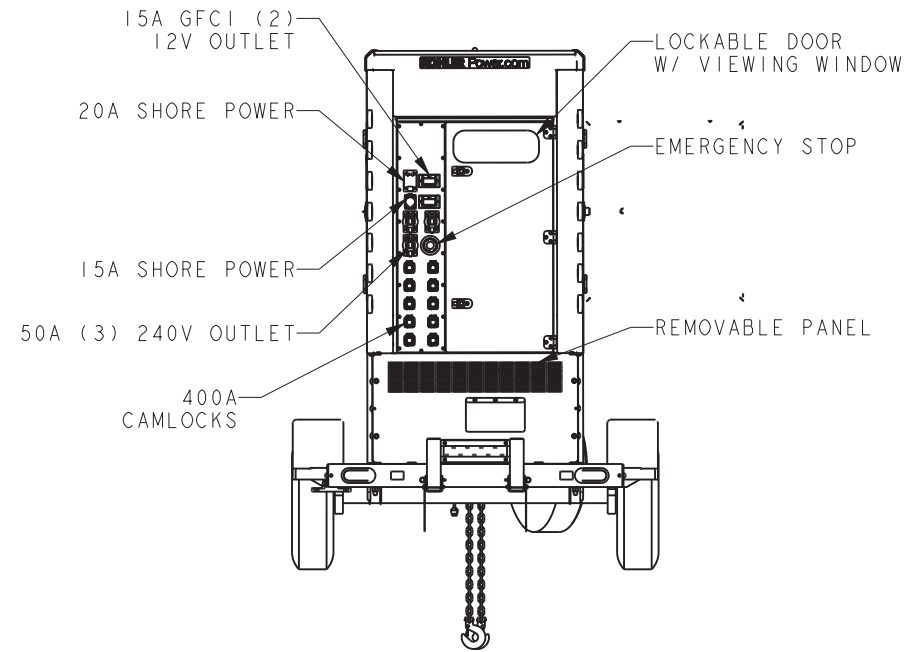

ENCLOSURE BOTTOM VIEW
TANK VIEW REMOVED FOR CLARITY

WEIGHTS LISTED DO NOT INCLUDE OPTIONAL TOOL BOX AND SPARE TIRE KITS.
WET WEIGHT INCLUDES ENGINE FLUIDS, EXCLUDING FUEL & DEF FLUID WEIGHT.
DIMENSIONS IN [] ARE IMPERIAL EQUIVALENTS

MOBILE
145-175 REOZT4

REV	DATE	ON COMPOSITE DWGS, SEE PART NO. FOR REVISION LEVEL	BY	DO NOT SCALE. REFERENCE THE MODEL FOR ALL UNSPECIFIED DIMENSIONS
-	24SEP2019	NEW DRAWING [CT198480]	TKK	UNLESS OTHERWISE SPECIFIED: ALL DIMENSIONS IN MILLIMETERS GENERAL TOLERANCES: N/A
A	14OCT2020	(A-5) 5146.0 [202.60] WAS 5115.9 [201.41]; (B-3) 2858.5 [112.54] WAS 2856.2 [112.45]; (A-8) 2020.6 [79.55] WAS 2004.1 [78.90]; (C-2) LUNETTE EYE 76.2 [3.00] WAS PINTLE HITCH 82.6 [3.25] I.D [CT207348]	PAR	
				THIRD ANGLE PROJECTION
APPROVALS		DATE		KOHLER KOHLER, WISCONSIN 53044 THIS DRAWING IN DESIGN AND DETAIL IS KOHLER CO. PROPERTY AND MUST NOT BE USED EXCEPT IN CONNECTION WITH KOHLER CO. WORK. ALL RIGHTS OF DESIGN OR INVENTION ARE RESERVED. TITLE DIMENSION PRINT, 145/175 REOZT4 SCALE 0.05 CAD NO. SHEET 1 of 3 DWG NO. ADV-9176
DRAWN		TKK 24SEP2019		
CHECKED		GFR 24SEP2019		
APPROVED		AJW 24SEP2019		

CENTER OF GRAVITY DIMENSIONS			WEIGHT DRY KG [LBS]	WEIGHT WET KG [LBS]
MODEL	CG X	CG Y		
145 REOZT4	1787 [70.3]	894 [35.2]	3500 [7715]	3568 [7865]
175 REOZT4	1789 [70.4]	894 [35.2]	3538 [7800]	3606 [7950]

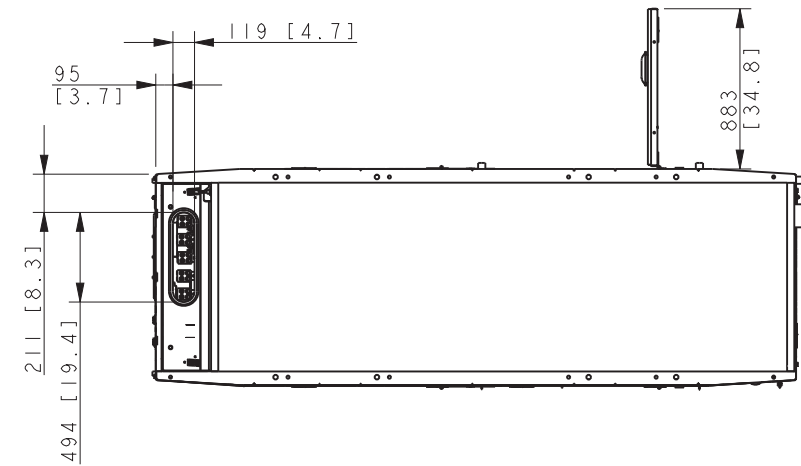
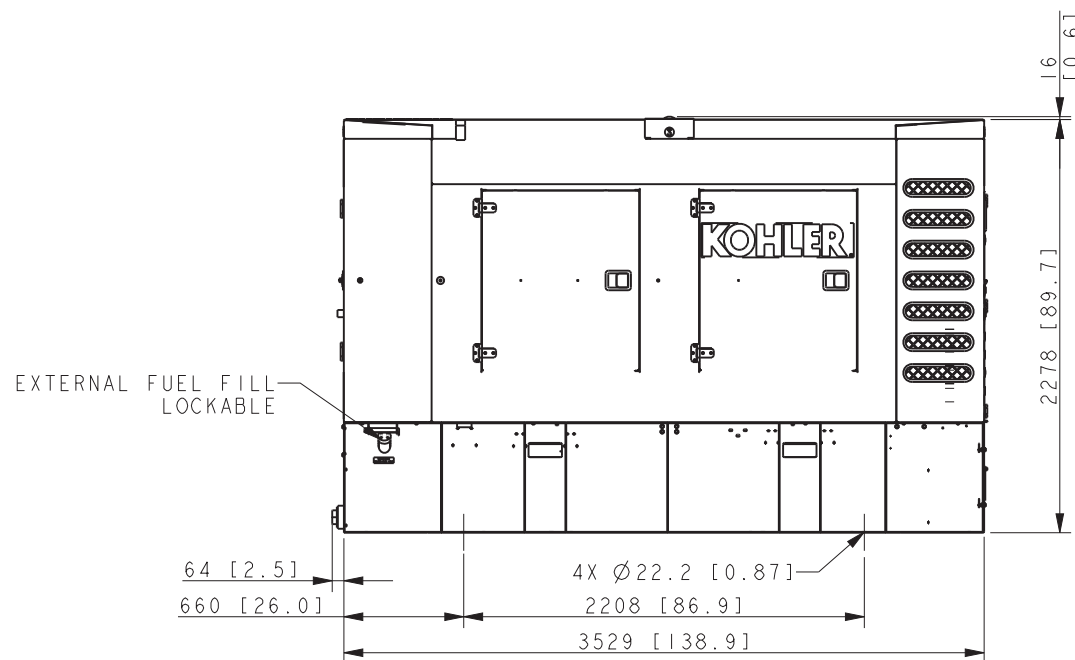
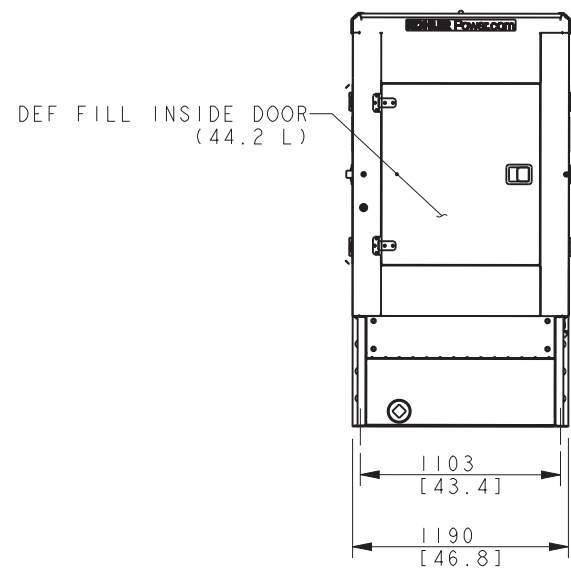
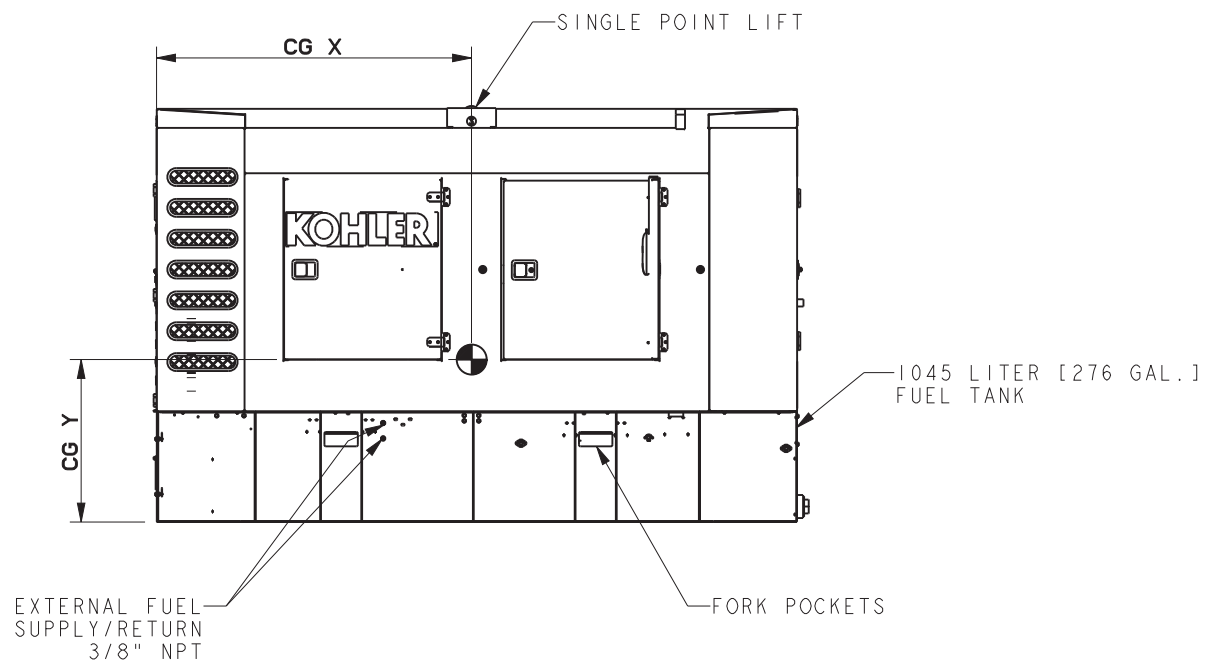
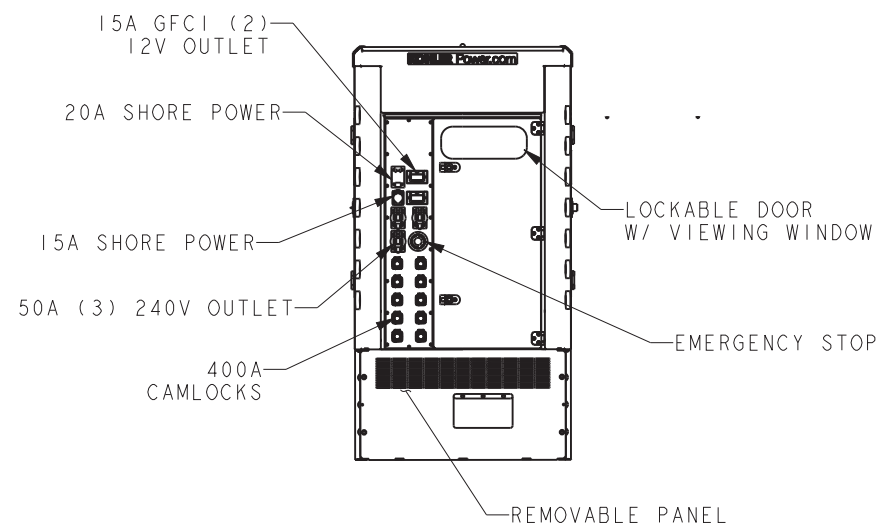

ENCLOSURE BOTTOM VIEW
TANK VIEW REMOVED FOR CLARITY

MOBILE
145-175 REOZT4

REV	DATE	ON COMPOSITE DWGS, SEE PART NO. FOR REVISION LEVEL	BY	DO NOT SCALE, REFERENCE THE MODEL FOR ALL UNSPECIFIED DIMENSIONS
-	24SEP2019	NEW DRAWING [CT198480]	TKK	UNLESS OTHERWISE SPECIFIED: ALL DIMENSIONS IN MILLIMETERS GENERAL TOLERANCES: N/A
A	14OCT2020	SEE SHEET 1 [CT207348]	PAR	
				KOHLER KOHLER, WISCONSIN 53044 THIS DRAWING IN DESIGN AND DETAIL IS KOHLER CO. PROPERTY AND MUST NOT BE USED EXCEPT IN CONNECTION WITH KOHLER CO. WORK. ALL RIGHTS OF DESIGN OR INVENTION ARE RESERVED.
				THIRD ANGLE PROJECTION
		APPROVALS	DATE	TITLE
		DRAWN	TKK 24SEP2019	DIMENSION PRINT, 145/175 REOZT4
		CHECKED	GFR 24SEP2019	SCALE 0.05 CAD NO. SHEET 2 of 3
		APPROVED	AJW 24SEP2019	DWG NO. ADV-9176 D

CENTER OF GRAVITY DIMENSIONS			WEIGHT DRY KG [LBS]	WEIGHT WET KG [LBS]
MODEL	CG X	CG Y		
145 REOZT4	1787 [70.3]	894 [35.2]	3515 [7749]	3583 [7899]
175 REOZT4	1789 [70.4]	894 [35.2]	3553 [7833]	3621 [7983]

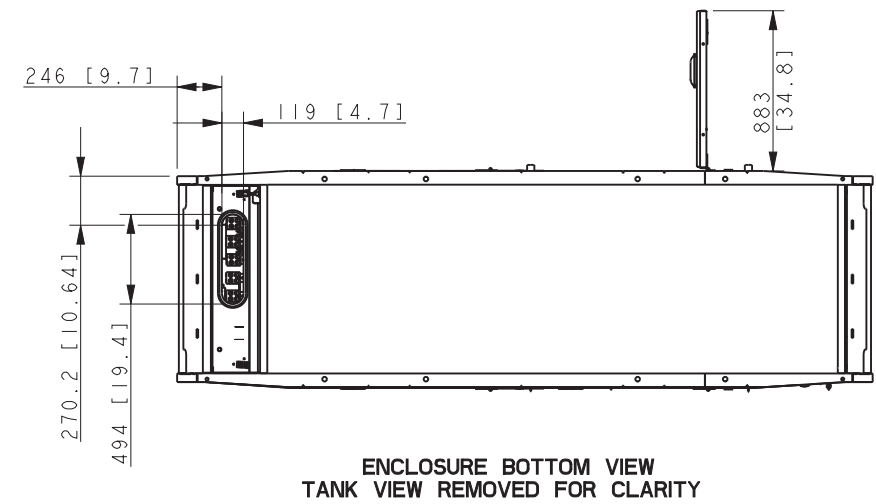
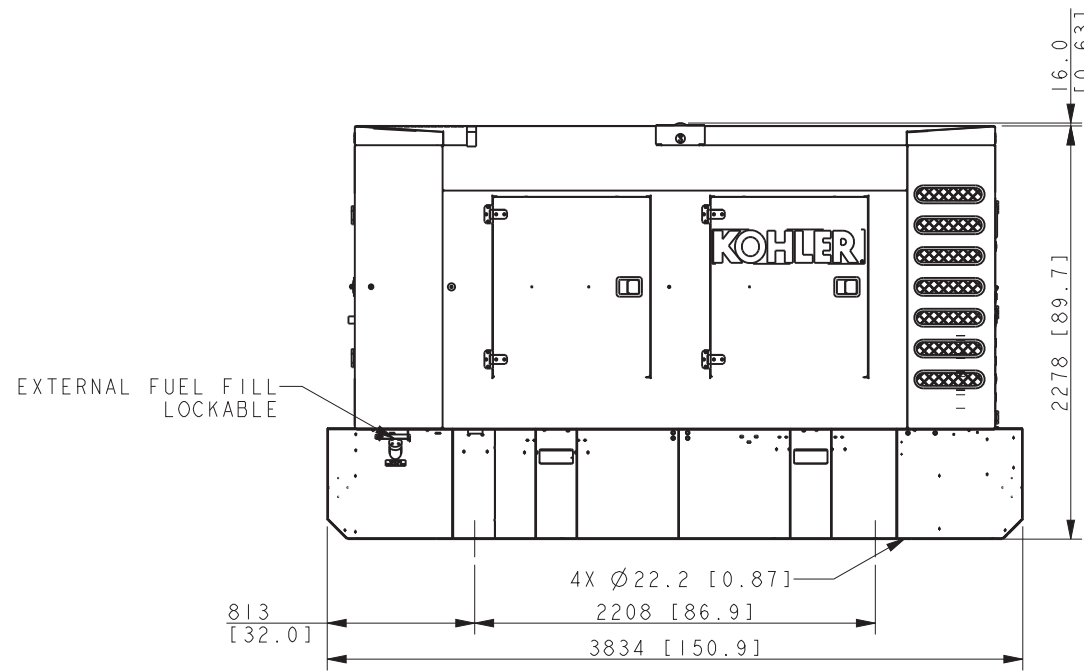
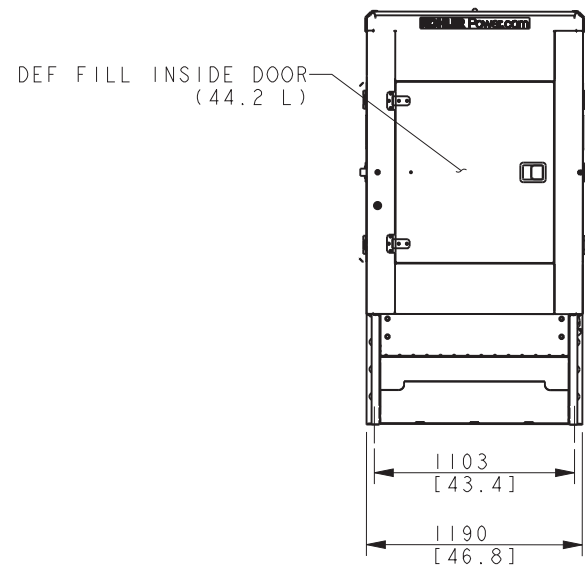
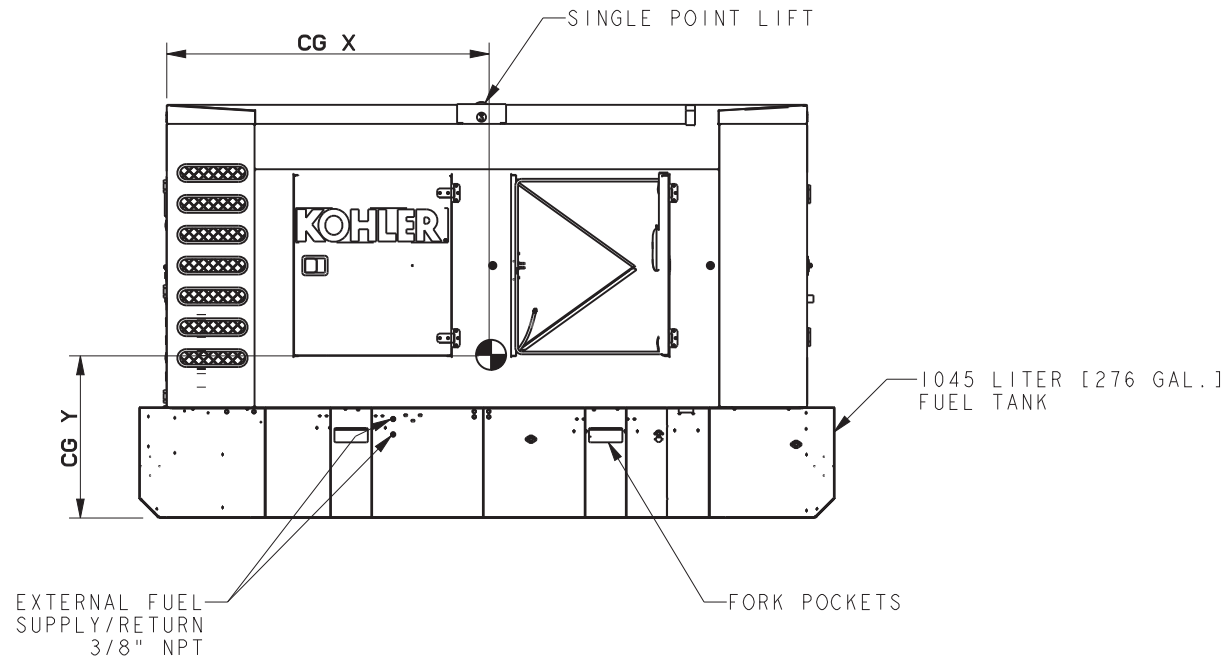
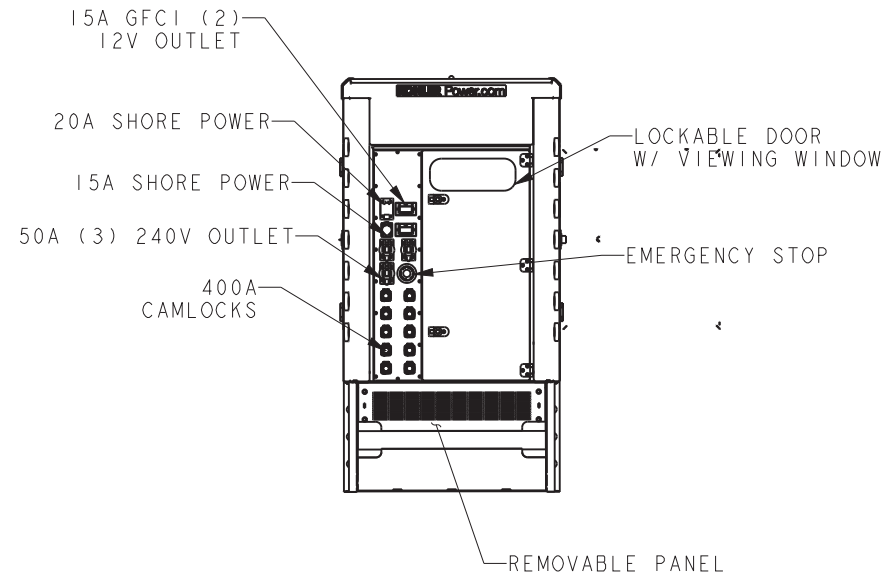

**FIELD DRAGGABLE
145-175 REOZT4**

REV	DATE	ON COMPOSITE DWGS, SEE PART NO. FOR REVISION LEVEL	BY	DO NOT SCALE, REFERENCE THE MODEL FOR ALL UNSPECIFIED DIMENSIONS
-	24SEP2019	NEW DRAWING [CT198480]	TKK	UNLESS OTHERWISE SPECIFIED: ALL DIMENSIONS IN MILLIMETERS GENERAL TOLERANCES: N/A
A	14OCT2020	SEE SHEET 1 [CT207348]	PAR	
				THIRD ANGLE PROJECTION
APPROVALS		DATE		
DRAWN		TKK 24SEP2019		
CHECKED		GFR 24SEP2019		
APPROVED		AJW 24SEP2019		TITLE DIMENSION PRINT, 145/175 REOZT4
				SCALE 0.05 CAD NO. SHEET 3 of 3 DWG NO. ADV-9176

KOHLER
 KOHLER, WISCONSIN 53044
 THIS DRAWING IN DESIGN AND DETAIL IS KOHLER CO. PROPERTY AND MUST NOT BE USED EXCEPT IN CONNECTION WITH KOHLER CO. WORK. ALL RIGHTS OF DESIGN OR INVENTION ARE RESERVED.