

CENTER OF GRAVITY DIMENSIONS			WEIGHT DRY KG [LBS]	WEIGHT WET KG [LBS]
MODEL	CG X	CG Y		
90REOZT4	1544 [60.8]	1066 [41.9]	3114 [6865]	3162 [6970]
120REOZT4	1556 [61.3]	1081 [42.5]	3223 [7105]	3270 [7210]

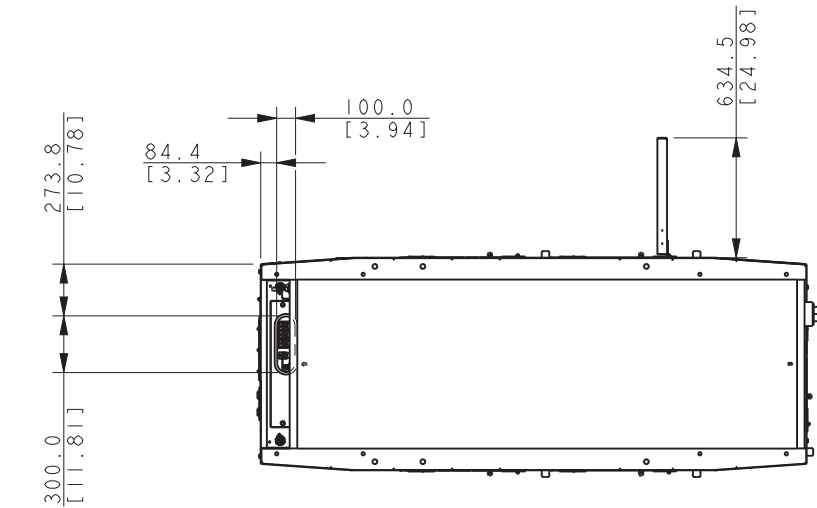
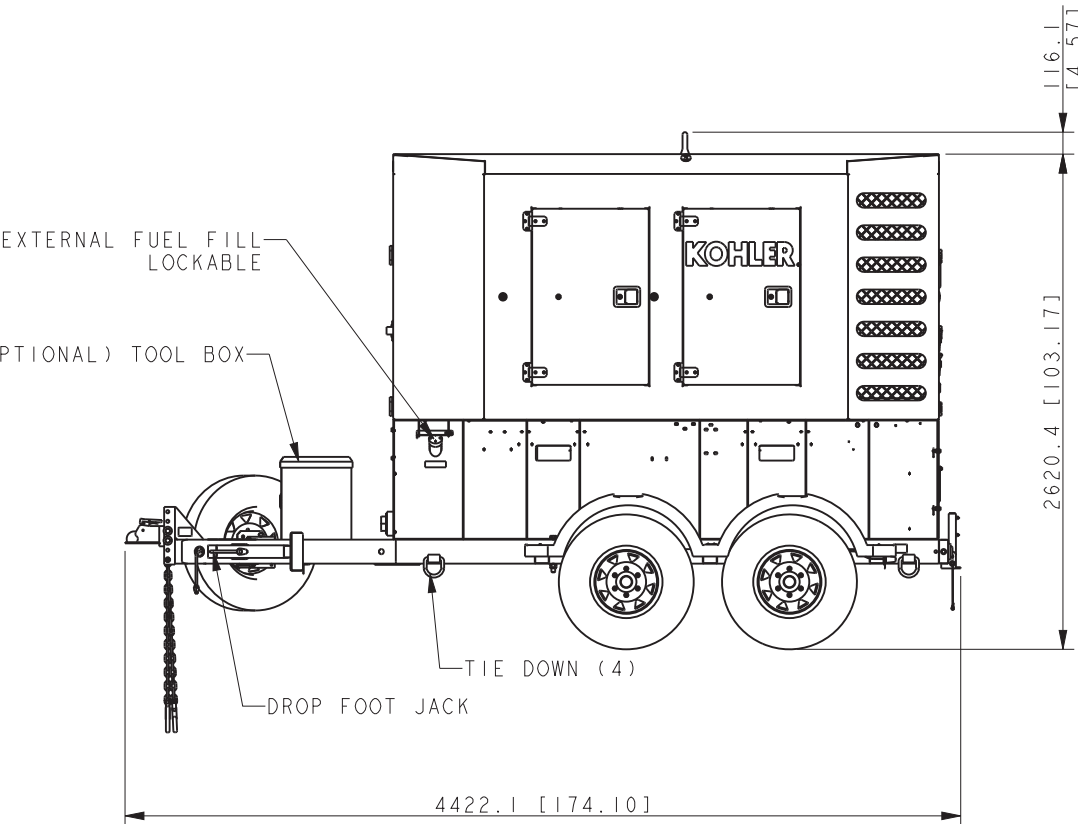
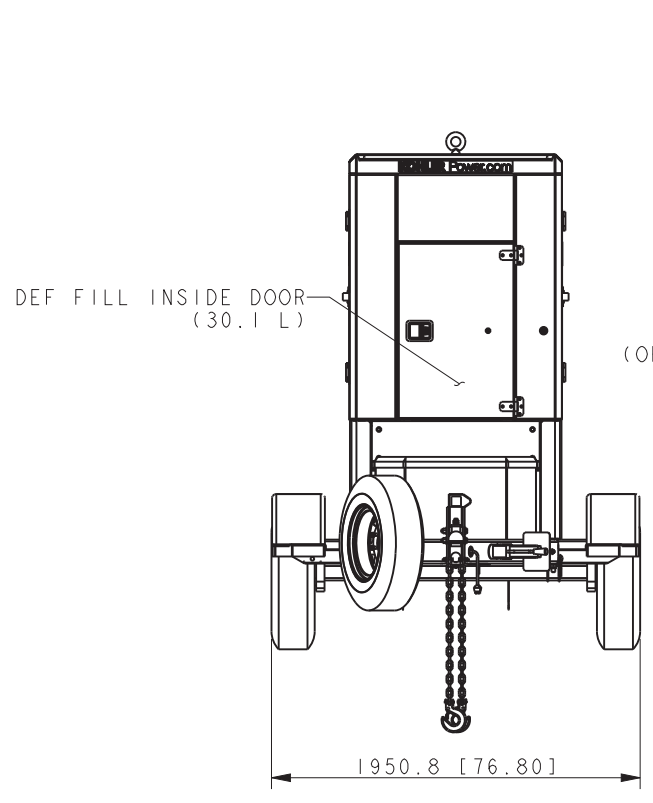
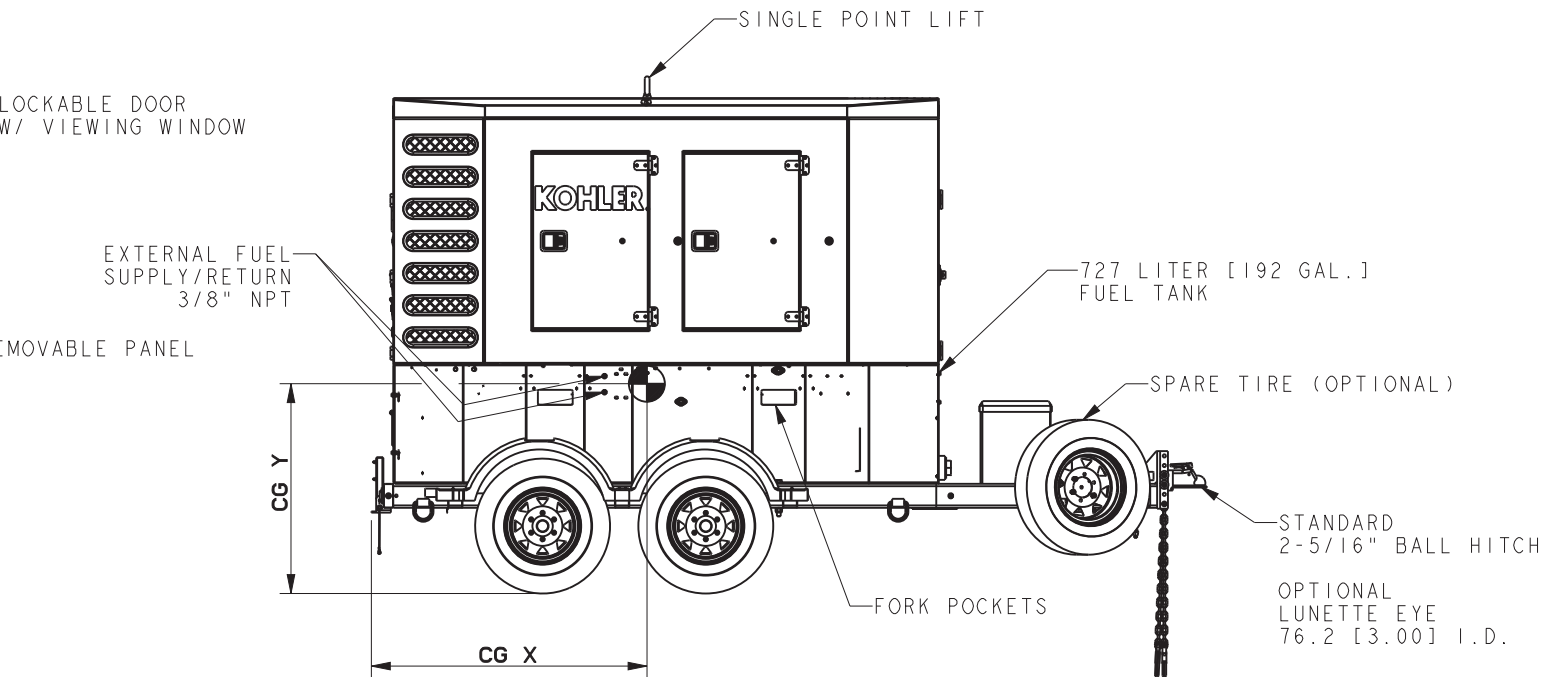
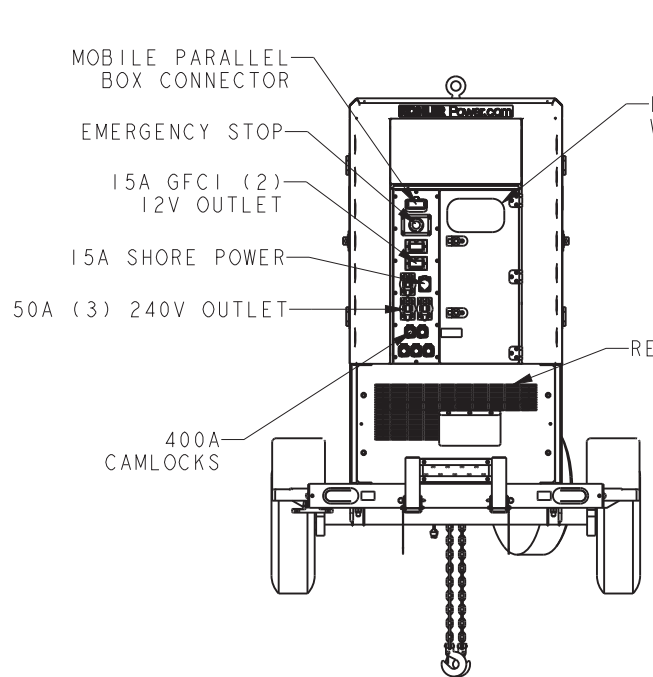

ENCLOSURE BOTTOM VIEW  
TANK VIEW REMOVED FOR CLARITY

DIMENSIONS IN [ ] ARE IMPERIAL EQUIVALENTS  
WET WEIGHT INCLUDES ENGINE FLUIDS, EXCLUDING FUEL & DEF FLUID WEIGHT.  
WEIGHTS LISTED DO NOT INCLUDE OPTIONAL TOOL BOX AND SPARE TIRE KITS.

REV	DATE	ON COMPOSITE DWGS, SEE PART NO. FOR REVISION LEVEL	BY	DO NOT SCALE, REFERENCE THE MODEL FOR ALL UNSPECIFIED DIMENSIONS												
-	23SEP2019	NEW DRAWING [CT198480]	TKK	UNLESS OTHERWISE SPECIFIED: ALL DIMENSIONS IN MILLIMETERS GENERAL TOLERANCES: X.XX ± 0.25 X.X ± 1.0 SURFACE FINISH X ± 1.5 ANGLES ± 0°30' MAX. THIRD ANGLE PROJECTION												
A	14OCT2020	VIEWS UPDATED; (A-5) 4422.1 [174.10] WAS 4394.1 [173.00]; (B-4) 2620.4 [103.17] WAS 2566.3 [101.04]; (A-7) 1950.8 [76.80] WAS 1981.9 [78.03]; (C-3) LUNETTE EYE 76.2 [3.00] WAS PINTLE HITCH 82.6 [3.25]; (D-6) WET & DRY WEIGHT VALUES UPDATED; (D-7) CG Y VALUES UPDATED [CT207348]	PAR													
				APPROVALS	DATE											
				DRAWN	TKK 23SEP2019											
				CHECKED	GFR 23SEP2019											
				APPROVED	AJW 23SEP2019											
<table border="0"> <tr> <td colspan="2">TITLE</td> <td colspan="2">SCALE 0.05</td> <td>CAD NO.</td> <td>SHEET 1 of 3</td> </tr> <tr> <td colspan="2">DIMENSION PRINT, 90/120 REOZT4</td> <td colspan="2">ADV-9175</td> <td></td> <td>D</td> </tr> </table>					TITLE		SCALE 0.05		CAD NO.	SHEET 1 of 3	DIMENSION PRINT, 90/120 REOZT4		ADV-9175			D
TITLE		SCALE 0.05		CAD NO.	SHEET 1 of 3											
DIMENSION PRINT, 90/120 REOZT4		ADV-9175			D											

MOBILE

CENTER OF GRAVITY DIMENSIONS			WEIGHT DRY KG [LBS]	WEIGHT WET KG [LBS]
MODEL	CG X	CG Y		
90REOZT4	1491 [58.7]	605 [23.8]	2495 [5500]	2542 [5605]
120REOZT4	1506 [59.3]	607 [24.0]	2612 [5760]	2660 [5865]

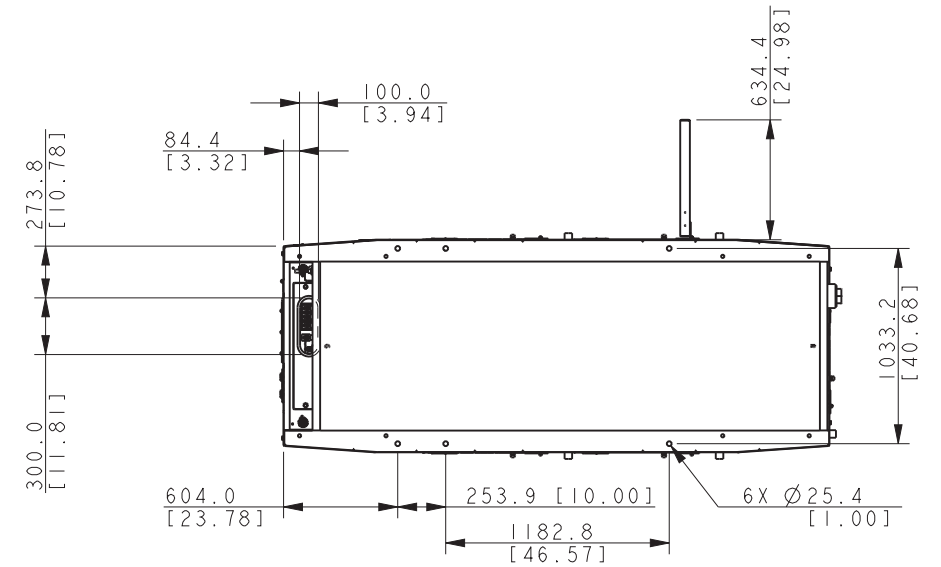
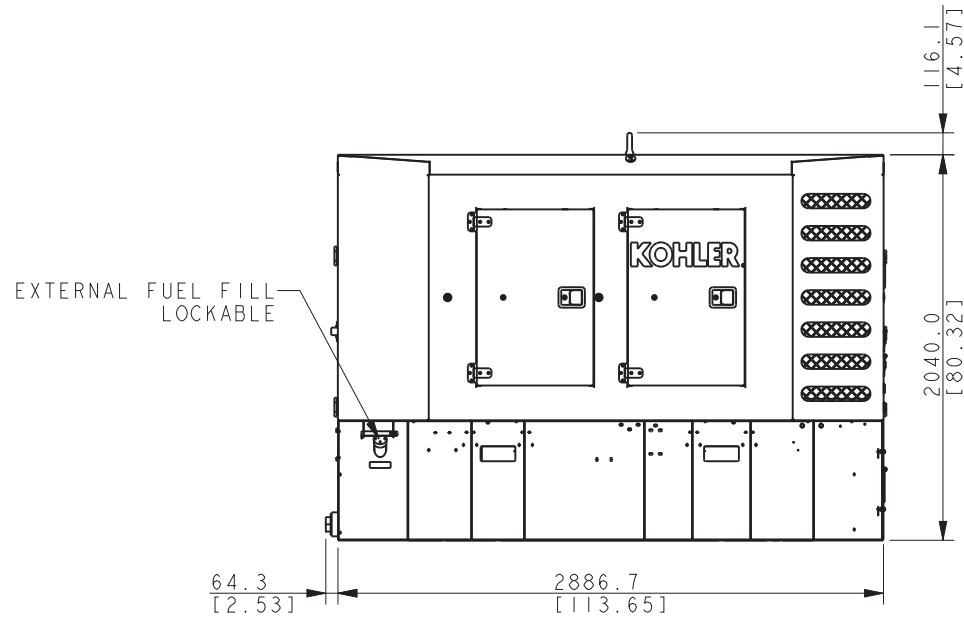
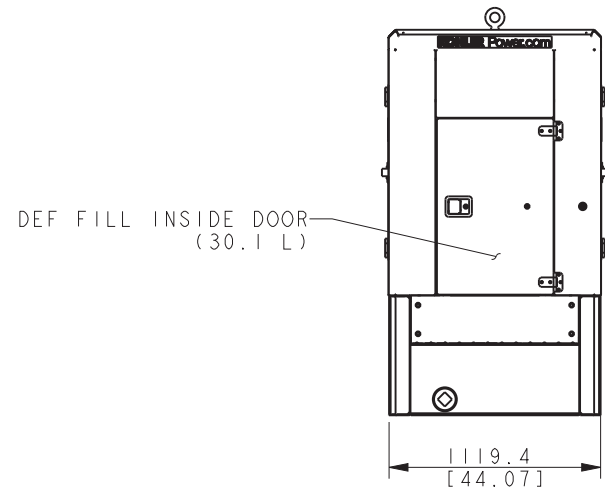
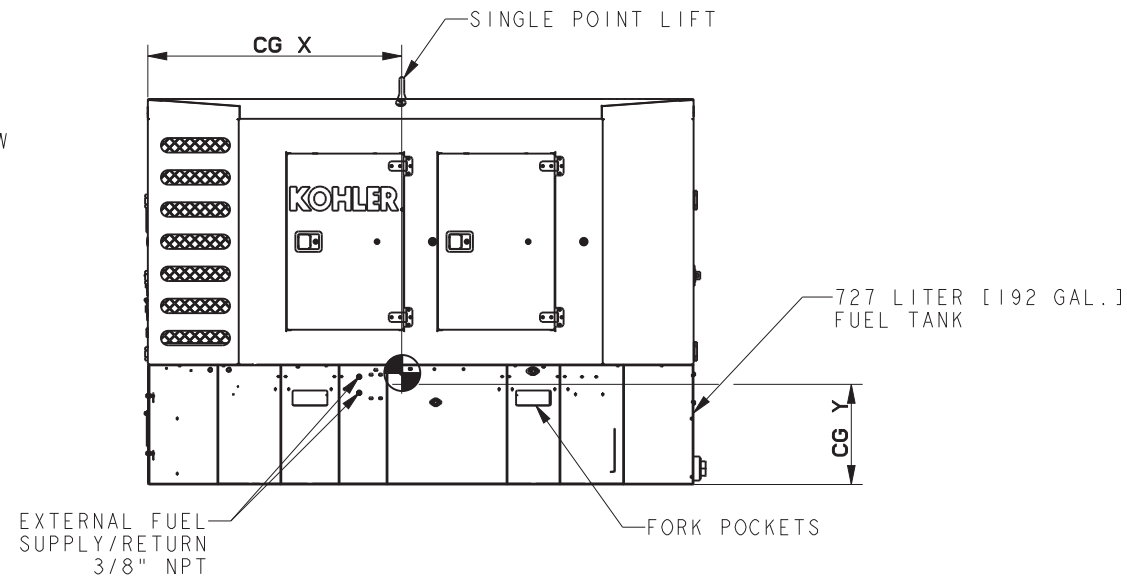
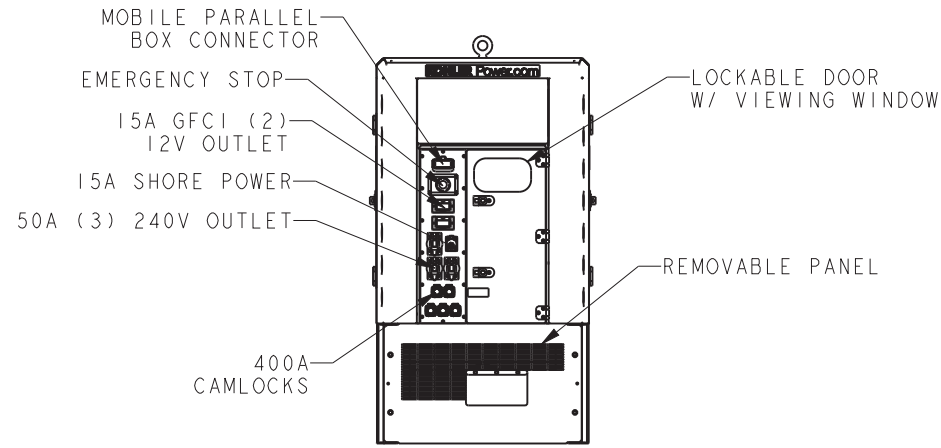

ENCLOSURE BOTTOM VIEW  
TANK VIEW REMOVED FOR CLARITY

MOBILE

REV	DATE	ON COMPOSITE DWGS, SEE PART NO. FOR REVISION LEVEL	BY	DO NOT SCALE. REFERENCE THE MODEL FOR ALL UNSPECIFIED DIMENSIONS
-	23SEP2019	NEW DRAWING [CT198480]	TKK	UNLESS OTHERWISE SPECIFIED: ALL DIMENSIONS IN MILLIMETERS GENERAL TOLERANCES: X.XX ± 0.25 X.X ± 1.0 SURFACE FINISH X ± 1.5 ANGLES ± 0°30' MAX. THIRD ANGLE PROJECTION
A	14OCT2020	SEE SHEET 1 [CT207348]	PAR	
				<b>KOHLER</b> KOHLER, WISCONSIN 53044 THIS DRAWING IN DESIGN AND DETAIL IS KOHLER CO. PROPERTY AND MUST NOT BE USED EXCEPT IN CONNECTION WITH KOHLER CO. WORK. ALL RIGHTS OF DESIGN OR INVENTION ARE RESERVED. TITLE <b>DIMENSION PRINT, 90/120 REOZT4</b> SCALE 0.05   CAD NO.   SHEET 2 of 3 DWG NO. <b>ADV-9175</b>
APPROVALS		DATE		
DRAWN		TKK 23SEP2019		
CHECKED		GFR 23SEP2019		
APPROVED		AJW 23SEP2019		

CENTER OF GRAVITY DIMENSIONS			WEIGHT DRY KG [LBS]	WEIGHT WET KG [LBS]
MODEL	CG X	CG Y		
90REOZT4	1643 [64.7]	594 [23.4]	2574 [5675]	2621 [5780]
120REOZT4	1658 [65.3]	600 [23.6]	2692 [5935]	2740 [6040]

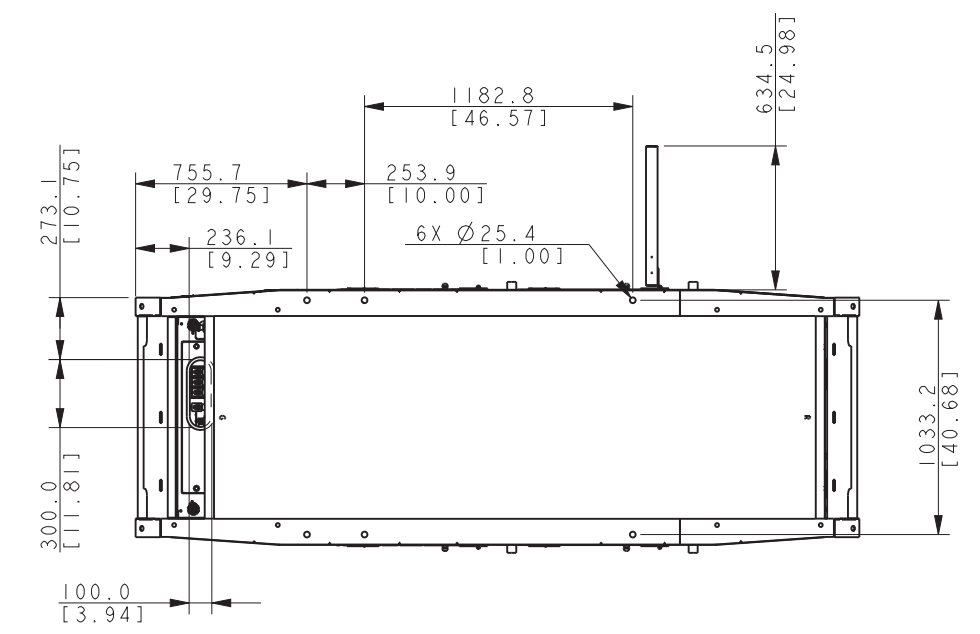
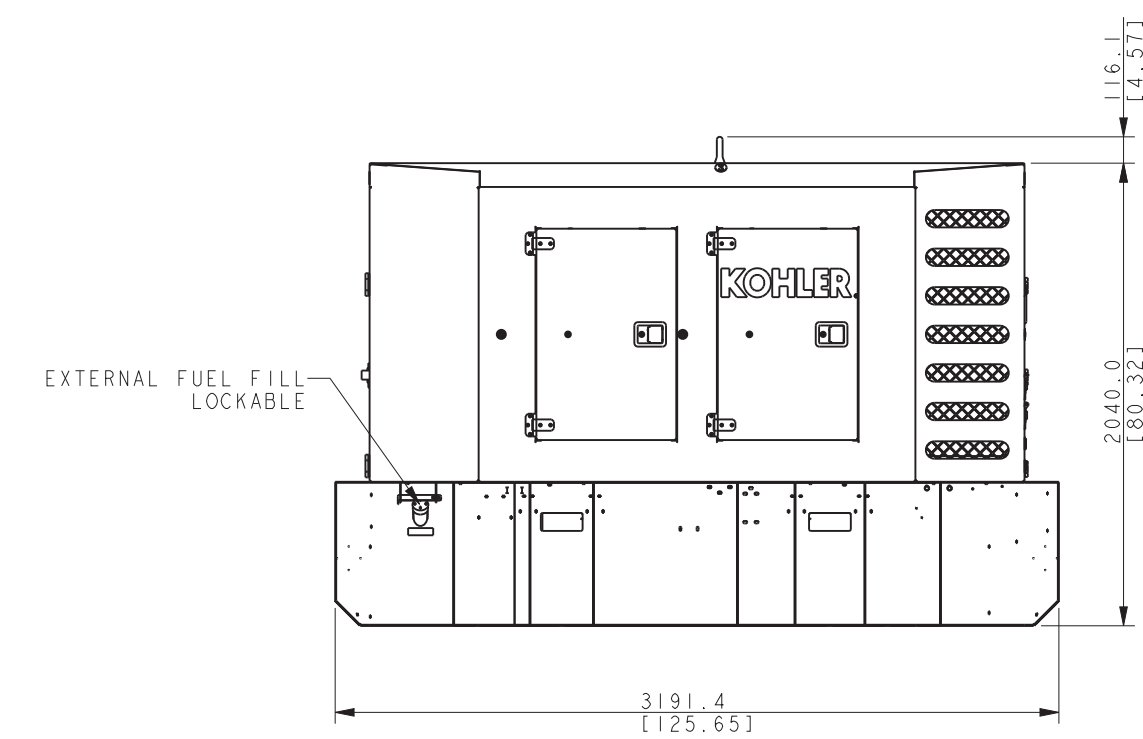
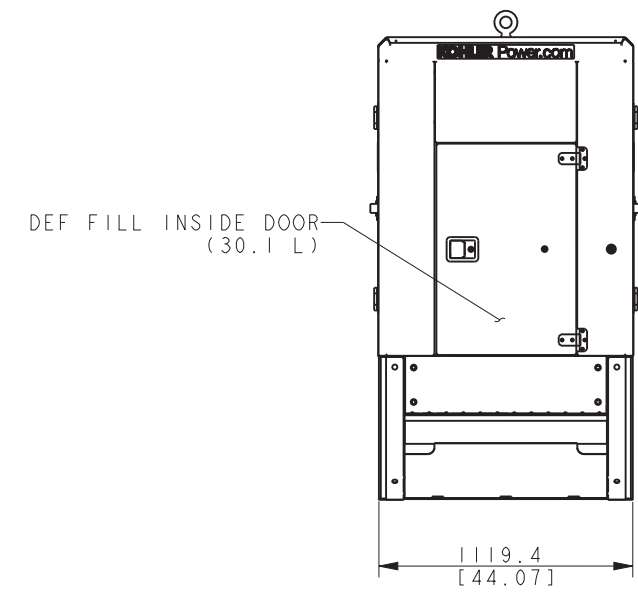
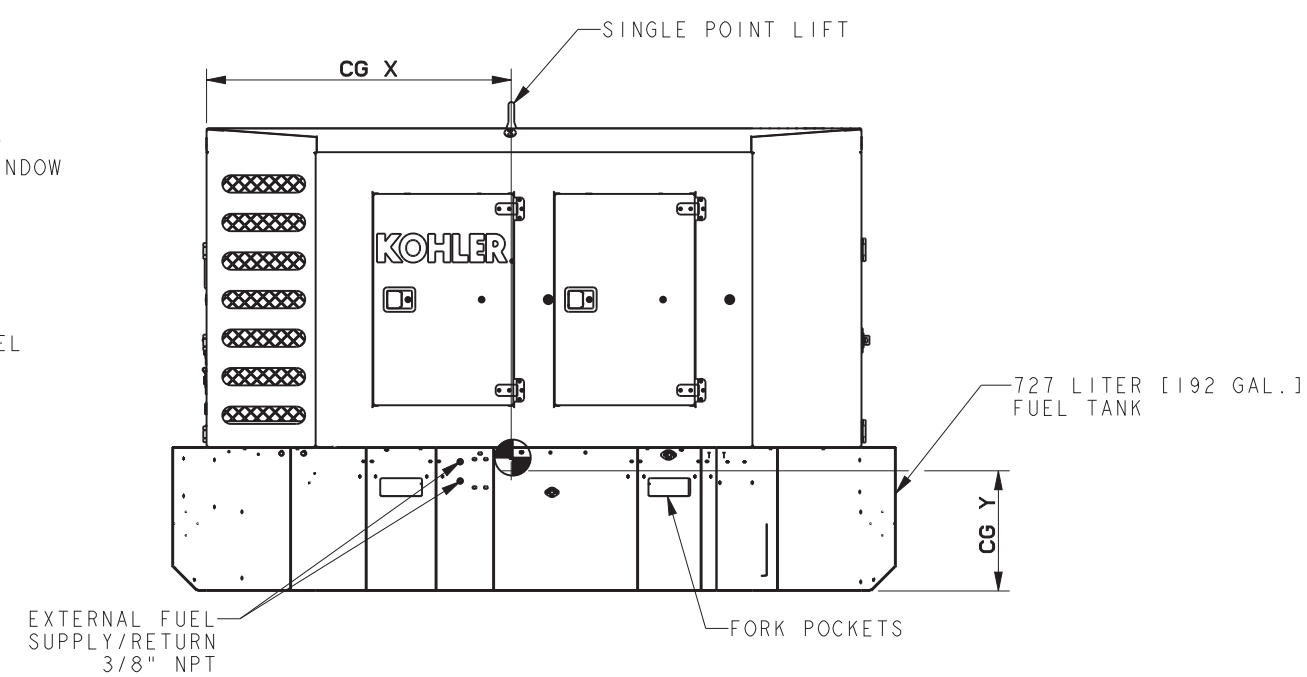
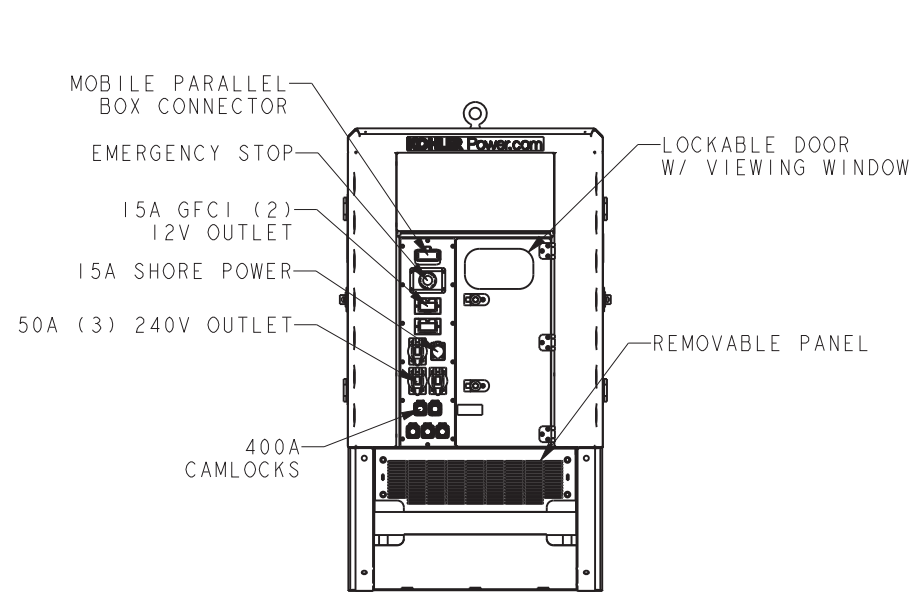

ENCLOSURE BOTTOM VIEW  
TANK VIEW REMOVED FOR CLARITY

FIELD DRAGGABLE

REV	DATE	ON COMPOSITE DWGS, SEE PART NO. FOR REVISION LEVEL	BY	DO NOT SCALE. REFERENCE THE MODEL FOR ALL UNSPECIFIED DIMENSIONS
-	23SEP2019	NEW DRAWING [CT198480]	TKK	UNLESS OTHERWISE SPECIFIED: ALL DIMENSIONS IN MILLIMETERS GENERAL TOLERANCES: XX ± 0.25 X ± 1.0 SURFACE FINISH X ± 1.5 MAX. ANGLES ± 0°30'
A	14OCT2020	SEE SHEET 1 [CT207348]	PAR	
				<b>KOHLER</b> KOHLER, WISCONSIN 53044 THIS DRAWING IN DESIGN AND DETAIL IS KOHLER CO. PROPERTY AND MUST NOT BE USED EXCEPT IN CONNECTION WITH KOHLER CO. WORK. ALL RIGHTS OF DESIGN OR INVENTION ARE RESERVED. TITLE <b>DIMENSION PRINT, 90/120 REOZT4</b> SCALE 0.06 CAD NO. SHEET 3 of 3 DWG NO. <b>ADV-9175</b>
APPROVALS		DATE		
DRAWN		TKK		23SEP2019
CHECKED		GFR		23SEP2019
APPROVED		AJW		23SEP2019