

KOHLER® KD 425-2



KOHLER
ENGINES

REGISTRATION OF MODIFICATIONS TO THE DOCUMENT

Any modifications to this document must be registered by the drafting body, by completing the following table.

Drafting body	Document code	Model N°	Edition	Revision	Issue date	Review date	Endorsed
CUSE/ATLO <i>M. Primella</i>	ED0053029360	51264	1°	0	04/07/2012	04/07/2012	<i>Fell...</i>



KD 425-2

PREFACE

- Every attempt has been made to present within this service manual, accurate and up to date technical information. However, development on the **KOHLER** series is continuous. Therefore, the information within this manual is subject to change without notice and without obligation. The materials used by **KOHLER** to construct the engine's components undergo strict quality controls and the engine's assembly guarantees reliability and long life. The engine has been built to the machine manufacturer's specifications, and it was its responsibility to adopt all the measures needed to meet the essential health and safety requirements as provided for by the laws in force; use of the engine for uses other than the one defined shall not be considered as compliant with the use intended by **KOHLER**, who therefore refuses all responsibility for any injury arising from such an operation.
 - The information contained within this service manual is the sole property of **KOHLER**. As such, no reproduction or replication in whole or part is allowed without the express written permission of **KOHLER**.
- Information presented within this manual assumes the following:
- 1 - The person or people performing service work on **KOHLER** series engines is properly trained and equipped to safely and professionally perform the subject operation;
 - 2 - The person or people performing service work on **KOHLER** series engines possesses adequate hand and **KOHLER** special tools to safely and professionally perform the subject service operation;
 - 3 - The person or people performing service work on **KOHLER** series engines has read the pertinent information regarding the subject service operations and fully understands the operation at hand.
- This manual was written by the manufacturer to provide technical and operating information to authorised **KOHLER** after-sales service centres to carry out assembly, disassembly, overhauling, replacement and tuning operations.
 - As well as employing good operating techniques and observing the right timing for operations, operators must read the information very carefully and comply with it scrupulously.
 - Time spent reading this information will help to prevent health and safety risks and financial damage. Written information is accompanied by illustrations in order to facilitate your understanding of every step of the operating phases.

LIMITED 3 YEAR KOHLER® DIESEL ENGINE WARRANTY

Kohler Co. warrants to the original retail consumer that each new KOHLER Diesel engine sold by Kohler Co. will be free from manufacturing defects in materials or workmanship in normal service for a period of three (3) years or 2000 hours whichever occurs first from the date of purchase, provided it is operated and maintained in accordance with Kohler Co.'s instructions and manuals. If no hour meter is installed as original equipment then 8 hours of use per day and 5 days per week will be used to calculate hours used.

Our obligation under this warranty is expressly limited, at our option, to the replacement or repair at Kohler Co., Kohler, Wisconsin 53044, or at a service facility designated by us of such parts as inspection shall disclose to have been defective.

This warranty does not apply to defects caused by unreasonable use, including faulty repairs by others and failure to provide reasonable and necessary maintenance.

The following items are not covered by this warranty:

Engine accessories such as fuel tanks, clutches, transmissions, power-drive assemblies and batteries, unless supplied or installed by Kohler Co. These are subject to the warranties, if any, of their manufacturers.

KOHLER CO. AND/OR THE SELLER SHALL NOT BE LIABLE FOR SPECIAL, INDIRECT, INCIDENTAL OR CONSEQUENTIAL DAMAGES OF ANY KIND, including but not limited to labor costs or transportation charges in connection with the repair or replacement of defective parts.

IMPLIED OR STATUTORY WARRANTIES, INCLUDING WARRANTIES OF MERCHANTABILITY OR FITNESS FOR A PARTICULAR PURPOSE, ARE EXPRESSLY LIMITED TO THE DURATION OF THIS WRITTEN WARRANTY. We make no other express warranty, nor is any one authorized to make any on our behalf.

Some states do not allow limitations on how long an implied warranty lasts, or the exclusion or limitation of incidental or consequential damages, so the above limitation or exclusion may not apply to you.

This warranty gives you specific legal rights, and you may also have other rights, which vary from state to state.

To obtain warranty service

Purchaser must bring the engine to an authorized Kohler service facility. To locate the nearest facility, visit our website, www.kohlerengines.com, and use the locator function, consult your Yellow Pages or telephone 1-800-544-2444.

ENGINE DIVISION, KOHLER CO., KOHLER, WISCONSIN 53044

**CALIFORNIA EMISSION CONTROL WARRANTY STATEMENT
YOUR WARRANTY RIGHTS AND OBLIGATIONS**

The California Air Resources Board and Kohler Co. are pleased to explain the **emission control system warranty** on your 2012 engine. In California, new heavy-duty off-road engines must be designed, built and equipped to meet the State's stringent anti-smog standards. Kohler Co. must warrant the emission control system on your engine for the time period listed below provided there has been no abuse, neglect or improper maintenance of your engine.

Your emission control system may include parts such as the fuel-injection system and the air induction system. Also included may be hoses, connectors and other emission related assemblies.

Where a warrantable condition exists, Kohler Co. will repair your heavy-duty off-road engine at no cost to you including diagnosis, parts and labor.

MANUFACTURER'S WARRANTY COVERAGE:

Your off-road, diesel engine emission control system is covered under warranty for a period of five (5) years or 3,000 hours, whichever occurs first, beginning on the date the engine or equipment is delivered to an ultimate purchaser for all constant speed engines with maximum power $19 \leq kW < 37$ and rated speed less than 3,000 rpm, all variable speed engines with maximum power $19 \leq kW < 37$, and all variable or constant speed engines with maximum power greater than 37 kW. Your off-road, diesel engine emission control system on variable or constant-speed engines with maximum power less than 19 kW, and for constant speed engines with maximum power $19 \leq kW < 37$ and rated speed equal to or greater than 3,000 rpm is covered under warranty for a period of two (2) years or 1,500 hours, whichever occurs first. If any emission related part on your engine is defective, the part will be repaired or replaced by Kohler Co.

OWNER'S WARRANTY RESPONSIBILITIES:

As the heavy-duty off-road engine owner, you are responsible for the performance of the **required maintenance listed in your Kohler Co. owner's manual**. Kohler Co. recommends that you retain all receipts covering maintenance on your heavy-duty off-road engine, but Kohler Co. cannot deny warranty solely for the lack of receipts or for your failure to ensure the performance of all recommended scheduled maintenance.

As the heavy-duty off-road engine owner, you should however be aware that Kohler Co. may deny you warranty coverage if your heavy-duty off-road engine or emission control related component has failed due to abuse, neglect, improper maintenance or unapproved modifications.

Your engine is designed to operate on commercial diesel fuel (No. 1 or No. 2 low sulfur or ultra low sulfur diesel fuel) only. Use of any other fuel may result in your engine no longer operating in compliance with California's emissions requirements.

You are responsible for initiating the warranty process. The Air Resources Board suggests that you present your heavy-duty off-road engine to a Kohler Co. dealer as soon as a problem exists. The warranty repairs should be completed by the dealer as expeditiously as possible.

Please review the document titled, "Kohler Co. Federal and California Emission Control Systems Limited Warranty Off-Road Diesel Engines", for complete details of your heavy-duty off-road engine warranty. If you have any questions regarding your warranty rights and responsibilities or the location of the nearest Kohler Co. authorized service location, you should contact Kohler Co. at 1-800-544-2444 or access our website at www.kohlerengines.com.

INDEX

WARRANTY CERTIFICATE	3
Limited 3 year kohler® diesel engine warranty	3
California emission control warranty statement	3
Your warranty rights and obligations	3
I - TROUBLE SHOOTING	7
Possible causes and trouble shooting	7
II - SAFETY AND WARNING DECALS - SAFETY INSTRUCTIONS.....	8
Safety regulations	8
General safety during operating phases	9
Safety and environmental impact	9
III - MODEL NUMBER AND IDENTIFICATION	10
The identification plate shown in the figure can be found directly on the engine.....	10
Approval data.....	10
IV - TECHNICAL DATA	11
V - CHARACTERISTICS.....	12
Characteristics power, torque and specific fuel consumption curves	12
VI - OVERALL DIMENSIONS	13
VII - SPECIAL TOOLS.....	14
VIII - MAINTENANCE - RECOMMENDED OIL TYPE - REFILLING	15
Manutenance	15
Fuel	15
Recommended oil.....	16
Acea sequences	16
IX - DISASSEMBLY OF THE ENGINE.....	17
Extracting fuel injectors	17
Removing the flywheel.....	17
Extraction of flywheel side main bearing.....	17
Extraction of crankshaft gear.....	17
Extraction of the camshaft gear.....	18
Extracting crankcase bushes	18
Extracting the oil pressure indicator plug	18
X - CHECKS AND OVERHAUL.....	19
Cylinders heads	19
Valves - Guides - Seats	19
Valves and springs.....	21
Rocker arms.....	21
Cylinders.....	21
Piston rings - Pistons - Piston pins	22
Connecting rods.....	22
Crankshaft.....	23
Checking crankshaft dimensions.....	23
Oil seal rings	24
Camshaft.....	24
Tappets and push rods	25



Injection pump plug nuts and control rods..... 25
 Fuel pump push-rod..... 25
 Oil pump..... 25
 Governor lever and spring 26

XI - INJECTION EQUIPMENT 27

Fuel circuit..... 27
 Injection pumps..... 27
 Checking injection pumps..... 27
 Injection pump setting..... 27
 Assembly of injection pumps 27
 Testing air tightness..... 28
 Injectors 29
 Checking and setting the injectors 29
 Disassembly and re-assembly of injectors..... 29

XII - ELECTRICAL EQUIPMENT 30

Plant specifications 30
 Checking electrical equipment 30
 Checking the alternator..... 30

XIII - ENGINE ASSEMBLY 31

Preparing the crankcase..... 31
 Central main bearings..... 31
 Crankshaft..... 32
 Main bearings - flywheel side 32
 Crankshaft end float..... 32
 Camshaft..... 33
 Governor tie rod adjustment 33
 Oil pump..... 34
 Timing cover 34
 Pulley and flywheel..... 34
 Pistons 35
 Connecting rods..... 35
 Cylinders..... 35
 Checking injector protrusion 36
 Cylinder heads..... 36
 Valve clearance 36
 Injection pumps..... 36
 Injection check..... 37
 Injectors and injector pipes..... 38
 Oil filter..... 38
 Feed pump..... 38
 Electric shut off 38

XIV - ENGINE TESTING..... 39

Speed adjustment 39
 Checking oil pressure 39
 Checking for oil leaks..... 39
 Dyno testing of engine 39
 Running-in table..... 40

XV - STORAGE 41

Storage 41
 How to prepare the engine for operation 41

XVI - QUICK REFERENCE CHARTS 42

Couplings 42
 Adjustments 42
 Tightening torques 43
 Standard screw tightening torques..... 43



POSSIBLE CAUSES AND TROUBLE SHOOTING

The following table contains the possible causes of some failures which may occur during operation. Always perform these simple checks before removing or replacing any part.

POSSIBLE CAUSE		TROUBLE									
		Engine does not start	Engine starts but stops	No acceleration	Non-uniform speed	Black smoke	White smoke	Too low oil pressure	Increase oil level	Excessive oil consumption	Oil and fuel dripping from exhaust
FUEL CIRCUIT	Clogged pipes	●		●							
	Clogged fuel filter	●	●	●			●				
	Air inside fuel circuit	●	●	●	●		●				
	Clogged tank breather hole	●	●	●							
	Faulty fuel pump	●	●								
	Injector jammed	●									
	Jammed injection pump delivery valve	●									
	Wrong injector setting					●				●	
	Excessive plunger blow-by	●				●		●			
	Jammed injection pump delivery control	●		●	●						
Wrong injection pump setting		●	●	●	●						
LUBRICATION	Oil level too high				●		●		●		
	Jammed pressure relief valve							●			
	Worn oil pump							●			
	Air inside oil suction pipe							●			
	Faulty pressure gauge or switch							●			
Clogged oil suction pipe							●				
ELECTRIC SYSTEM	Battery discharged	●									
	Wrong or inefficient cable connection	●									
	Defective ignition switch	●									
	Defective starter motor	●									
MAINTENANCE	Clogged air filter	●		●		●			●		
	Excessive idle operation						●		●	●	
	Incomplete running-in						●		●	●	
	Engine overloaded	●	●	●		●					
SETTINGS/REPAIRS	Advanced injection	●									
	Delayed injection	●				●	●				
	Incorrect governor linkage adjustment	●			●						
	Broken or loose governor spring		●	●							
	Idle speed too low		●		●						
	Worn or jammed piston rings						●		●	●	
	Worn or scored cylinders						●		●	●	
	Worn valve guides						●		●	●	
	Jammed valves	●									
	Worn bearings							●			
	Governor linkage not free to slide	●	●		●						
	Drive shaft not free to slide					●					
Damaged cylinder head gasket	●										

SAFETY REGULATIONS

GENERAL NOTES

- **Kohler** engines are built to provide safe and longlasting performances, but in order to obtain these results it is essential that the maintenance requirements described in the manual are observed along with the following safety recommendations.
- The engine has been built to the specifications of a machine manufacturer, and it is his responsibility to ensure that all necessary action is taken to meet the essential and legally prescribed health and safety requirements. Any use of the machine other than that described cannot be considered as complying with its intended purpose as specified by **Kohler**, which therefore declines all responsibility for accidents caused by such operations.
- The following instructions are intended for the user of the machine in order to reduce or eliminate risks, especially those concerning the operation and standard maintenance of the engine.
- The user should read these instructions carefully and get to know the operations described. By not doing so he may place at risk his own health and safety and that of anyone else in the vicinity of the machine.
- The engine may be used or mounted on a machine only by personnel suitably trained in its operation and aware of the dangers involved. This is particularly true for standard and, above all, special maintenance work. For special maintenance contact personnel trained specifically by **Kohler**. This work should be carried out in accordance with existing literature.
- **Kohler** declines all responsibility for accidents or for failure to comply with the requirements of law if changes are made to the engine's functional parameters or to the fuel flow rate adjustments and speed of rotation, if seals are removed, or if parts not described in the operating and maintenance manual are removed and reassembled by unauthorized personnel.



WARNING

- In addition to all other machine specifications, ensure that the engine is in a near horizontal position when starting. If starting manually, ensure that the necessary operations can be performed without any risk of striking against walls or dangerous objects. Rope starting (except for recoil rope starting) is not permitted even in emergencies.
- Check that the machine is stable so that there is no risk of it overturning.
- Get to know the engine speed adjustment and machine stop operations.
- Do not start the machine in closed or poorly ventilated environments. The internal combustion process generates carbon monoxide, an odourless and highly toxic gas, so spending too long a time in an environment where the engine discharges its exhaust products freely can lead to loss of consciousness and even death.
- The engine may not be used in environments containing flammable materials, explosive atmospheres or easily combustible powders, unless adequate and specific precautions have been taken and are clearly stated and certified for the machine.
- To prevent the risk of fire, keep the machine at a distance of at least one metre from buildings or other machines.

- Children and animals must be kept at a sufficient distance from the machine to prevent any danger resulting from its operation.
- Fuel is flammable, so the tank must be filled only when the engine is turned off. Dry carefully any fuel that may have spilled, remove the fuel container and any cloths soaked in fuel or oil, check that any sound-absorbing panels made of porous material are not soaked with fuel or oil, and make sure that the ground on which the machine is located has not absorbed fuel or oil.
- Before starting, remove any tools that have been used for carrying out maintenance work to the engine and/or the machine and check that any guards removed have been replaced. In cold climates it is possible to mix kerosene with the diesel fuel to make the engine easier to start. The liquids must be mixed in the tank by pouring in first the kerosene and then the diesel fuel. Consult **Kohler** technical office for mixture proportions. Petrol may not be used because of the risk of it forming flammable vapours.
- During operation the surface of the engine reaches temperatures that may be dangerous. Avoid in particular all contact with the exhaust system.
- The liquid cooling circuit is under pressure. Do not carry out any checks before the engine has cooled down, and even then open the radiator cap or the expansion tank cautiously. Wear protective clothing and glasses. If there is an electric fan, do not approach the engine while it is still hot as the fan may come on even when the engine is not running. Clean the cooling system with the engine turned off.
- While cleaning the oil bath air filter, check that the oil is disposed of in such a way as not to harm the environment. Any filtering sponges in the oil bath air filter should not be soaked with oil. The cyclone pre-filter cup must not be filled with oil.
- Since the oil must be emptied out while the engine is still hot (approx. 80°C), particular care should be taken in order to avoid burns. In any case make sure that oil does not come into contact with your skin because of the health hazards involved.
- Fuel vapours are highly toxic, so fill up only in the open air or in well ventilated environments.
- During operations which involve access to moving parts of the engine and/or removal of the rotary guards, disconnect and insulate the positive cable of the battery so as to prevent accidental short circuits and activation of the starter motor.
- Check the belt tension only when the engine is turned off.



IMPORTANT

- To start the engine follow the specific instructions provided in the engine and/or machine operating manual. Do not use auxiliary starting devices not originally installed on the machine (e.g. Startpilot systems which utilise ether etc.)
- Before carrying out any work on the engine, turn it off and allow it to cool down. Do not perform any operation while the engine is running.
- Check that the discharged oil, the oil filter and the oil contained in the oil filter are disposed of in such a way as not to harm the environment.
- Close the fuel tank filler cap carefully after each filling operation. Do not fill the tank right up to the top, but leave sufficient space to allow for any expansion of the fuel.

- . Do not smoke or use naked flames while filling.
- . Take care when removing the oil filter as it may be hot.
- . The operations of checking, filling up and replacing the cooling liquid must be carried out with the engine turned off and cold. Take particular care if liquids containing nitrites are mixed with others not containing these compounds as this may give rise to the formation of nitrosamines which are a health hazard. The cooling liquid is polluting, so dispose of in a manner that does not damage the environment.
- . In order to move the engine simultaneously use the eyebolts fitted for this purpose by **Kohler**. These lifting points are however not suitable for the entire machine, so in this case use the eyebolts fitted by the manufacturer.

GENERAL SAFETY DURING OPERATING PHASES

- The procedures contained in this manual have been tested and selected by the manufacturer's technical experts, and hence are to be recognised as authorised operating methods.
- Some tools are normal workshop ones, while others are special tools designed by the Manufacturer of the engine.
- All tools must be in good working condition so that engine components are not damaged and that operations are carried out properly and safely.
- It is important to wear the personal safety devices prescribed by work safety laws and also by the standards of this manual.
- Holes must be lined up methodically and with the aid of suitable equipment. Do not use your fingers to carry out this operation to avoid the risk of amputation.
- Some phases may require the assistance of more than one operator. If so, it is important to inform and train them regarding the type of activity they will be performing in order to prevent risks to the health and safety of all persons involved.
- Do not use flammable liquids (petrol, diesel, etc.) to degrease or wash components. Use special products.
- Use the oils and greases recommended by the manufacturer. Do not mix different brands or combine oils with different characteristics.
- Discontinue use of the engine if any irregularities arise, particularly in the case of unusual vibrations.
- Do not tamper with any devices to alter the level of performance guaranteed by the manufacturer.

SAFETY AND ENVIRONMENTAL IMPACT

Every organisation has a duty to implement procedures to identify, assess and monitor the influence of its own activities (products, services, etc.) on the environment.

Procedures for identifying the extent of the impact on the environment must consider the following factors:

- Liquid waste;
- Waste management;
- Soil contamination;
- Atmospheric emissions;
- Use of raw materials and natural resources;
- Regulations and directives regarding environmental impact.

In order to minimise the impact on the environment, the manufacturer now provides a number of indications to be followed by all persons handling the engine, for any reason, during its expected lifetime.

- All packaging components must be disposed of in accordance with the laws of the country in which disposal is taking place.
- Keep the fuel and engine control systems and the exhaust pipes in efficient working order to limit environmental and noise pollution.
- When discontinuing use of the engine, select all components according to their chemical characteristics and dispose of them separately.

California Proposition 65 WARNING

Engine exhaust from this product contains chemicals known to the State of California to cause cancer, birth defects, or other reproductive harm.

The identification plate shown in the figure can be found directly on the engine.

It contains the following information:

- A) Manufacturer's identity
- B) Engine type
- C) Engine serial number
- D) Maximum operating speed
- E) Number of the customer version (form K)
- F) Approval data

Approval data

The approval reference directives EC are on the engine plate (F).

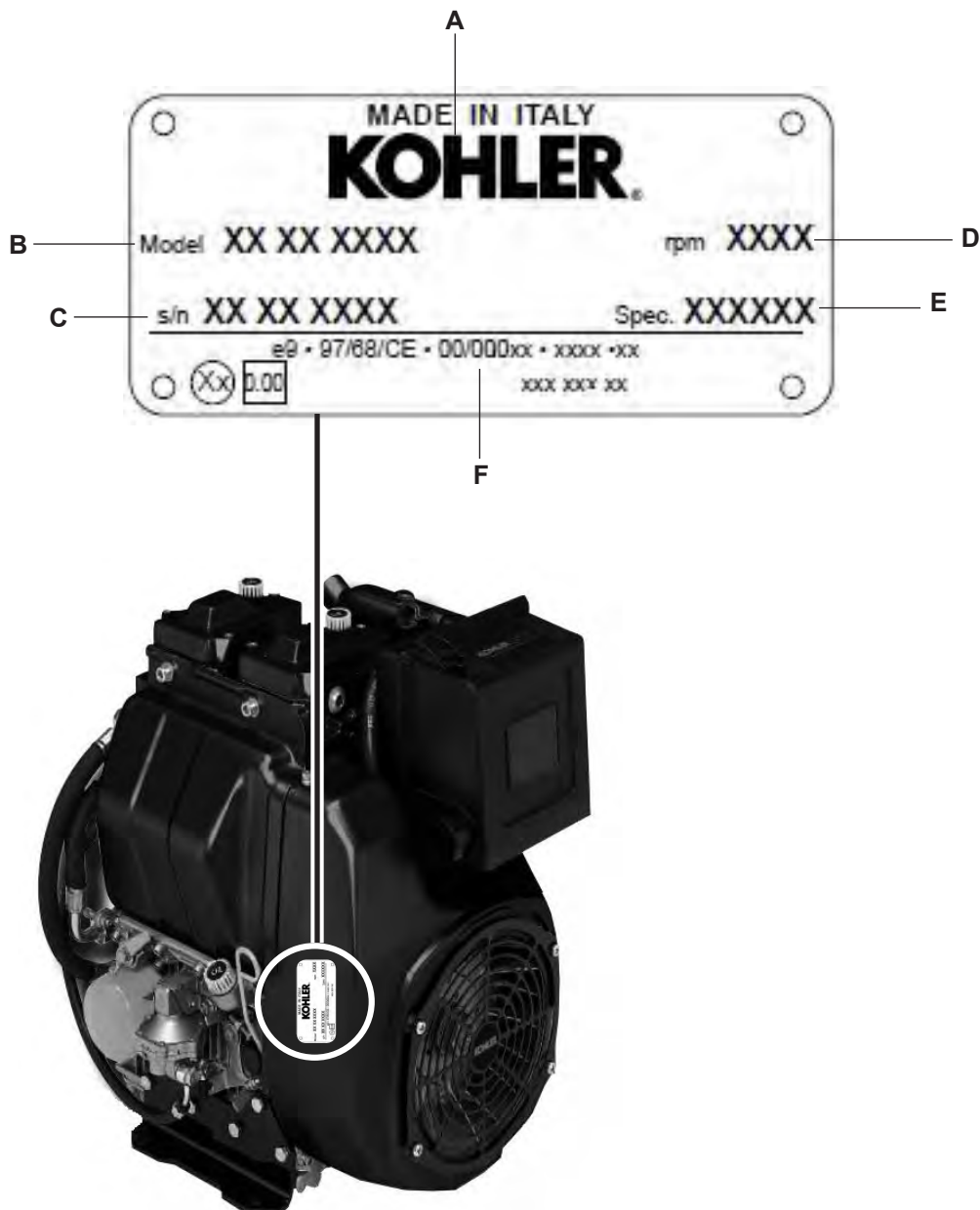

CHARACTERISTICS

ENGINE TYPE			KD 425-2
Number of cylinders	N.		2
Bore	mm		85
Stroke	mm		75
Swept volume	cm ³		851
Compression ratio			19:1
Power kW (HP)	N 80/1269/CEE-ISO 1585	@ 3000 RPM	12,5(17)
		@ 3600 RPM	14(19)
	NB ISO 3046 - 1 IFN	@ 3000 RPM	11,4(15,5)
		@ 3600 RPM	13(17,7)
	NA ISO 3046 - 1 ICXN	@ 3000 RPM	10,5(14,3)
		@ 3600 RPM	12(16,5)
Max. torque *	Nm		40,5@2400
Fuel consumption **	g/kW.h		246
Oil consumption	g/kW.h		0,8
Capacity of standard oil sump	lt		1,8
Recommended battery 12V	Ah -A		66-300
Dry weight	kg		53
Combustion air volume	m ³ /h		75
Cooling air volume	m ³ /h		750
Max. permissible driving shaft axial: continuous (instantaneous)	kg.		100(300)
Max. inclination	Flywheel site: continuous (instantaneous)		25°(30°)
	Power take off site: continuous (instantaneous)		25°(35°)
	Lateral: continuous (instantaneous)		25°(40°)

* Referred to N power

** Consumption at max torque

CHARACTERISTICS POWER, TORQUE AND SPECIFIC FUEL CONSUMPTION CURVES

KD 425-2

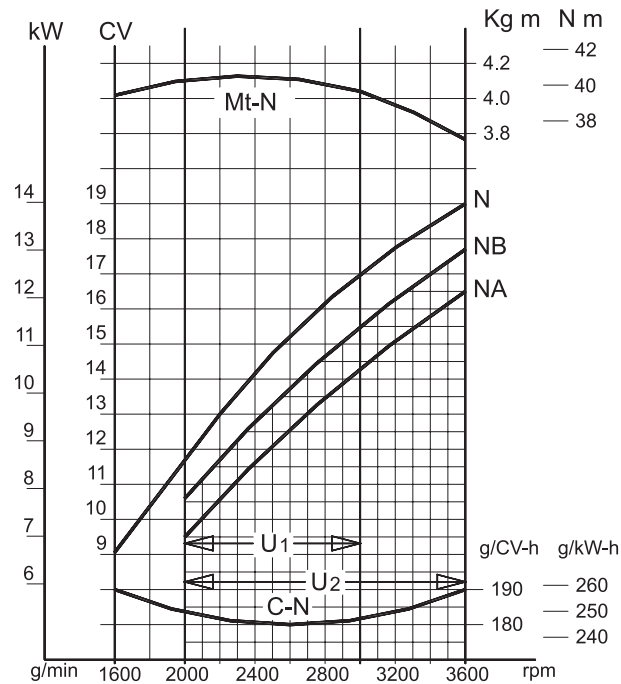

N (80/1269/EEC - ISO 1585)

NB (ISO 3046 - 1 IFN)

load.

NA (ISO 3046 - 1 ICXN)

constant load.

Mt-N Torque at N power.

C Specific fuel consumption at N power.

U1: Standard utilization range of engines rated at 3000 rpm

U2: Standard utilization range of engines rated at 3600 rpm

AUTOMOTIVE RATING : Intermittent operation with variable speed and variable load.

RATING WITH NO OVERLOAD CAPABILITY: continuous light duty operation with constant speed and variable load.

CONTINUOUS RATING WITH OVERLOAD CAPABILITY: continuous heavy duty with constant speed and constant load.

The above power values refer to an engine fitted with air cleaner and standard muffler, after testing and at the environmental conditions of 20°C and 1 bar.



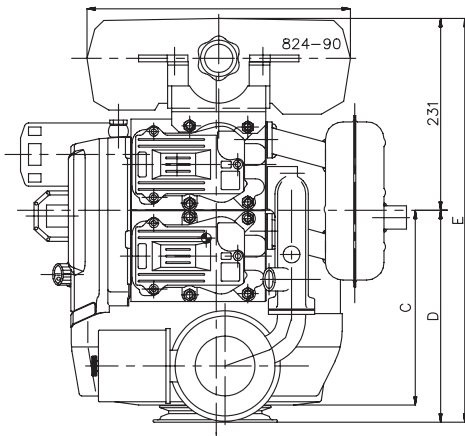
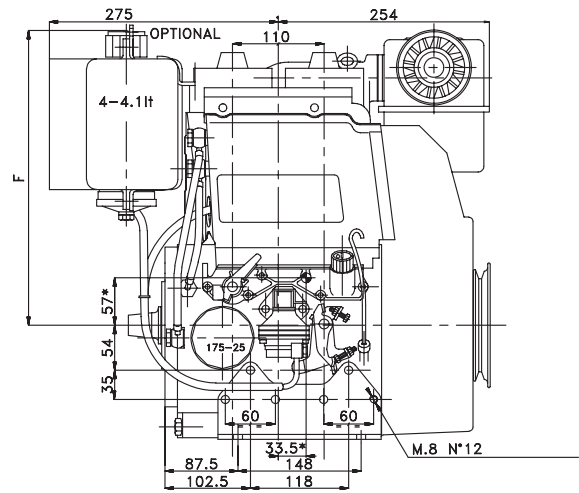
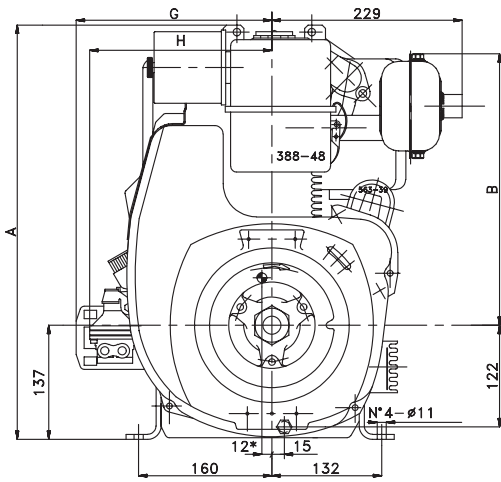

Max. power tolerance is 5%.

Power decreases by approximately 1% every 100 m di altitude and by 2% every 5°C above 25°C.

Note: Consult Kohler for power, torque curves and specific consumptions at rates differing from those given above.

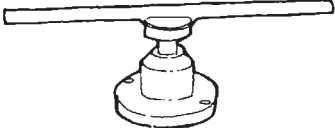
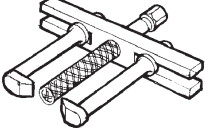
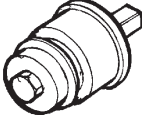
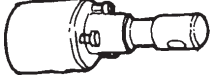

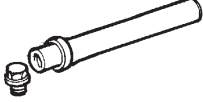
Note: Dimensions in mm

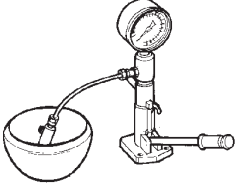
TOOL	CODE	DESCRIPTION
	00365R0020	Flywheel puller
	00365R0010	Universal puller
	00365R0900	Main bearing extractor
	00365R0890	Gear extractor
	00365R0910	Central bearing assembly tool
	00365R0930	Valve guide rubber fitting tool
	00365R0770	Cylinder collar Ø 80/85 mm
	00365R0940	Injection advance control tool
	00365R0430	Injector test bench



Failure to carry out the operations described in the table may lead to technical damage to the machine and/or system

MANUTENANCE

OPERATION	COMPONENT		INTERVAL (HOURS)							
			8	50	200	300	400	2500	5000	
CLEANING	OIL-BATH AIR CLEANER		(*)	●						
	HEAD AND CYLINDER FINS		(*)	●						
	INTERNAL OIL FILTER					●				
	FUEL TANK						●			
	INJECTOR						●			
CHECK	LEVEL	AIR CLEANER OIL		●						
		OIL SUMP		●						
		BATTERY FLUID			●					
	VALVE/ROCKER ARM CLEARANCE						●			
	INJECTOR SETTING						●			
REPLACEMENT	OIL	AIR CLEANER	(**)	●						
		SUMP	(**)(***)		□	●				
	INTERNAL OIL FILTER CARTRIDGE					●				
	EXTERNAL OIL FILTER CARTRIDGE							●		
	FUEL FILTER CARTRIDGE					●				
DRY AIR CLEANER CARTRIDGE					●					
OVERALL INSPECTION	PARTIAL		(x)							●
	COMPLETE		(xx)							

□ First replacement

(*) Under severe working conditions, clean daily.

(**) Under extremely dusty conditions, change every 4-5 hours.

(***) See recommended oil type.

(x) The partial overhaul includes the following operations: valve and seat lapping, injector and injection pump overhaul, injector projection check, fuel injection spark advance check, check of the harmful area between head and piston, camshaft and crankshaft end float check, tightening of bolts.

(xx) The general overhaul includes - in addition to all partial overhaul - the following procedures: cylinder and piston replacement, seat, guide and valve refacing, crankshaft replacement or grinding, bench bearing and connecting rod replacement.

The maintenance operations listed above refer to an engine operating in normal conditions (temperature, degree of humidity, dust in the working environment). They may vary significantly according to the type of use.



To avoid explosions or fire outbreaks, do not smoke or use naked flames during the operations. Fuel vapours are highly toxic. Only carry out the operations outdoors or in a well ventilated place.

Keep your face well away from the plug to prevent harmful vapours from being inhaled. Dispose of fuel in the correct way and do not litter as it is highly polluting.

FUEL

When refuelling, it is advisable to use a funnel to prevent fuel from spilling out. The fuel should also be filtered to prevent dust or dirt from entering the tank.

Use the same type of diesel fuel as used in cars. Use of other types of fuel could damage the engine. The cetane rating of the fuel must be higher than 45 to prevent difficult starting. Do not use dirty diesel fuel or mixtures of diesel fuel and water since this would cause serious engine faults.

The capacity of the standard tank is: lt. 4,0



The engine could be damaged if allowed to operate with insufficient oil. It is also dangerous to add too much oil as its combustion could sharply increase the rotation speed.

Use a suitable oil in order to protect the engine.

The lubrication oil influences the performances and life of the engine in an incredible way.

The risk of piston seizure, jammed piston rings and rapid wear of the cylinder liner, the bearings and all moving parts increases if oil whose characteristics differ from the recommended type is used, or if the oil is not regularly changed.

All this notably reduces engine life.

Oil viscosity must suit the ambient temperature in which the engine operates.



Old oil can cause skin cancer if repeatedly left in contact with the skin and for long periods of time. If contact with the oil is inevitable, you are advised to thoroughly wash your hands with soap and water as soon as possible.

Appropriate protective gloves etc should be wore during this operation.

Old oil is highly polluting and must be disposed of in the correct way. Do not litter.

RECOMMENDED OIL

AGIP SINT 2000 5W40 specification API SJ/CF ACEA A3-96 B3-96 MIL-L-46152 D/E.

ESSO ULTRA 10W40 specification API SJ/CF ACEA A3-96 MIL-L-46152 D/E.

In countries where AGIP and ESSO products are not available, use API SJ/CF oil for gasoline-fuelled engines or oil that complies with military specification MIL-L-46152 D/E.

**OIL SUPPLY (liters)
Standard oil sump**

filter included 1,8 l.

ACEA SEQUENCES

- A = Gasoline (Petrol)
- B = Light Diesel fuels
- E = Heavy Diesel fuels

Required levels :

- A1-96
- A2-96
- A3-96
- B1-96
- B2-96
- B3-96
- E1-96
- E2-96
- E3-96

GRADE

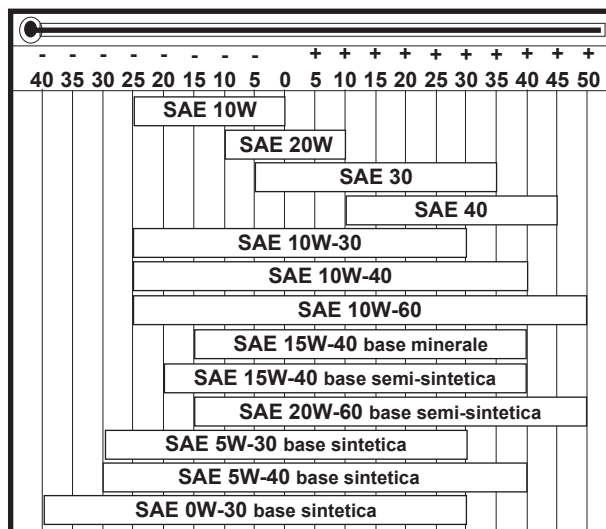

DIESEL						BENZINA - ESSENCE - PETROL BENZIN - GASOLINA									
API	CF	CE	CD	CC	CB	CA	SA	SB	SC	SD	SE	SF	SG	SH	SJ
							CCMC G- 2						G- 4		
							CCMC G- 3						G- 5		
							CCMC PD - 1 / PD - 2								
			D- 4	CCMC D- 2											
		D- 5	CCMC D- 3												
				MIL - L - 2104 D											
				MIL - L - 2104 E											
				MIL - L - 46152 C											
				MIL - L - 46152 D/E											
				MB 226.1									MB 226.5		
				MB 227.1									MB 227.5		
		228.3	MB 228.1												
				VW 500.00											
				VW 501.01											
				VW 505.00											
				VOLVO VDS											
				MAN QC 13-017											



During repair operations, when using compressed air, wear eye protection.

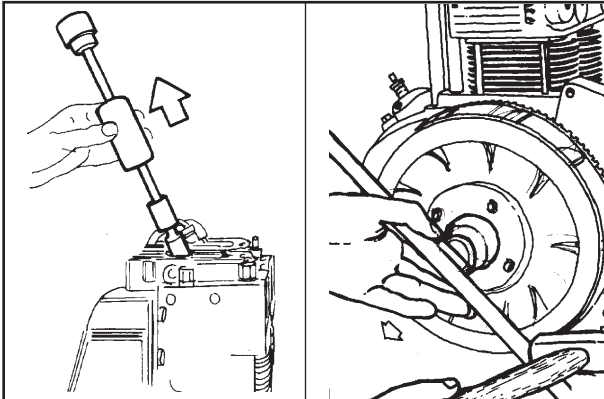

1

2

Extracting fuel injectors

Unscrew the fuel feeding pipes.
Remove the injectors using a commercial extractor tool as shown in fig. 1.

Removing the flywheel

Use the extractor number 00365R0020 as shown in figure 2.



During the demounting phases, pay particular attention to prevent the flywheel from dropping as this could seriously injure the operator.
Wear protective goggles when removing the flywheel ring.



IMPORTANT: Do not tap the end of the extractor when removing the flywheel.

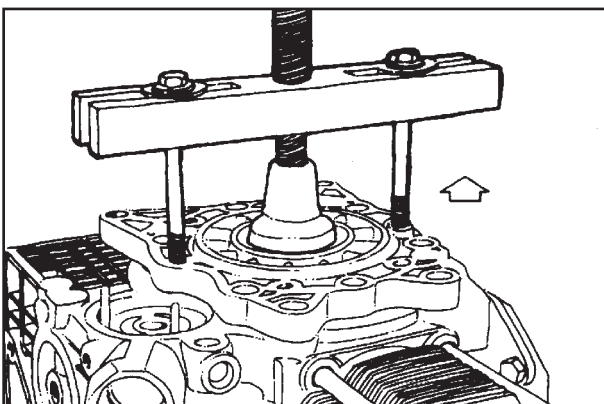

3

Extraction of flywheel side main bearing

Withdraw the bearing using two M8 screws taking care to tighten them evenly; alternatively use a commercial extractor, as shown in figure 3.

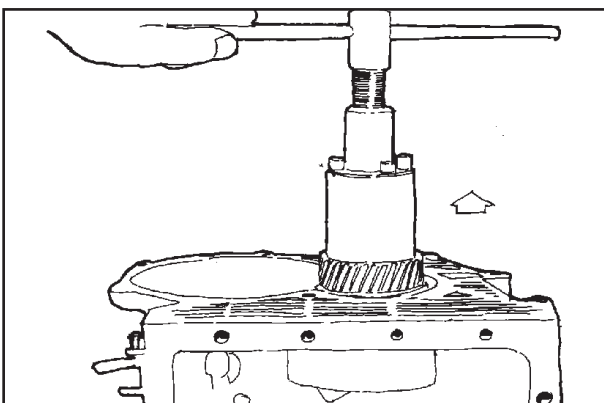

4

Extraction of crankshaft gear

Use extractor tool number 00365R0890 (fig.4).

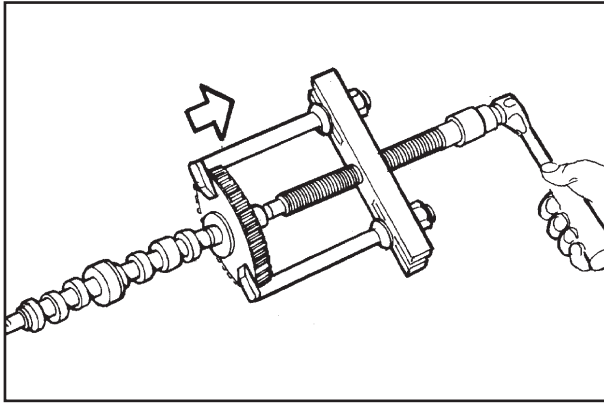

Extraction of the camshaft gear

Use the extractor number 00365R0010 (fig.5).

5

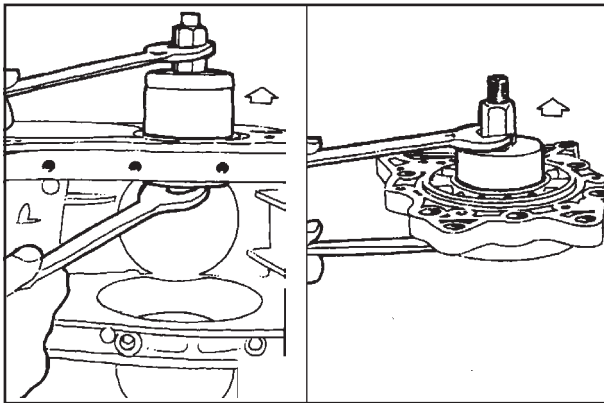

Extracting crankcase bushes

From crankcase (fig.6)

From main bearing (fig.7)

Use extractor number 00365R0900.

6

7

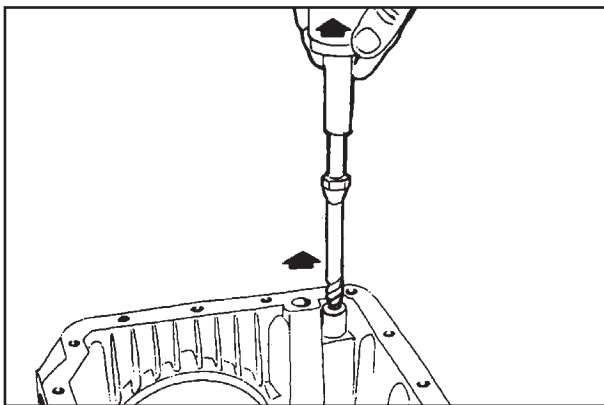

Extracting the oil pressure indicator plug

Loosen the plug securing screw, and remove circlip, spring and ball. Cut a thread on the inside of the plug body and then withdraw it using a commercial extractor tool (fig. 8).

8

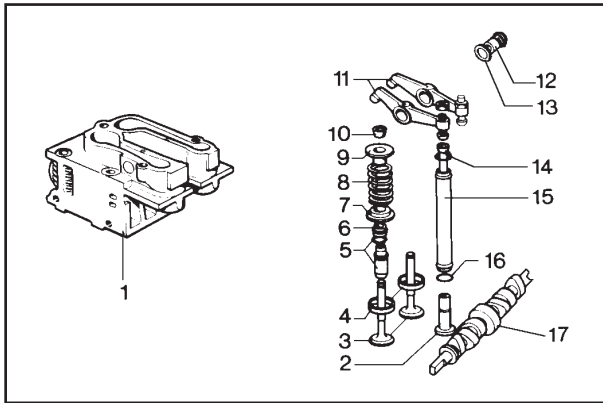

9

Cylinders heads

Parts shown in figure 9.

1.Head - 2.Tappets - 3.Valves - 4.Seats - 5.Guides - 6.Seals - 7.Lower washers - 8.Springs - 9.Top washers - 10.Valve locking split cones - 11.Rocker arms - 12.Rocker pins - 13.Gaskets - 14.Push rods - 15.Cover tube - 16.O-ring - 17.Camshaft.

The heads are made off aluminium with valve guides and seats are made of cast iron.



Do not disassemble the head when the engine is hot to avoid deformation.

Clean heads of carbon deposits and check the cylinder mating surfaces; if they are deformed they must be ground to a maximum of 0.3 mm. Check that there are no cracks or other imperfections in the heads. If defects are encountered the heads must be renewed. In this case consult the spare parts catalogue.

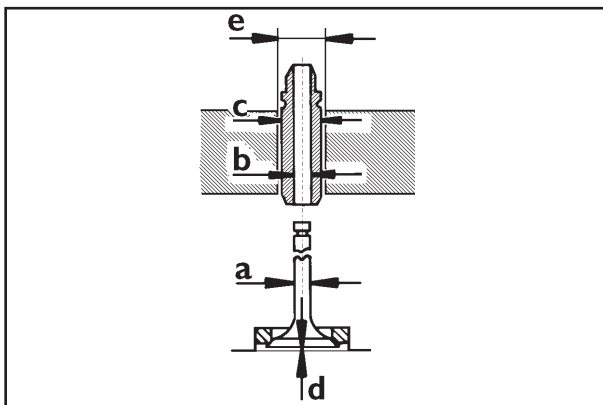

10

Valves - Guides - Seats

Clean the valves with a wire brush and renew them if the valve heads are deformed, cracked or worn.

Guide	a mm	b mm	c mm	d mm	e mm
Inlet	6,960+6,970	7,00+7,01	13,025+13,037	0,8+1,0	13+13,01
Exhaust	6,945+6,955	assembly			

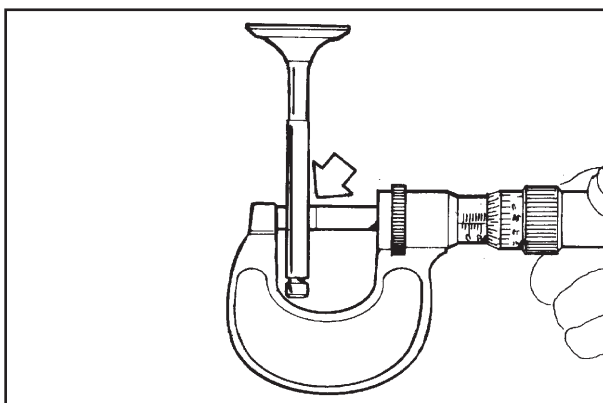

11

Check the dimensional conformity of the valve stems (fig. 11) and the clearance between valve and guide, bore out the guides to the dimensions indicated in the table (fig. 10).

Renew both guide and valve if the clearance is greater than 0.1mm.

It is always necessary to grind the valve seats when new guides are fitted.

Oversize valve guides with external diameter increased by 0.10 are available.

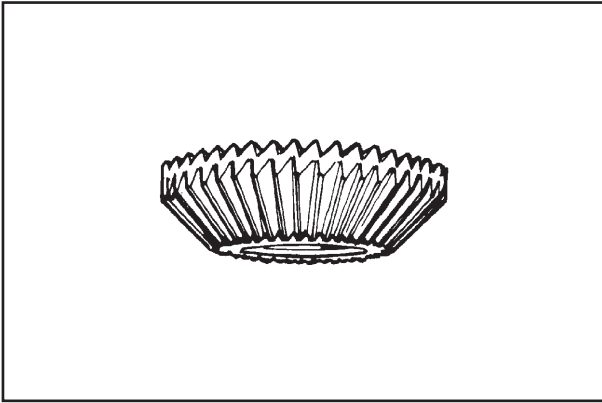

12

After prolonged running of the engine the hammering of the valves on their seats at high temperature tends to harden the faces of the seats and makes manual grinding difficult. It is necessary to remove the hardened surface with a 45° cutter (fig. 12).

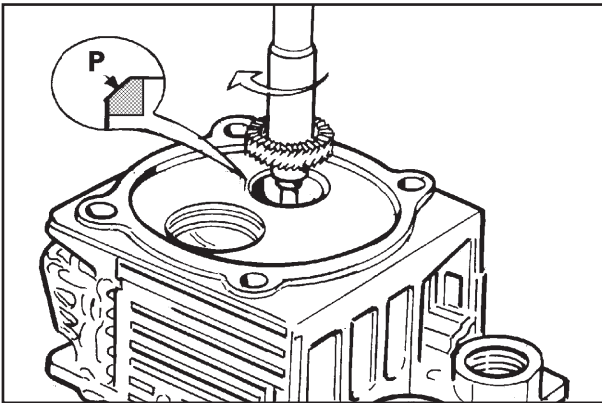

13

Grinding of valve seats causes a widening of the valve seat face **P** (fig.13). Final lapping of the valve on the seat must be carried out by coating the seat with a fine lapping compound and rotating the valve in a clockwise and counterclockwise direction with slight pressure until a perfect surface finish is obtained (fig.14).

Observe the valve seating clearances indicated in the following table (fig.10).

Fitting mm	Max. wear mm
d= 0,8 ±1,0	d=1,3

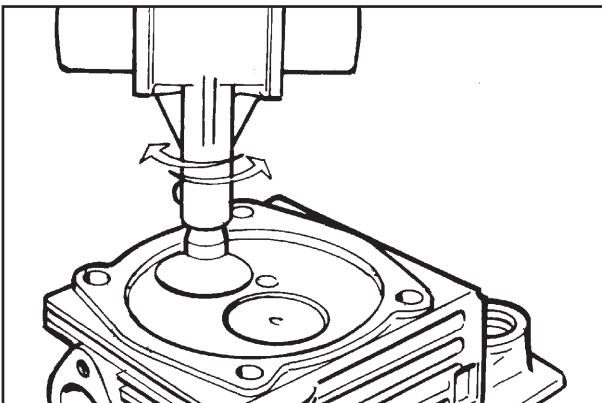

14



In the case of lower values the valve may strike the piston. In the case of values in excess of 1.3 mm the valve seat rings must be replaced.

Fitting of new seats or valves always requires preparatory grinding. Valves are available with the external diameter increased by 0.5 mm.

After grinding wash the valve and seat carefully with petrol or paraffin in order to remove residual grinding paste and chips. Once you have finished grinding check the efficiency of the seal between the valve and seat as outlined below:

1. Fit the valve on the head with spring, washers and split cones (fig.9).
2. Invert the head and pour in a few drops of diesel fuel or oil around the edges of the valve head.
3. Blow compressed air into the inlet of the cylinder head taking care to seal the edges so that the air does not escape (fig.15).

Should air bubbles form between the seat and the valve remove the valve and regrind the seat.

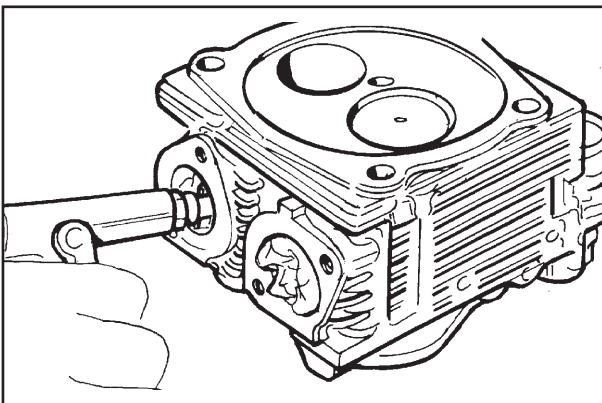

15

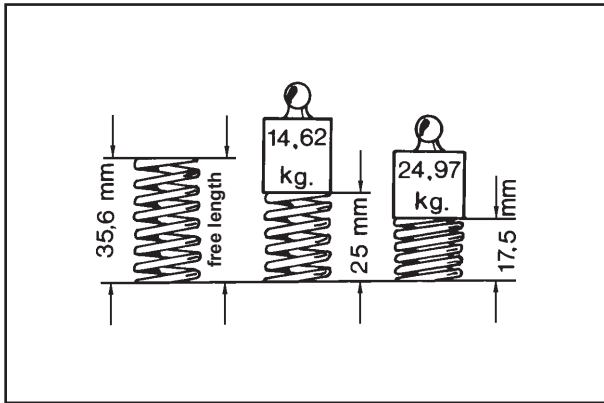

16

Valves and springs

In order to check the springs for possible failure measure the lengths under load as shown in figure 16.

The permissible tolerance for loads and lengths is $\pm 10\%$. If the figures measured do not fall within these values, the springs must be renewed.

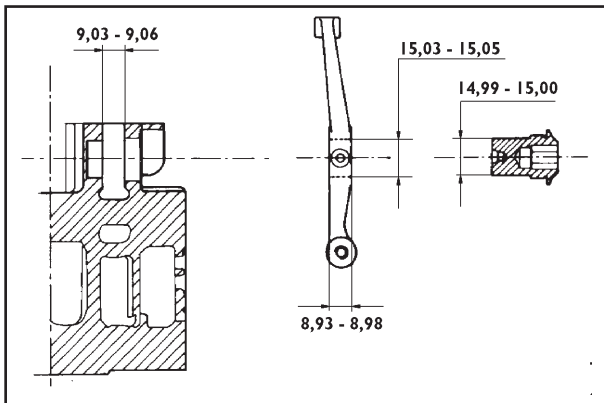

17

Rocker arms

Make sure that the facing surfaces between rocker and pin are not scored and show no signs of seizure. If such marks are encountered, renew rocker and pin. Rocker / pin clearance (fig.17):

Fitting mm	Max. wear mm
0,03 ÷ 0,06	0,15

Rocker axial play (fig.17):

Fitting mm	Max. wear mm
0,05 ÷ 0,130	0,5

Make sure that the rocker arm adjusting screw is not worn and that the lubrication hole is free of dirt.

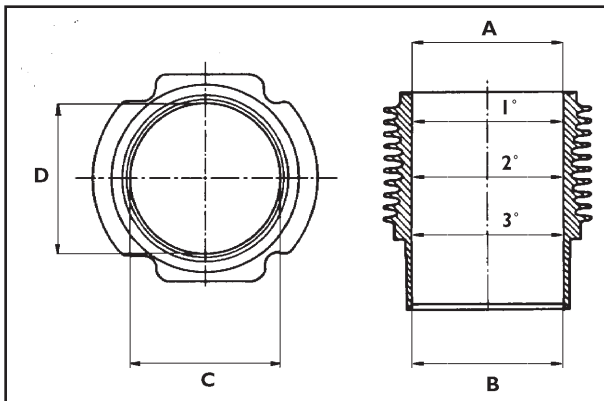

18

Cylinders

Air cooled with cylinder barrels in special cast iron with integral liners.

Use a dial gauge to check internal diameters (C-D) at three different heights (fig.18).

Maximum permitted taper (A-B) and ovality (C-D) is 0.06mm.

Diameter of cylinders (fig.18):

KD 425-2	$\varnothing 85 \div 85,015$
----------	------------------------------

If the diameter of the cylinder does not exceed said values or if there are slight surface scores on the cylinder, it will be sufficient to change the piston rings.

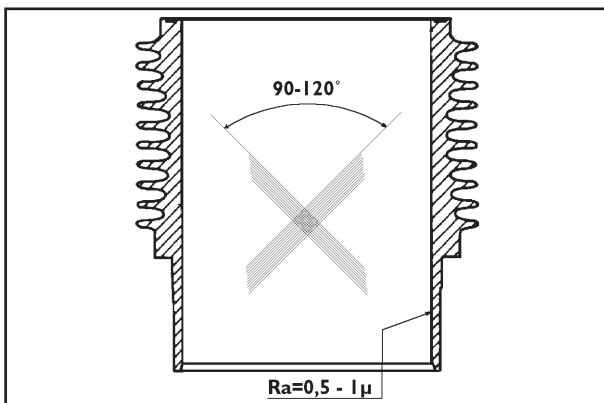

19



Do not manually hone the cylinder bore surfaces with emery cloth or other means.

The cross-hatch pattern should be at an angle of $90^\circ \div 120^\circ$; lines should be uniform and clear in both directions.

Average roughness must range between 0.5 mm $1 \mu\text{m}$.

The cylinder surface which comes into contact with piston rings should be machined with the plateau method.

If the taper and ovality of the cylinder exceed the values indicated, then the cylinder and piston must be renewed.

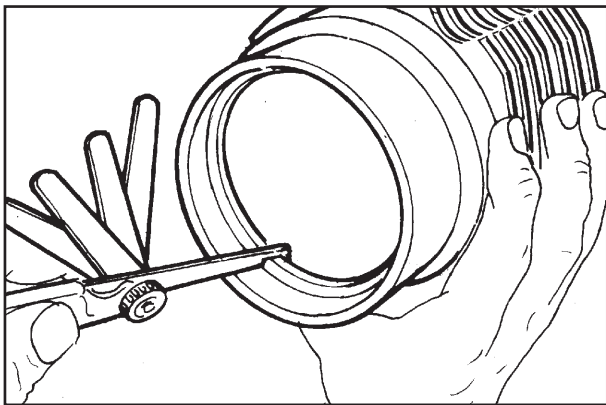

20

Piston rings - Pistons - Piston pins

Check the wear of piston rings by fitting them into the cylinder through the lower end and measuring the end gap (fig.20). The values should be:

Piston ring	Fitting mm	Max. wear mm
Compression	0,30 ÷ 0,50	0,80
Oil scrapper	0,25 ÷ 0,50	0,80

Check that the rings move freely in the grooves and check the ring/groove clearance using a feeler gauge (fig.21).

If the clearance exceeds the values shown in the table, renew the piston and the piston rings.

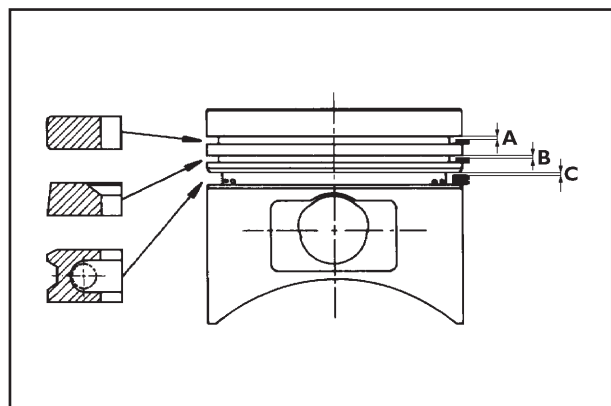

21

Piston ring	Max. wear mm
1st Compression	A = 0,22
2nd Compression	B = 0,18
3rd Oil scrapper	C = 0,16



Piston rings must always be renewed after dismantling the piston.

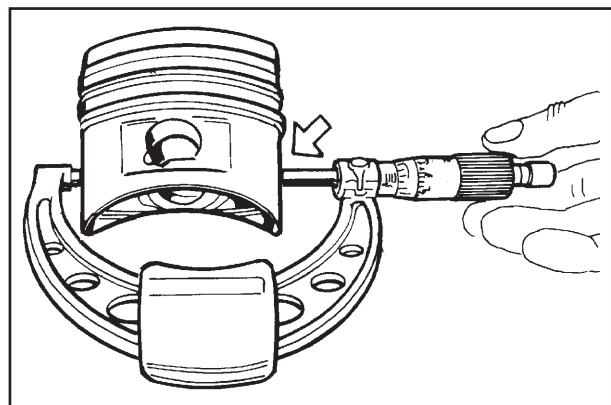

22

Piston diameter check: The diameter of the piston must be measured at approximately 18 mm from the base (fig.22).

Engine	Diameter mm
KD 425-2	84,910 ÷ 84,940

Check the clearance between cylinder and piston, if it is greater than 0.120 mm both cylinder and piston must be replaced. Assembly clearance between piston pin and piston in millimetres:

Fitting mm	Max. wear mm
0,003 ÷ 0,013	0,050

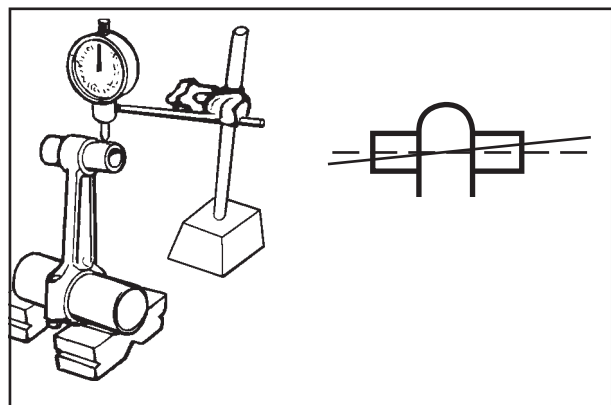

23

Connecting rods

The connection between the connecting rod small end and the wrist pin is without a bushing. Assembly clearance between connecting rod small end and piston pin in millimetres:

Engine	Ø Piston pin mm	Assy. clearance mm	Max wear mm
KD 425-2	21,997 ÷ 22,002	0,023 ÷ 0,038	0,070

Checking parallelism between the two axes of the connecting rod (fig.23):

1. Fit the wrist pin in the hole in the small end of the connecting rod and fit a calibrated pin into the big end (with bush fitted).

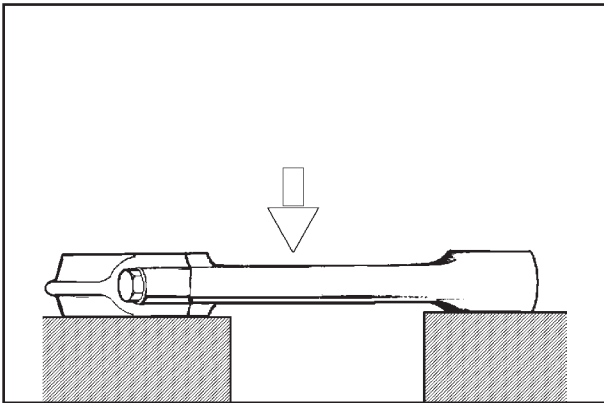

24

2. Position the calibrated pin on two prisms arranged on a check surface.

3. Use a dial gauge to check that the discrepancy between readings at the ends of the calibrated pin is no more than 0.05 mm; should deformation exceed this value (max. 0.10mm) the connecting rod must be straightened.

This operation is performed by placing the connecting rod on a parallel surface and applying slight pressure mid-way along the convex side of the stem (fig.24).

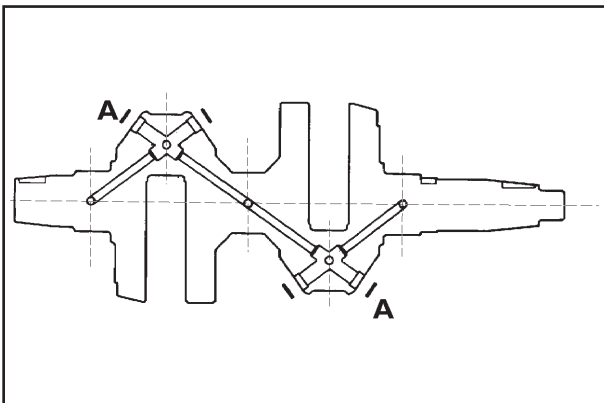

25

Crankshaft

Whenever the engine is dismantled, particularly for the replacement of cylinders and pistons due to wear caused by the aspiration of dust, it is good practice to check the condition of the crankshaft.

1. Remove the plugs "A" from the oil passages (fig.25).

2. Use an appropriately shaped steel punch to clean the inside of the oil passages and the collection traps. If the deposits are particularly resistant, immerse the whole crankshaft in petrol or paraffin before proceeding with the operations.

3. When the oil passages and traps have been thoroughly cleaned, close the openings with new plugs (fig.26).

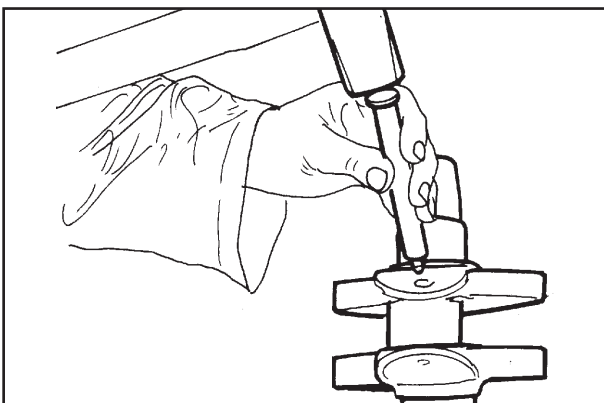

26

Checking crankshaft dimensions

Once the crankshaft has been thoroughly cleaned, use a micrometer to check the wear and ovality of the main journals and crank journals across two sections at right angles to each other (fig.27).

If wear exceeds 0.08 mm (fig.28) grind the crankshaft to the dimensions shown in the table:

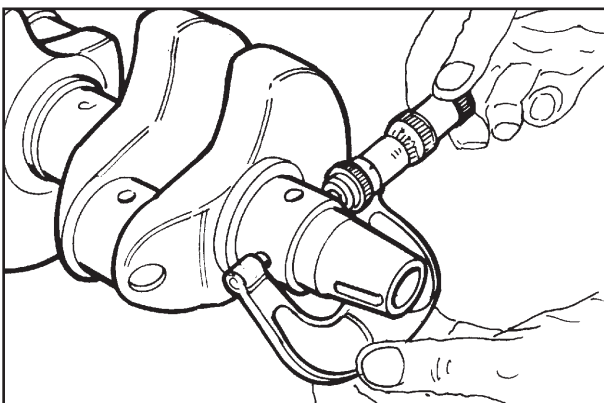

27

Dimensions	STD mm	-0,25 mm	-0,50 mm	-0,75 mm
A - B - D	45,005 \pm	44,755 \pm	44,505 \pm	44,255 \pm
	45,015	44,765	44,515	44,265
C	39,994 \pm	39,744 \pm	39,494 \pm	39,244 \pm
	40,010	39,760	39,510	39,260

Undersize bearing bushes are already available at the necessary sizes without requiring any adjustment by boring.

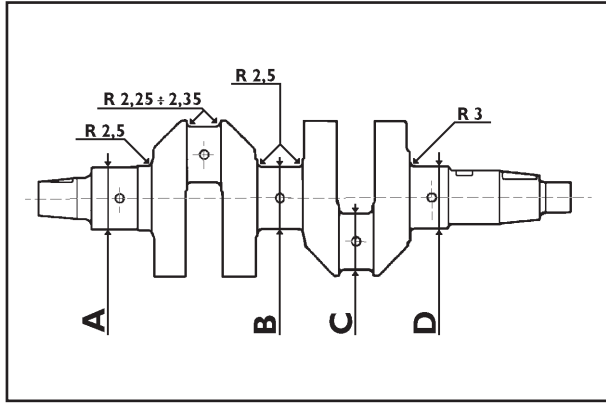

28



During grinding take care not to remove the shim adjustment material from the main journal thrust face to avoid changing the crankshaft end float; also ensure that the grinding wheel radii are as specified in figure 28 so as not to create crack initiation sections on the crankshaft.

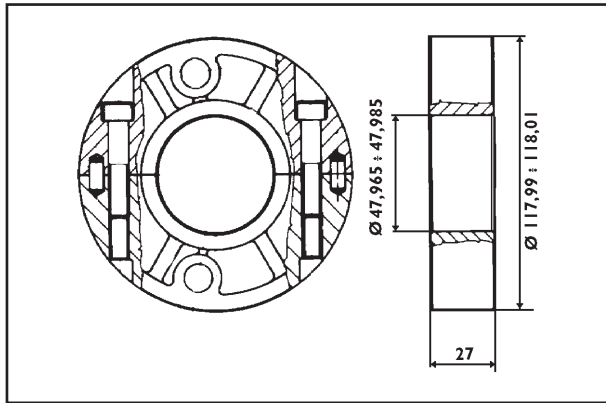

29

Oil seal rings

Check that the rings have not hardened around the internal contact edge and that they show no signs of cracks or wear.

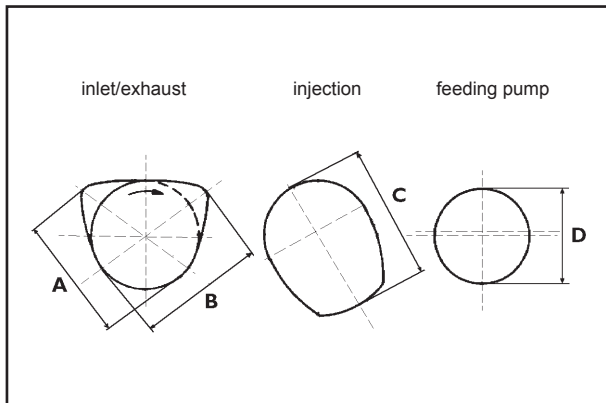

30

Camshaft

Check the cams and bearing journals for scoring and wear. Measure the dimensions and compare them to the values in the table below and shown in figures 30-31.

Camshaft dimensions fig.30.

Cam	Measurement	Dimensions mm
Timing	A B	34,69 ÷ 34,74
Injection	C	34,98 ÷ 35,02
Fuel pump	D	25,50 ÷ 25,70

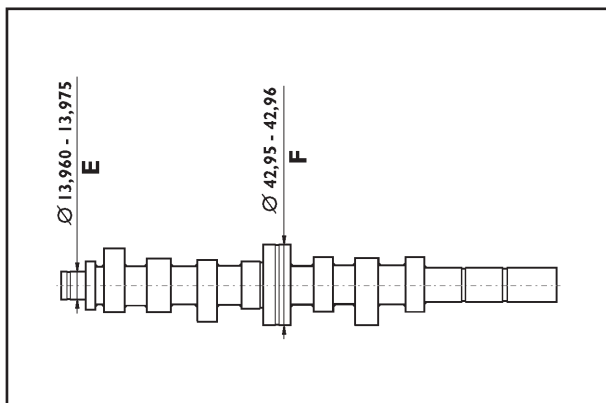

31

Assembly clearance between the journals and their housings should be (fig.31):

Measurement	Clearance mm
E	0,025 ÷ 0,065
F aluminium crankcase	0,07 ÷ 0,105
F cast iron crankcase	0,04 ÷ 0,075



Renew the camshaft if the cams or journals show wear in excess of 0.1mm.

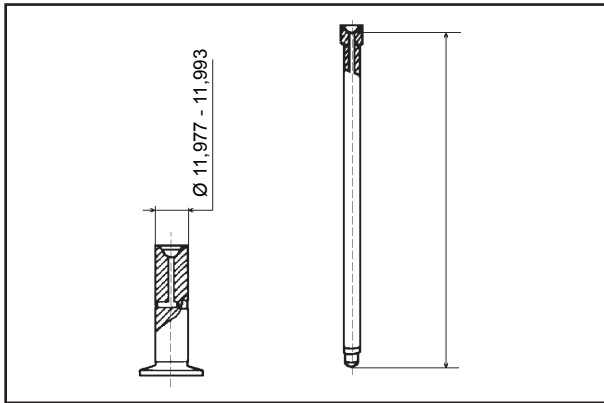

32

Tappets and push rods

Make sure that the tappet surfaces (fig.32) are free from wear and present no signs of scoring or seizure, otherwise, renew.

Assembly clearance between tappets and their housings should be:

Fitting mm	Max. wear mm
0,07 ÷ 0,041	0,10

The push rods must be straight and with the spherical surfaces at either end in good condition (fig.32).

Make sure that the lubrication holes inside the tappets and push rods are free of dirt.

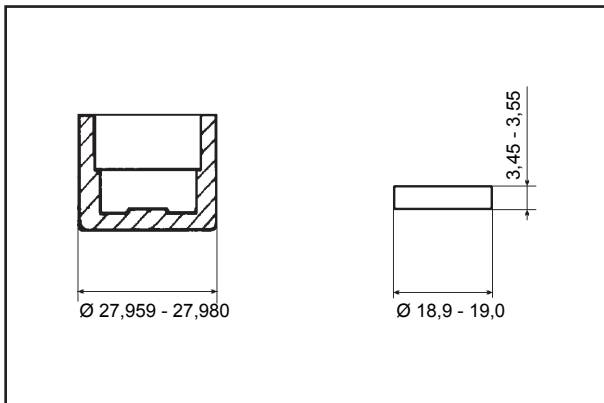

33

Injection pump plug nuts and control rods

Renew the parts if the surface wear is greater than 0.10mm (fig.33).

Assembly clearance between control rods and their housings in the crankcase:

Fitting mm	Max. wear mm
0,02 ÷ 0,059	0,10

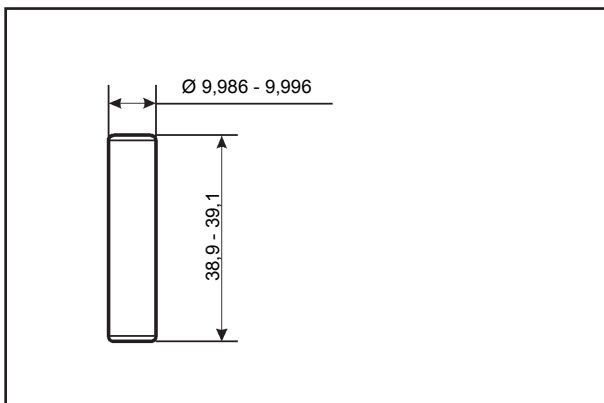

34

Fuel pump push-rod

Check that the surfaces of the fuel pump push-rod, fig. 34, are free of wear, scoring, or signs of seizure, otherwise, renew.

Assembly clearance between fuel pump push-rod and its housing in the crankcase:

Fitting mm	Max. wear mm
0,05 ÷ 0,098	0,120

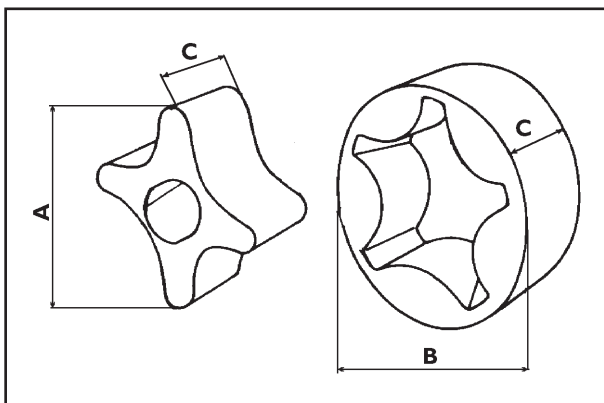

35

Oil pump

Check the rotors and renew them if they have worn lobes or centres. Check the extent of pump wear by taking the measurements indicated in figure 35.

Measurement	Dimensions mm	Max. wear mm
A	29,72 ÷ 29,77	29,65
B	40,551 ÷ 40,576	40,45
C	17,92 ÷ 17,94	17,89

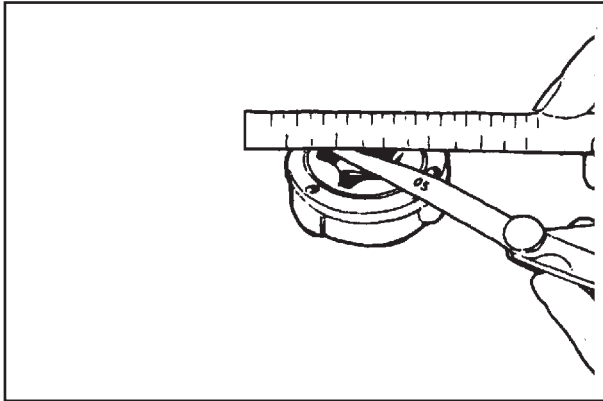

The clearance between the external rotor of the oil pump and the cover facing surface must be:

Fitting mm	Max. wear mm
0,27 ÷ 0,47	0,60

End float of rotors (fig.36):

Fitting mm	Max. wear mm
0,01 ÷ 0,06	0,10

36

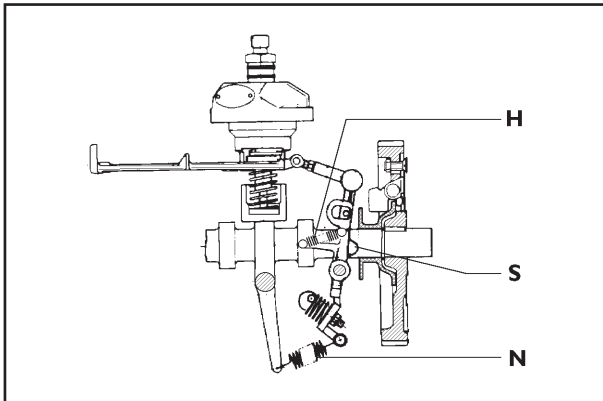

Governor lever and spring

Check that the shoes (**S**, fig.37) are level and that the springs have not lost their elasticity. Renew any excessively worn parts after consulting the spare parts catalogue.

Supplement and governor spring dimensions (fig.37):

Spring	Lenght mm	Lenght under load mm	Load kg	Nr of windings
Governor (N)	32 ÷ 34	53	1,9	14,75
Supplement (H)	25,75 ÷ 26,25	38,7	0,6	25,5

37

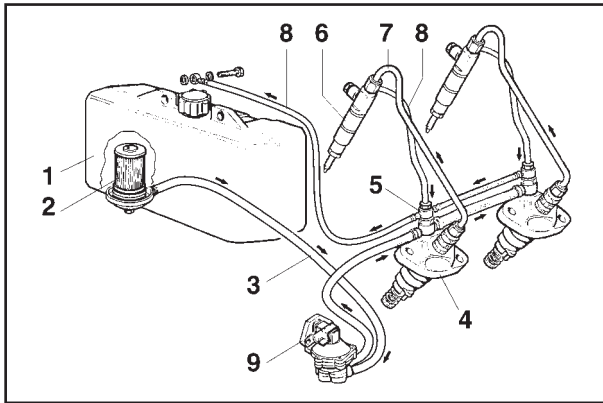

38

Fuel circuit

Fuel feeding can be either gravity type or forced, with a mechanical double diaphragm pump operated a cam located on the camshaft. Fuel is filtered by a filter in the fuel tank or through an external filter cartridge.

The fuel circuit is bled of air automatically.

Components of figure 38:

1. Fuel tank - 2. Fuel filter - 3. Fuel supply lines - 4. Fuel injection pumps - 5. Bleed off connection - 6. Fuel injectors - 7. Injection lines - 8. Fuel return lines - 9. Fuel sully pump.

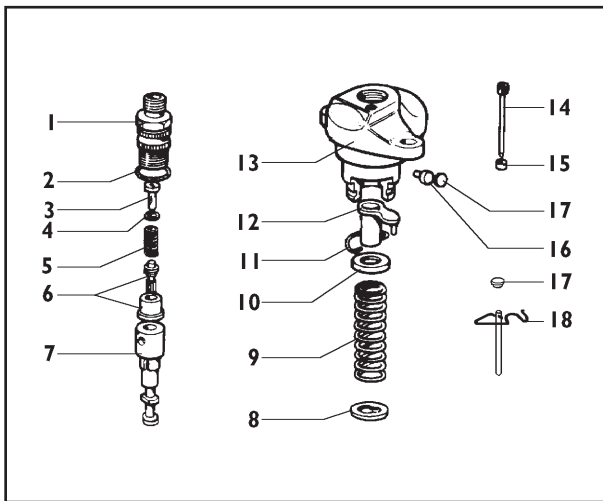

39

Injection pumps

Components of figure 39:

1. Delivery connection - 2. O-ring - 3. Filler - 4. Washer - 5. Valve spring - 6. Delivery valve - 7. Injection plunger - 8. Lower plate - 9. Spring - 10. Top plate - 11. Retaining ring - 12. Adjustment sleeve - 13. Pump body - 14. Sleeve securing pin - 15. Distance ring - 16. Eccentric pin - 17. Cap - 18. Clip for BOSCH pump type PF30.

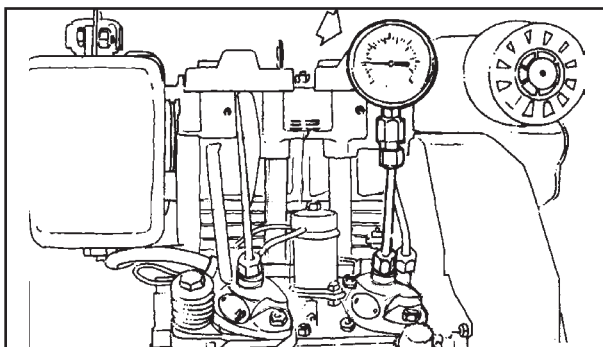

40

Checking injection pumps

Before dismantling the injection pumps check for pressure leak of the pumping unit, plunger and valve, as follows:

1. Connect a pressure gauge with 600 Kg/cm² full scale to the diesel delivery line (fig.40).
2. Set the control sleeve (nr. 12, fig.39) to a mid-point delivery position.
3. Turn the flywheel slowly until the plunger has completed a full compression stroke.
4. Take the pressure gauge reading. If it is below 300 Kg/cm² the complete plunger unit must be changed.

During the test the reading on the gauge will show a progressive pressure increase to a maximum value and then will fall suddenly and stop at a lower pressure. Replace the valve if the fall in pressure exceeds 50 Kg/cm² and continues to fall slowly.

The pressure drop from 200 Kg/cm² to 150 Kg/cm² must occur in a time interval of no less than 7 seconds.

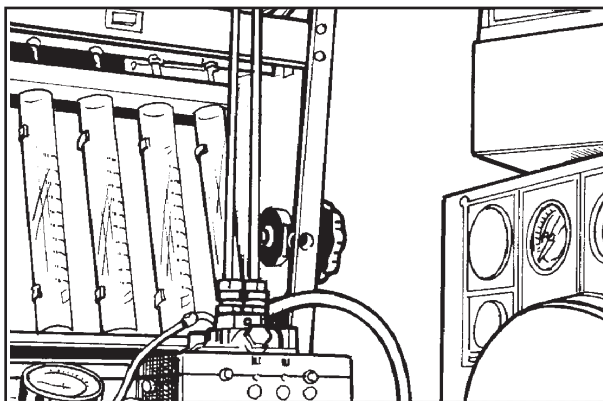

41

Injection pump setting (fig.41)

Set the maximum quantity delivered by the pump by turning the eccentric pin using a screwdriver (nr. 16, fig.39).

With the control sleeve at 10mm from the stop position and the pump running at 1,500 rpm, the quantity of fuel for 1,000 shots must be between:

23 ÷ 25 cc

20 ÷ 22 cc (BOSCH)

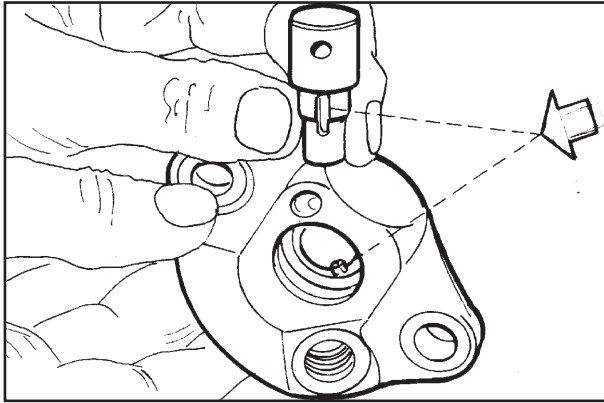

42



The difference between the deliveries of the two pumps when locked must not exceed **0.5 cc**.

Also check:

1. That the distance between the injection cams in the rest position (bottom dead centre) and the pump supporting face is between **52.8 and 54.4 mm** as shown on the data plate;
2. That the stroke of the piston with injection cams in the rest position (bottom dead centre), to the start of delivery is between **2 and 2.1 mm**.

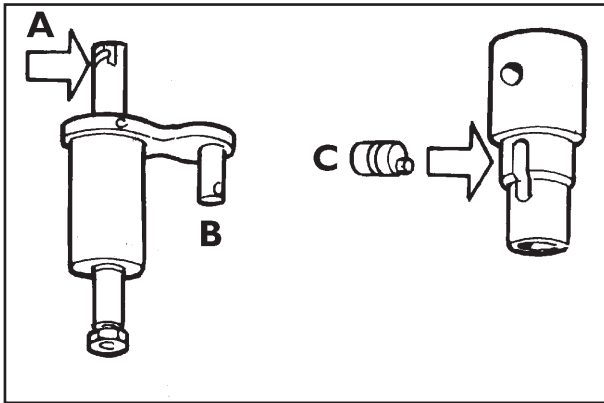

43

Assembly of injection pumps

If it proves necessary to disassemble the injection pumps they must be reassembled following the instructions listed below:

1. Insert barrel into pump casing with the fuel inlet hole aligned with the feeding connection (fig.42). This is the only possible position because of the stud on the pump body. Make sure that the seating face between the barrel and the pump are free of dirt.
2. Insert delivery valve, copper gasket, spring, washer, filler, O-ring, and temporarily tighten the delivery connection.
3. Insert plunger, with helical profile (A, fig.43) on the opposite side of the sleeve pin (B, fig.43), into the internal groove of the control sleeve (make sure the helical profile is turned towards the fuel inlet and eccentric pin (C, fig.43).
4. Complete pump assembly with plunger (a, fig.44), control sleeve (b), upper washer (c), retaining ring (d), spring (f) and secure all with the spring holder washer (g)
5. Tighten delivery valve holder (h, fig.44) to $4.5 \div 5$ kgm torque.
6. Check, by compressing the spring through its various work positions, that the control sleeve (b, fig.44) turns freely and does not stick or encounter resistance throughout its full stroke; any irregular movement will give rise to hunting of engine speeds.
7. Secure the control sleeve using the pin (n, fig.44) screwed into pump housing.

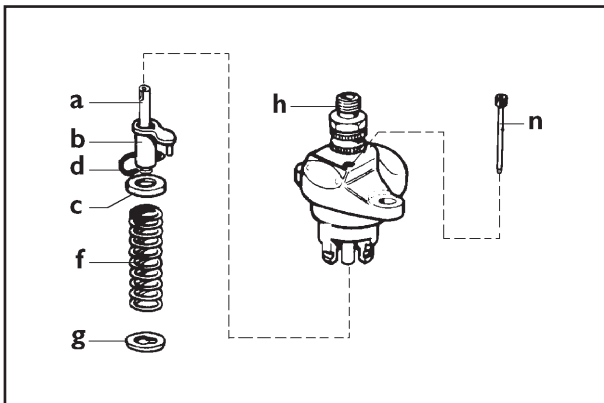

44

Always check the injection pump calibration after the delivery connection (h, fig.44) has been dismantled.

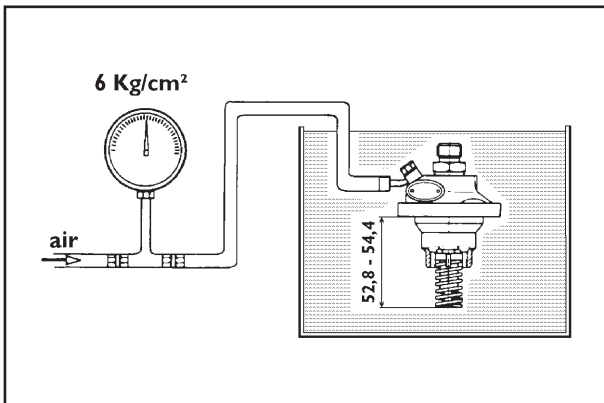

45

Testing air tightness

Feed pressurized air at 6 Kg/cm² into the fuel supply union and completely immerse the pump in oil or diesel fuel for about 20 ÷ 30 seconds (fig.45); check that no air bubbles are released.

N.B.: Tightness can be checked by compressing the springs to 52.8 ÷ 54.4 mm, which corresponds to the bottom dead centre working position of the pump.

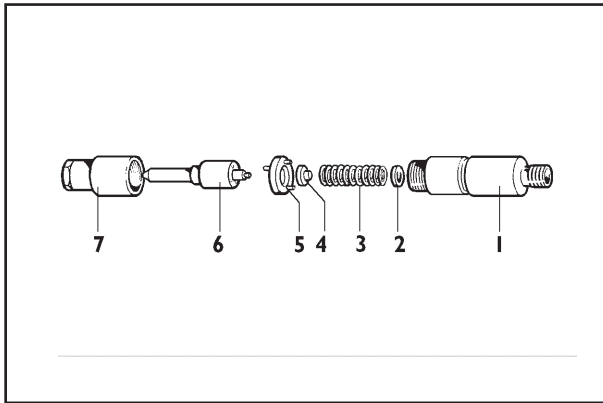

46

Injectors

Details of fig.46:

1.Injector casing - 2.Adjusting shim - 3.Spring - 4.Rod - 5.Distance ring with locating pin - 6.Nozzle - 7.Ring nut

Checking and setting the injectors

1. Clean the nozzle holes with 0.25mm gauge steel wire (fig.47).
2. Place the injector on the test bench (p.n. 00365R0430, fig.48) bypass the pressure gauge and operate the lever rapidly. The nozzle should chatter audibly and spray correctly.
3. Connect the pressure gauge while pressing the lever slowly and steadily until injection occurs. The opening pressure registered on the gauge should be 230 Kg/cm² (200 Kg/cm² on silenced versions). Change the adjusting shims (nr. 2, fig. 46) in order to achieve correct adjustment.
4. Testing for tightness: Operate test bench hand lever until the pressure gauge reads 20 Kg/cm² below the opening pressure of the needle valve. The nozzle can be considered well sealed if there no Diesel fuel accumulates at the nozzle tip after 10 seconds.

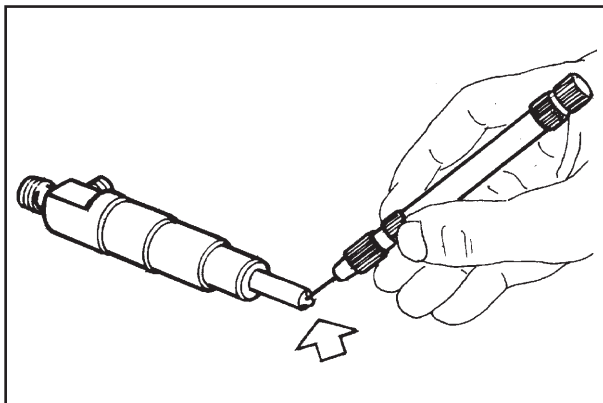

47

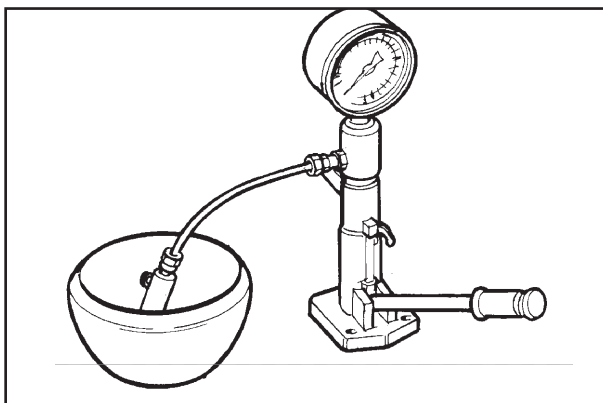

48

Disassembly and re-assembly of injectors

Unscrew the ring nut on the injector nozzle using a ring wrench and a special tool as illustrated in figure 49 serving to release the pressure exerted by the spring on the ring nut.

1. Visual check: make sure that the seat of the needle shows no signs of hammering or excess roughness, that the needle is not worn or damaged, and that the holes are free of carbon deposits.
2. Smoothness test: the needle, previously immersed in diesel and inserted into the nozzle casing, must be pulled out to a third of the length of the guide while holding the nozzle in a vertical position. When the needle is released it should return freely to its seat by the effect of its own weight.

Reassemble the injector following the assembly order shown in figure 46; during reassembly make sure that the locating elements on distance ring 5 (fig.46) are correctly inserted to the corresponding holes. Torque the nozzle securing ring nut to:

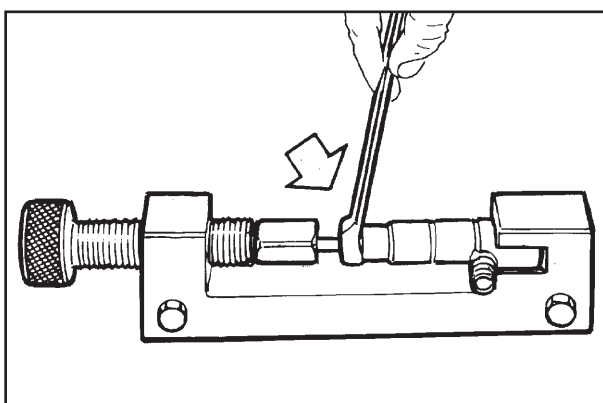

49

kgm 3,5 (Nm 34,3)

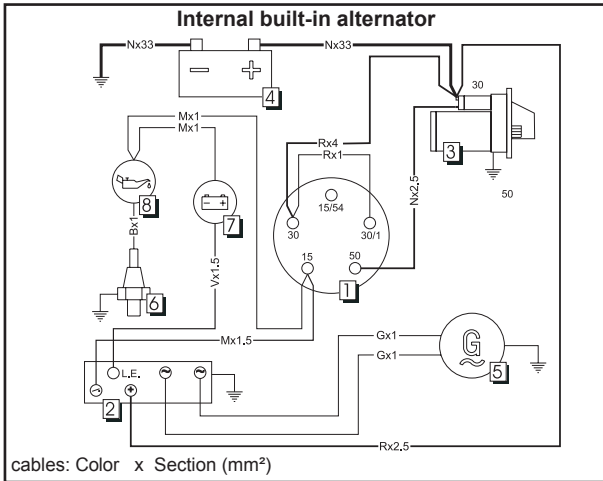

50

Plant specifications

Starter motor: Left rotation, 12V, power from 1.25 to 1.4 kW

Built-in alternator: 280W

Voltage regulator: Electronic with controlled diodes and connection for battery charge indicator light

External alternator: 12V - 400W

Recommended battery: Refer to tables in chapters 4

Flywheel ring gear: Check teeth for wear or damage. Fit crown wheel to flywheel by pre-heating to 200-250°C.

Description (fig. 50-51)	Cables color (fig. 50-51)
1. Ignition key (optional)	M Brown
2. Voltage regulator	N Black
3. Engine starter	A White
4. Battery (not included)	V Green
5. Alternator	R Red
6. Pressure switch	
7. Battery recharge warning light (optional)	
8. Oil pressure warning light (optional)	

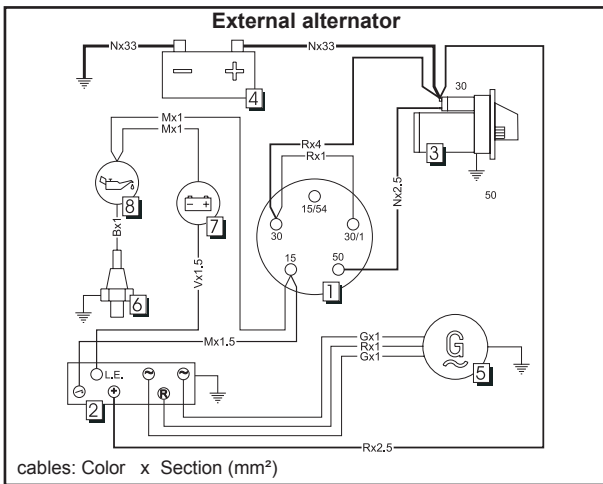

51

Checking electrical equipment

1. Make sure that the connections between the voltage regulator and alternator are correctly made and in good condition.
2. Disconnect the starter motor wire from the battery terminal and connect a dc ammeter (fig.50 and 51).
3. Connect a dc voltmeter to the battery terminals (fig.50 and 51).
4. Turn over the engine a few times without load or connect an 80÷100W lamp load across the battery to restrict voltage to lower than 13V.
5. Accelerate the engine to 3000 rpm. The current shown by the ammeter must be in line with the values indicated in figure 52.
6. Disconnect the load from the battery (if it was previously connected) and keep the engine running at the above indicated speed for a few minutes, the battery voltage should slowly increase until it reaches approximately 14.2V. At the same time the charge current should drop to around 2A in a period of time that depends on whether the battery is fully charged or not.
7. If the charging current is absent or is lower than the value indicated above, proceed by checking the alternator and if necessary, renewing the voltage regulator.

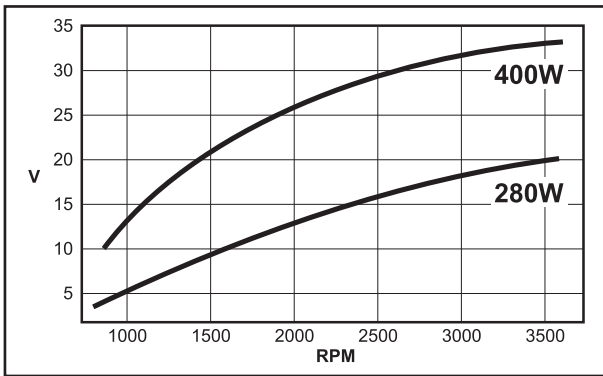

52

Checking the alternator

Check:

1. with motor stopped: the continuity of the windings (fig.53) by connecting an ohmmeter and ensuring that resistance is zero, and the insulation between the windings and ground (fig. 54) by ensuring that the ohmmeter gives a reading of infinite resistance. If these readings are not obtained the stator must be renewed.
2. with motor running: use a multimeter to check the charge current between the two yellow wires. Bring the engine up to 3000 rpm - the multimeter should give a reading of 35V. If the values are more than 10V below this value, the rotor is demagnetized and the alternator must be renewed.

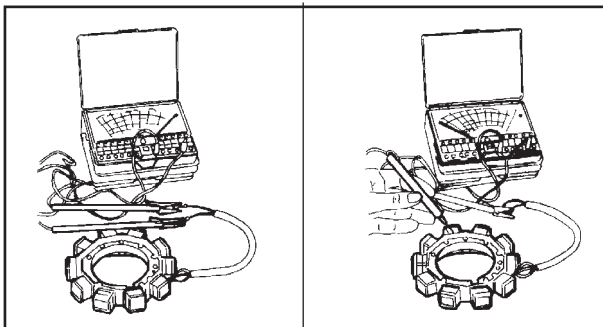

53

54

! Important:

1. The alternator will not deliver current when the yellow wires are disconnected.
2. The alternator will burn out if the yellow wires are connected to ground.
3. The voltage regulator may be damaged if the ground connection or other circuit connections are not made properly.
4. The alternator and the voltage regulator will burn out instantly if the battery connections are inverted.

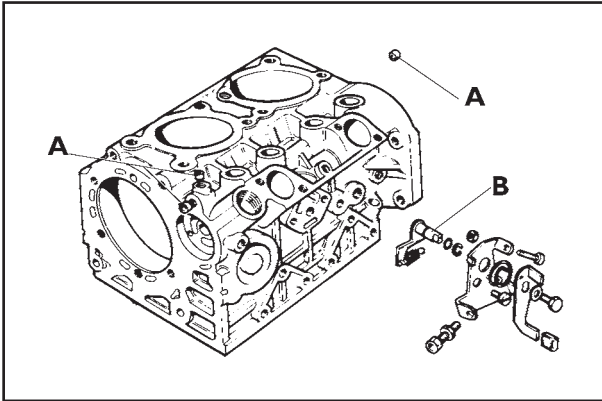

55



Notice: These instructions are valid for engines up-dated prior to the publication of this manual. Any modifications must be checked on the technical circulars.

Before assembling the engine carefully clean all parts and dry them with compressed air. Lubricate moving parts to prevent seizing when starting up. Replace the gaskets with new ones each time the engine is assembled.

Use torque wrenches to ensure that the correct tightening torques are applied.

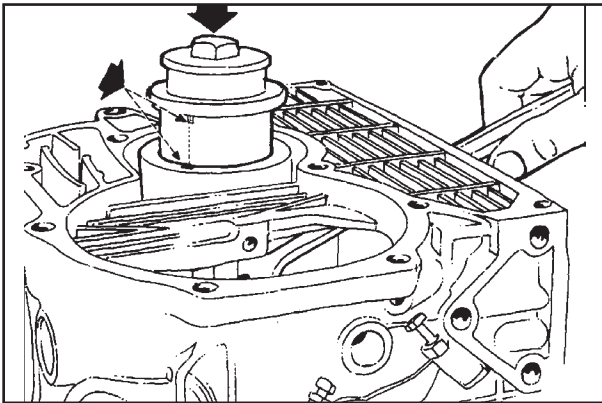

56

Preparing the crankcase

Clean the mating surfaces of sealing compound residues or other foreign material using a copper scraper or fine emery stone. Make sure that the oil passages are open and free of built-up deposits.

1. Fit the plugs (A, fig.55) in their holes.
2. Insert the internal accelerator lever (B, fig.55) into the crankcase with its spring taking care to protect the oil seal O-ring from damage.

Complete the external assembly with plate, spring, lever, etc. as shown in figure 55.

3. Mount the bearing bush (gear train side) using either a standard press or a made-to-measure punch as shown in figure 56. Fit the bush by matching the hole with the passage on the crankcase. Bushes with standard or smaller internal diameters can be ordered as required.
4. Insert the complete oil pressure relief valve (A, fig. 57) into its housing (C, fig.57). Make sure that the valve ball seat is free of dirt that could reduce the effectiveness of the pressure seal. Secure the oil pressure valve with the relative screw (B, fig. 57).
5. Insert the cylinder studs and the centring pins.

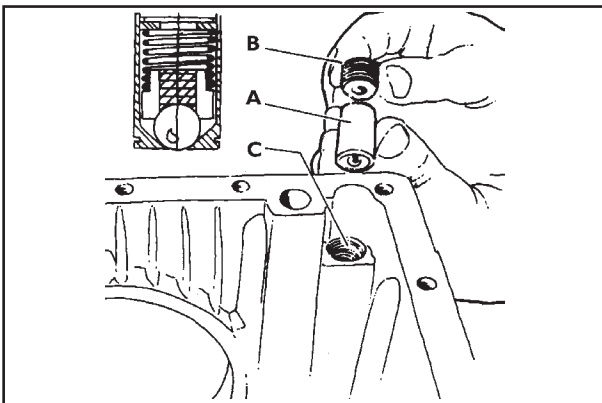

57



A warped oil retainer may allow the introduction of air into the engine thus causing crankcase ventilation problems. Use genuine oil retainers.

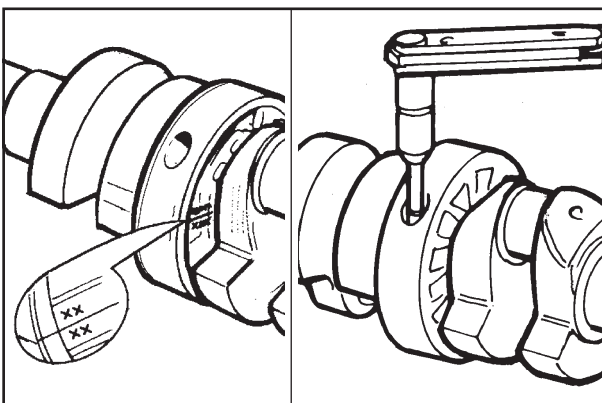

58

59

Central main bearings

Fit the shells into their seats and coat with a thin film of oil.

The reference numbers (fig.58) must be aligned on each half-shell, making sure that the oil passages match the corresponding openings in the crankcase. Torque the bearing assembly bolts (fig. 59) to:

kgm 2,2 (Nm 21,6)

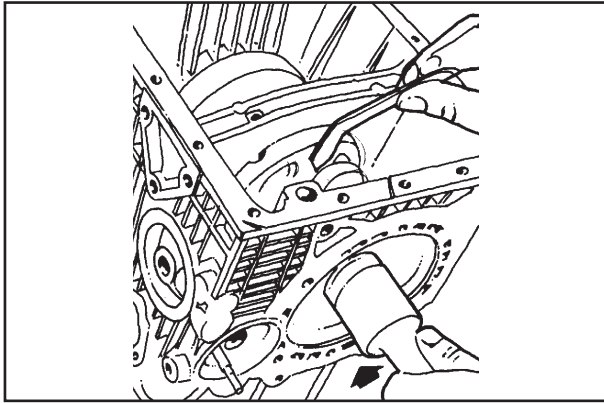

60

Crankshaft

Fit the crankshaft into the crankcase using tool p.n. 00365R0910 as shown in figure 60; make sure that the bearing oil passages are matched to the crankcase oil passages.

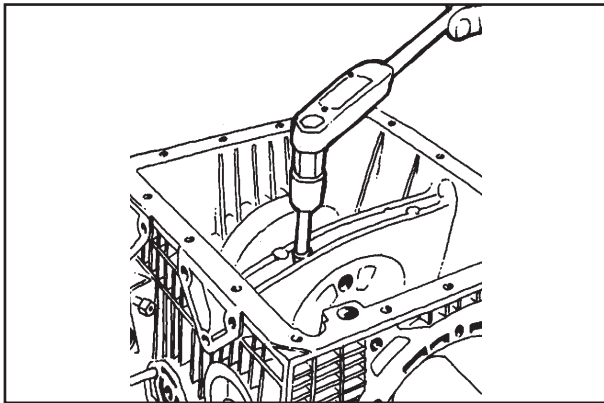

61

Torque the bearing screws (fig. 61) to :

kgm 2,2 (Nm 21,6)

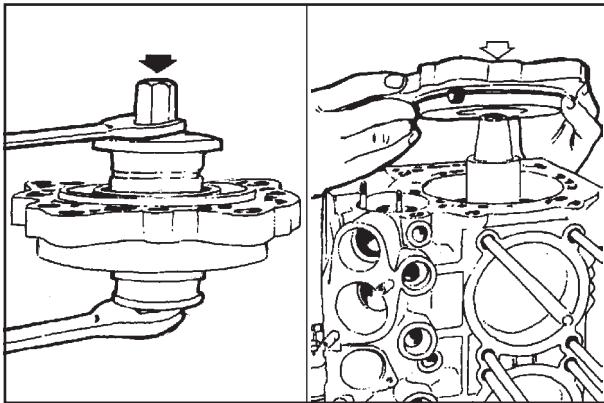

62

63

Main bearings - flywheel side

Fit the bush to the bearing carrier using a special tool of appropriate diameter as shown in figure 62. Insert the bush arranging the groove so that it is facing the internal side of the bearing and positioned vertically.

Fit the oil seal ring to the bearing using a suitable diameter tubular punch.

Fit the bearing into the crankcase after having first interposed an O-ring between the contact surfaces (fig. 63). Torque the screws to:

kgm 2,2 ÷ 2,4 (Nm 21,6 ÷ 23,5)

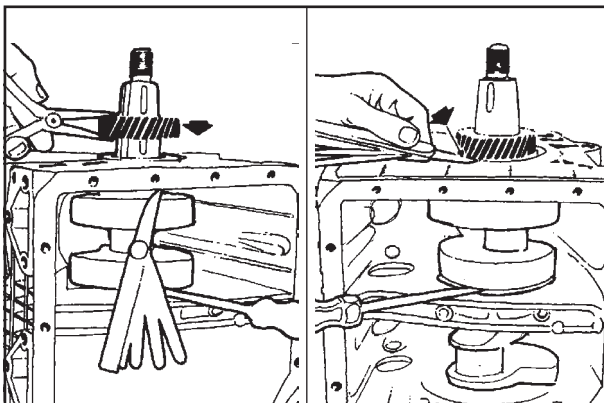

64

65

Crankshaft end float

Install an 0.15 mm feeler gauge between the crankshaft shoulder and the crankcase (flywheel side).

Use a screwdriver to force the crankshaft against its shoulder as shown in figure 64. Pre-heat the timing gear to a temperature of 180 ÷ 200 °C and fit it onto the crankshaft pressing it down until it comes into contact with the crankcase. Wait until the timing gear has cooled down and then withdraw the feeler gauge and the screwdriver and check end float (fig. 65), which must be within the range:

0,10 ÷ 0,20 mm
0,20 ÷ 0,30 mm (cast iron crankcase)

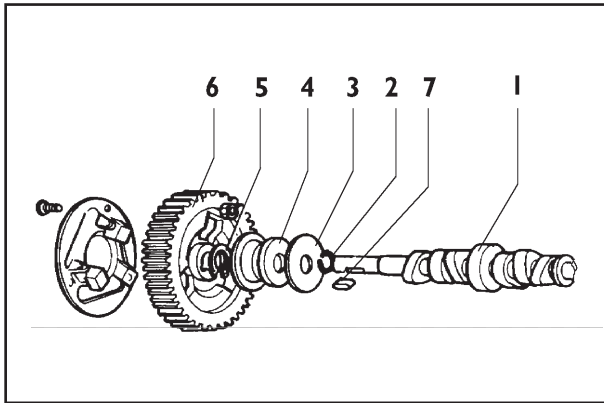

66

Camshaft

Prepare the camshaft assembly (fig.66) as described below:

1. Fit adjustment shim (nr. 3) and governor washer (nr. 4) onto the camshaft.
2. Fit snap ring (nr. 5) and key (nr. 7) into their respective seats.
3. Preheat ($180 \pm 200 \text{ }^\circ\text{C}$) gear (nr. 6) complete with flyweights and mount it to the camshaft, making sure that it is snugly fitted against the retaining ring.
4. Insert the governor driving plate retaining ring (nr. 2).

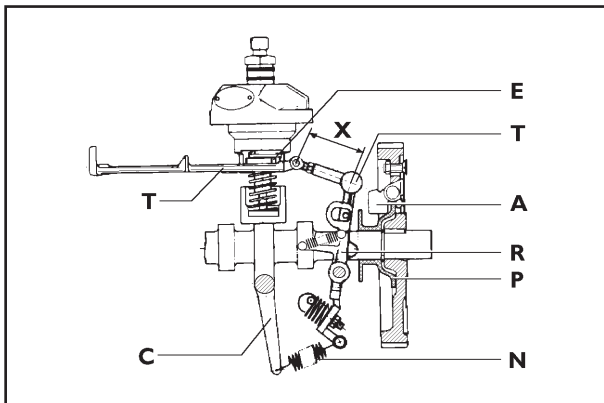

67

The speed governor is of the centrifugal type with flyweights keyed directly onto the end of the camshaft gear (fig.67).

Flyweights (A) impelled outward by centrifugal force, cause a moving plate (P) to shift axially. The plate operates a lever (R) which is connected, through tie rods (T) to the control sleeves (E) of the injection pumps.

Spring (N) placed under tension by speed control lever (C), contrasts the action of the centrifugal force of the governor.

The balance between the two forces keeps the engine speed virtually constant with respect to load variations.

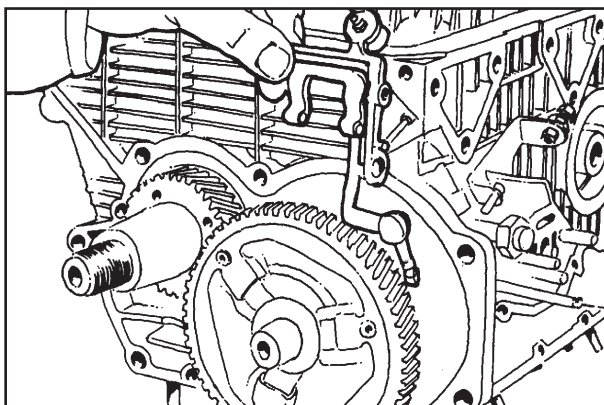

68

Governor tie rod adjustment

The length of the tie rod, measured between the centredistance of holes (X, fig. 67), must be:

mm $36,5 \pm 1$ turn



The accuracy of this setting will serve to eliminate hunting of engine speed, difficulty in starting, and power fall-off.

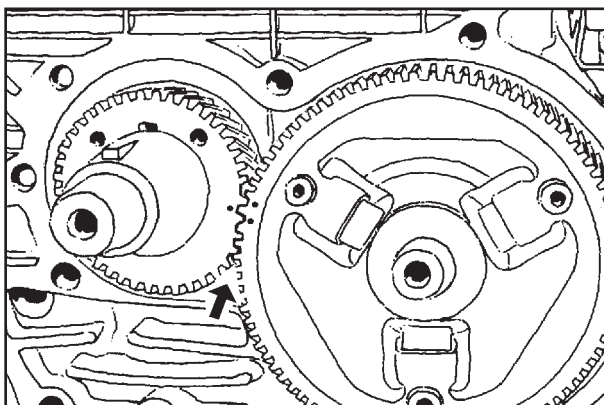

69

Assembly

1. Fit the tappets into their housings in the crankcase
2. Fit the governor lever and tie rod, simultaneously with the camshaft, into the crankcase (fig.68)
3. Insert the governor lever fulcrum pin from the outside of the crankcase and secure it with the relative screw (fig.68). The lever must be free to effect its full stroke without sticking.
4. Insert the spring between the governor lever and the accelerator, making sure that it is correctly installed.
5. Check that the timing marks on the camshaft and crankshaft gears are correctly aligned with respect to each other (fig. 69).

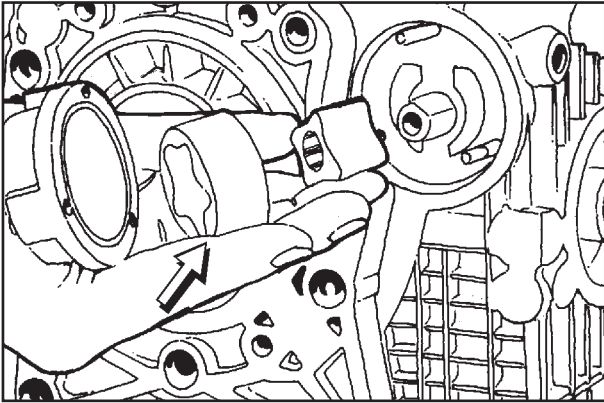

70

Oil pump

See pag. 25 if you wish to check the rotors.

Fit the external oil pump rotor with the bevel toward the inside of the cover (fig.70).

Torque the bolts to:

kgm 0,5 ÷ 0,6 (Nm 4,9 ÷ 5,9)



It is good practice to fill the oil suction pipe in order to aid pump priming when the engine is started up for the first time.

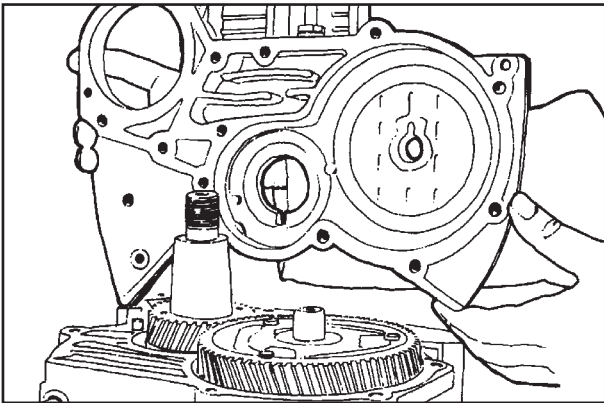

71

Timing cover

Check that the timing markeson the camshaft and crankshaft gears are aligned (fig.69).

Fit the oil seal onto the cover using a normal tubular punch of appropriate diameter. Mount the cover to the crankcase (fig.71) after first inserting a gasket between the mating surfaces; tighten the screws to:

kgm 2,2 ÷ 2,4 (Nm 21,6 ÷ 23,8)

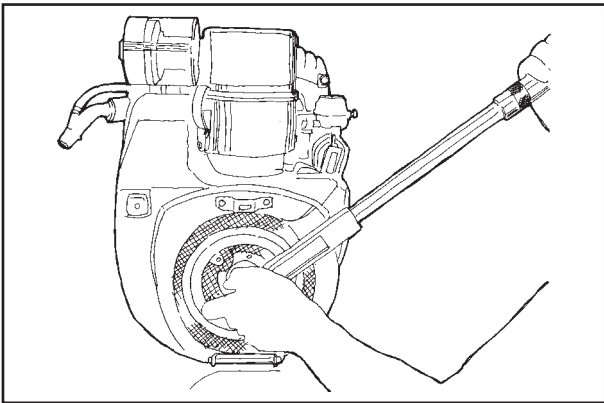

72

Pulley and flywheel

Tighten the pulley and flywheel nut (fig.72) to:

kgm 18 ÷ 22 (Nm 176,5 ÷ 215,7)

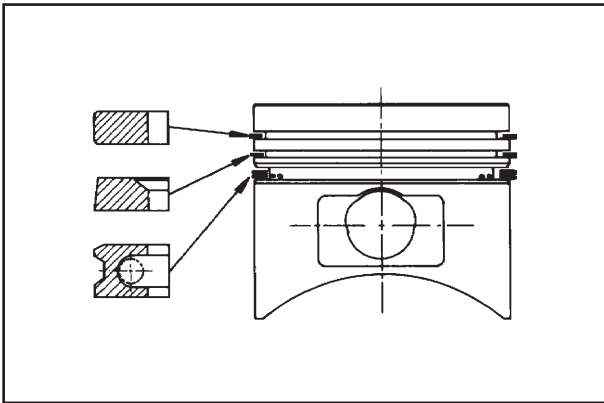

73

Pistons



Lubricate the following parts with oil before mounting: the piston pin, the piston, the cylinder and the big-end bearing

Fit the piston rings onto the pistons (fig.73) in the following order:

1. Chromed compression ring
2. Torsional compression ring (with internal bevel facing upward)
3. Expander oil scraper ring (external bevel facing upward).

Install the piston to the connecting rod, by pushing the wrist pin in, without heading the piston.

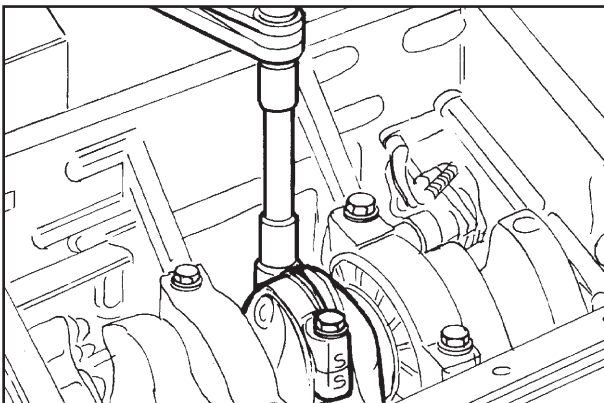

74

Connecting rods

After having fitted the bearings into the big ends mount the connecting rods to the crank journals pins; note that the pistons are marked with an arrow showing the direction of rotation of the engine. The combustion chamber, which is offset with respect to the central axis of the piston, must be turned to face the injector nozzle side. Mount the connecting rod big end cap ensuring that the reference numbers are aligned with those punched on the connecting rod itself (fig.74). Torque the bolts to:

kgm 3,6 ÷ 3,8 (Nm 35,3 ÷ 37,3)

Now fit the oil pan after first inserting the appropriate gasket between the facing surfaces.

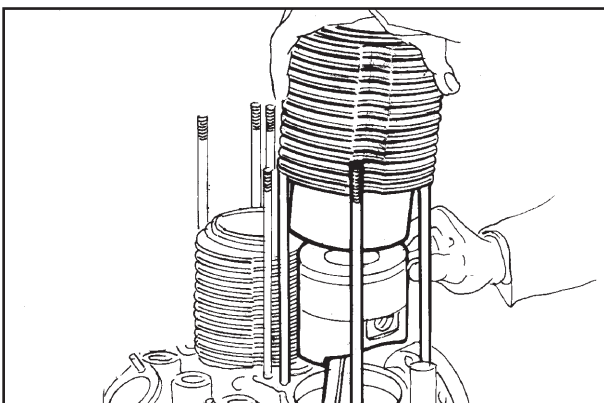

75

Cylinders

Before fitting the cylinders turn the piston rings so that the end gaps are arranged at intervals of 120° with the end gap of the first compression ring aligned with the axis of the wrist pin. The lower face of the cylinders are chamfered to permit the easy insertion of the piston rings. The operation can be simplified, however, using a normal piston ring compressor (p.n. 00365R0770) as shown in figure 75. Mount the cylinders to the crankcase as shown in figure 76 and then bring the pistons up to their respective TDC (top dead centre) positions. The following must now be checked:

1. that the dots punched on the flywheel (TDC) correspond to the reference mark on the flywheel-housing
2. that the pistons protrude over the top surface of the cylinders (fig.76) by a distance of:

0,10 ÷ 0,20 mm

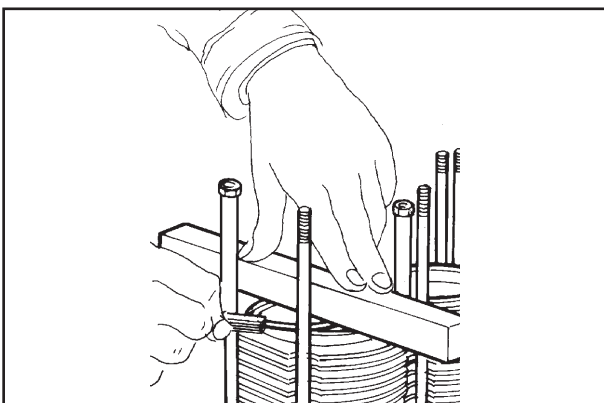

76

This distance is adjusted with special shims that are inserted between the bottom surface of the cylinder and the crankcase 0.1 - 0.2 - 0.3 mm.

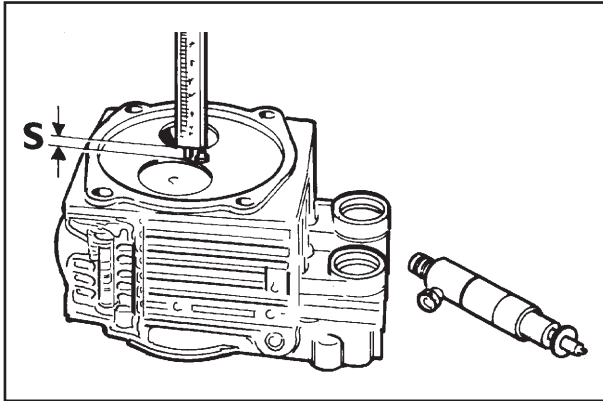

77

Checking injector protrusion

Before mounting the heads to the cylinders fit the injectors into their housings and, after having secured them temporarily, check the protrusion of the nozzles from the head faces (fig.77). Protrusion **S** should be:

1,75 ÷ 2,25 mm

This value is adjusted by inserting copper washers between the injectors and the injector supporting faces on the heads (fig. 77).

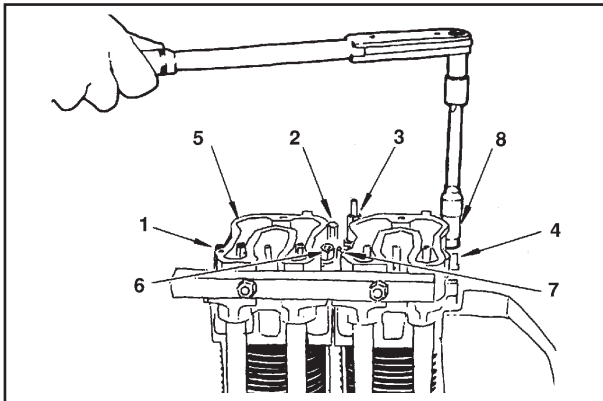

78

Cylinder heads

For checking and overhaul of the cylinder heads refer to page 19. Fit the push rods and oil sealing O-rings on the cover pipes and proceed to install the cylinder heads with the relative gaskets on the facing surfaces.



Make sure that the oil seal rings are correctly seated in the heads to avoid the risk of oil leaks.

Align the heads using a metal bar or the exhaust manifold (fig.78). Following a cross pattern tighten the head nuts (fig.78) in increments of 1 kgm until you reach the value:

4 kgm (Nm 39,2)

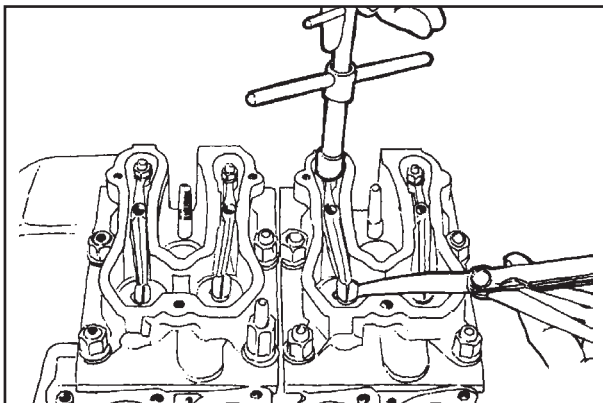

79

Valve clearance

The clearance between valves and rockers with the engine cold (fig.79) is:

0,15 mm
intake/exhaust

This clearance is to be adjusted with the pistons at their respective TDC compression positions.

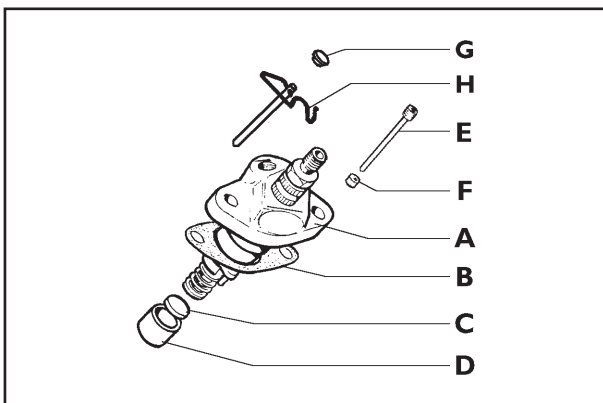

80

Injection pumps

1. Insert the injection pump tappet (D) and spacer (C) into the housings in the crankcase (fig.80).
2. Assemble the injection pumps (A fig. 80) on the crankcase and secure them on the adjustment sleeve by means of the appropriate pins (E or H fig. 80) on PF30 BOSCH pumps. Then, place the advance adjustment shims (B, fig. 80) between the crankcase and the pump.
3. Fix the injection pump connection rod (A, fig.81) to the speed governor lever tie rod (B, fig.81)
4. Secure the injection pumps to the crankcase, taking care to turn the first injection pump around through approximately 3/4 of a turn in a clockwise direction.

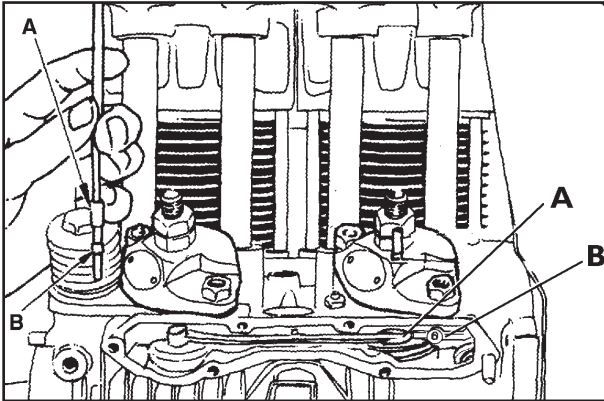

81

5. Release the control sleeves:

- on the traditional pumps by loosening the pins (E, fig.80) and inserting the appropriate distance collars (F, fig.80).
- on the BOSCH type PF30 pumps by removing the pins (H, fig.80) and closing the hole on the pump body using plug G.



Important: injection pumps should be released only after they have been connected to the governor tie rod and secured to the crankcase. If one or both pumps must be changed, in order to guarantee the same fuel delivery for each pump the pump remaining on the crankcase must be locked using the pins (E or H, fig.80). Alternatively the above steps must be performed in their entirety.

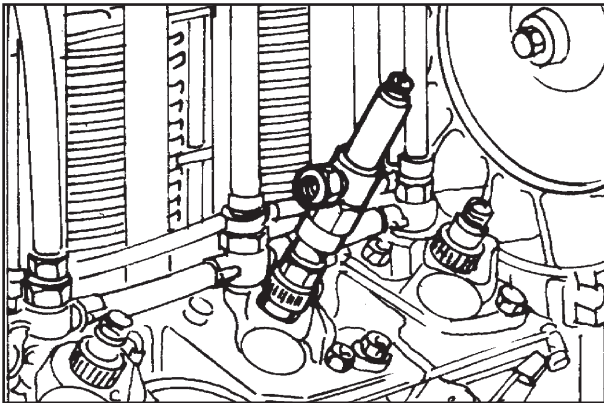

82

Injection check

1. Connect the fuel tank to the injection pumps.
2. Set the speed control lever to Max. (fig.83) and the piston to the start of compression (cylinder nr. 1 on timing gear side).
3. To eliminate the injection delay caused by the milling on the pumping elements, bring the injection pump connection rod (A, fig.81) to a position mid-way between minimum and maximum.
4. Fit the special tool, p.n. 00365R0940, to the delivery valve holder (timing case side) as shown in figure 82.
5. Turn the flywheel slowly until the column of diesel fuel inside the special tool starts to move. This indicates the start of static injection.

For variable advance pumps, the reference mark on the flange bell (fig.85) must match the intermediate point (*) between TDC and "IP" (start of dynamic injection) punched onto the flywheel.

On traditional pumps the static start of injection (*) is the same as the start of dynamic injection (IP).

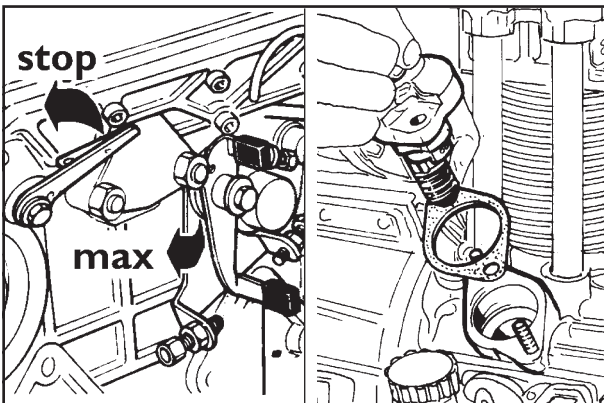

83

84

Should the reference mark (* or IP) fall short of the notch on the flange bell, this indicates that injection is too advanced so that the injection pump must be removed and then reassembled with shims (gaskets) between the pump and the crankcase (fig.84).

Should the reference mark (* or IP) fall after the TDC reference mark, this indicates that injection is too retarded. In this case proceed as above but this time removing shims.

Now repeat the injection timing check for all injection pumps. Note that every 0.1mm shim inserted beneath the pump corresponds to 2.75mm rotation of the flywheel.

Should the flywheel need changing, determine TDC and mark the start of static and dynamic injection as shown in the table:

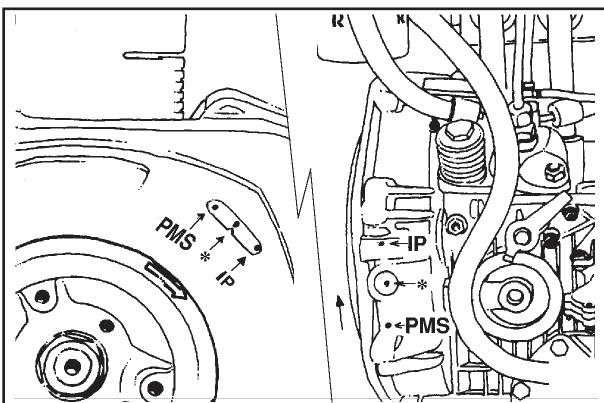

85

Version	I.P.	(*)
standard	22° = 44 mm	17° = 34 mm
whisper quiet	20° = 40 mm	12° = 24 mm

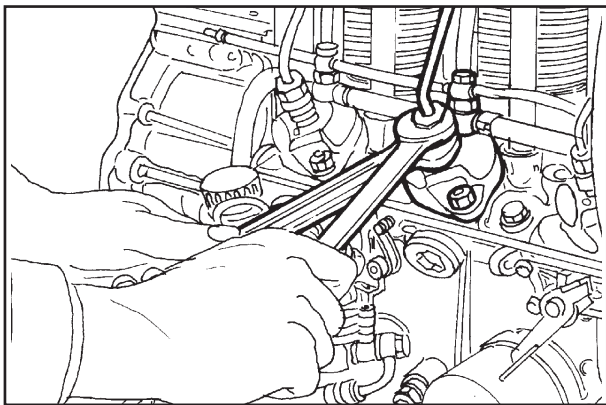

Injectors and injector pipes

Mount injectors to heads placing copper gaskets in between (see pag. 36).
Connect the injectors to the pumps by way of the injection lines.



Important: always use two wrenches to loosen or tighten the unions on the injector pipes (fig.86) thereby ensuring that the position of the delivery valve holder on the pumps is not changed (see pag.27).

86

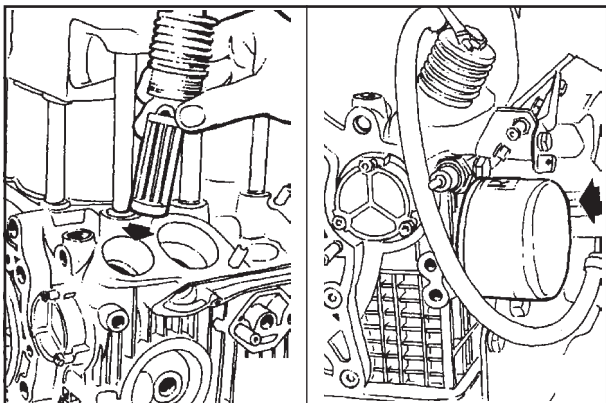

Oil filter

Fit the mesh type oil filter cartridge into the crankcase (fig.87) and check that the rubber seals and the O-ring on the cover are in good condition.

On request or KD 425-2 engines can mount an external filter cartridge that can be screwed onto the crankcase (fig.88). Oil the seal before assembly.

87

88

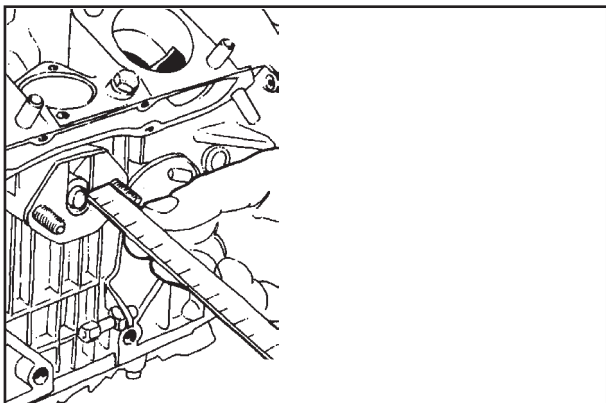

Feed pump

1. Insert the fuel feed pump tappet into its housing and make sure that it moves freely.
2. Fit the 0.2 and 1mm adjustment gaskets.
3. With the fuel pump excenter in rest position the tappet should protrude from the gasket surface (fig. 89) by:

1,3 ÷ 1,7 mm

4. With the fuel feed pump cam in the rest position mount the pump and actuate it manually .

89

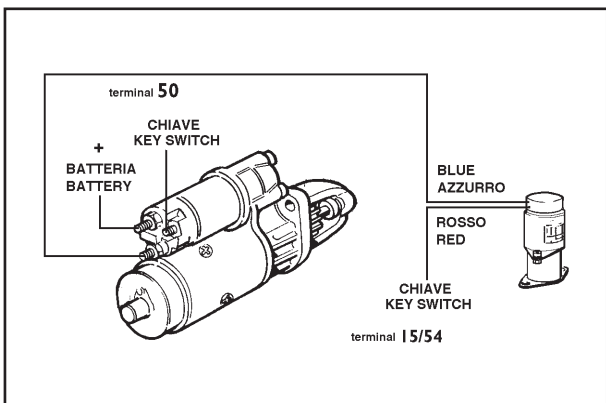

Electric shut off

If the engine is equipped with an electric shut off, insert the electromagnet into the crankcase taking care to position the engine shut-off lever in the STOP position; make sure that the injection pump connection lever moves freely along its entire stroke.

Make the electrical connections as shown in diagram 90.

90

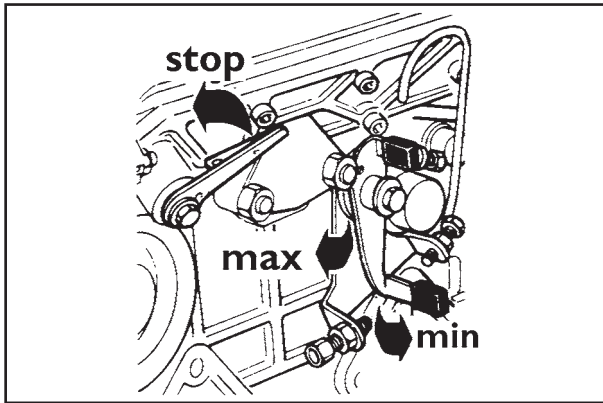

91

Speed adjustment (fig.91)

When the engine is hot set idle speed at 1000 rpm and maximum no-load speed at:

3750 rpm for engines KD 425-2

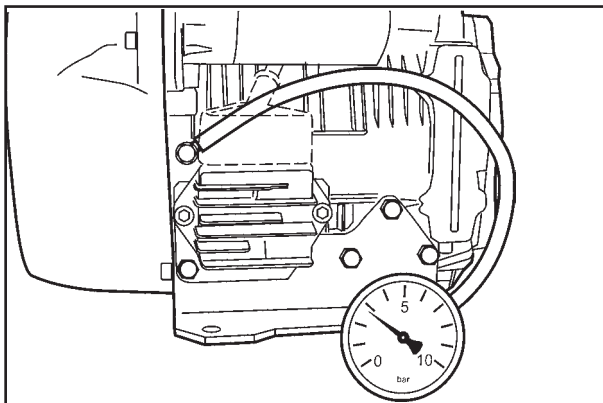

92

Checking oil pressure

1. Remove the bolt from the hole in the crankcase and fit a pressure gauge with 0 to 10 kg/cm² full scale (fig.92)
2. Start the engine, accelerate to 3000 rpm and wait for the oil to reach a temperature of 70 to 80°C.
3. The pressure reading must be between 2.5 and 4 kg/cm².
4. Reduce engine speed to minimum; the pressure should not fall below 1 ÷ 1.5 Kg/cm² with oil temperature of 80°C.

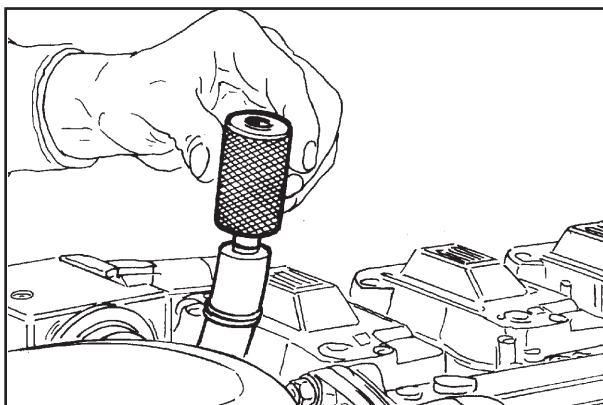

93

Checking for oil leaks

1. Remove the exhaust gas collection pipe from the inlet manifold and close the connection with a plug (fig.93).
2. Start the engine and let it run for a few minutes. The high pressure generated in the crankcase will show up any oil leaks.
3. Reconnect the exhaust gas collection pipe to the inlet manifold.

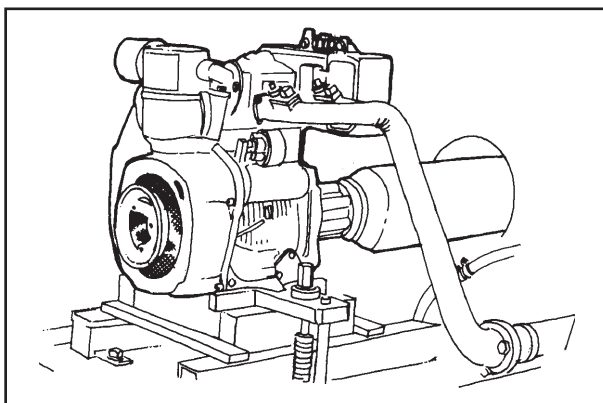

94

Dyno testing of engine

After you have placed the engine on the brake (fig.94) perform the following:

1. Check the oil level (fig.95).
2. Start the engine and let it idle.
3. Check the oil pressure on the pressure gauge (fig.92)
4. Run in engine before testing it at full power.

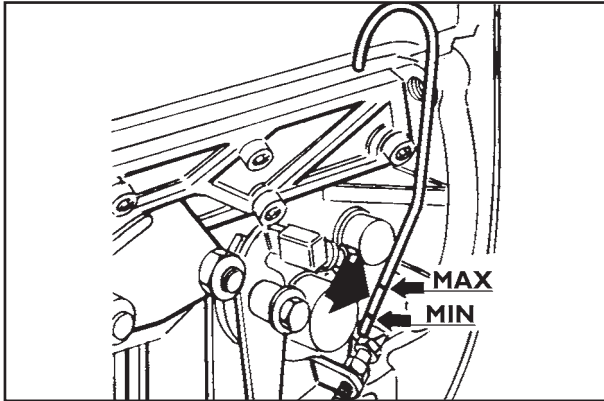

95

Running-in table

Time (min)	RPM	Load
5	2000	0
15	3000/3600	0
30	3000/3600	30%
30	3000/3600	50%
30	3000/3600	70%
5	3000/3600	100%

Engine power curves are reported at page 12.

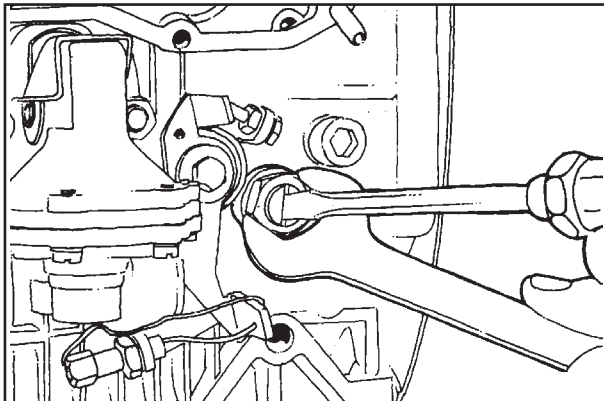

96



In order to check that the setting is correct, without tools, accelerate the engine a few times with no load and check the exhaust fumes.

Delivery of diesel fuel is correctly calibrated when the exhaust gas is slightly coloured by smoke; change the adjustment if necessary by turning the adjustment screw (fig.96).

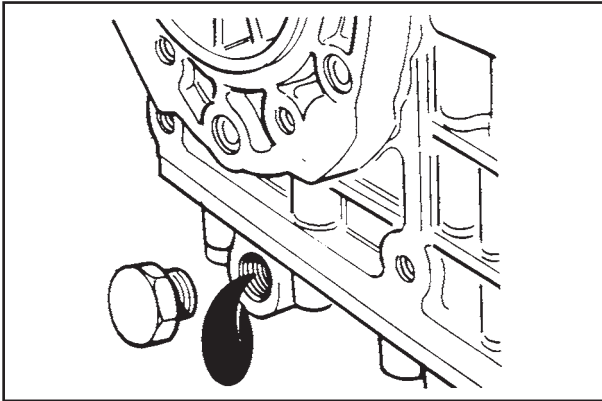

97

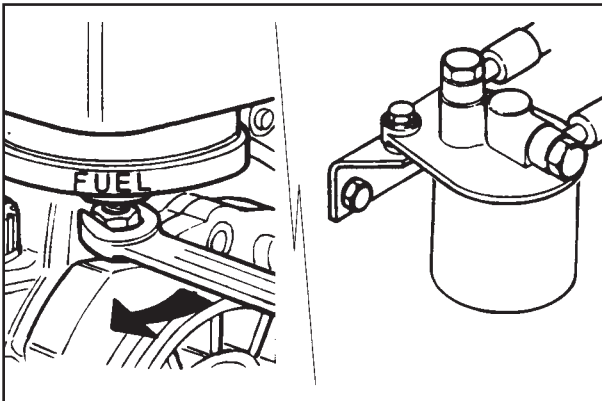

98

Prepare engines as follows for storage over 3 months:

Storage

- Let engine run at idling speed in no-load conditions for 15 minutes.
- Fill crankcase with protection oil MIL-1-644-P9 and let engine run at 3/4 full speed for 5/10 minutes.
- When engine is warm empty oil pan and fill with standard new oil (fig. 97)
- Remove fuel tube and empty the tank
- Remove fuel filter, replace cartridge if dirty and refit (fig. 98).
- Carefully clean cylinder fins, heads and fan.
- Seal all openings with tape.
- Remove injectors, pour a spoonful of oil type SAE 30 into the cylinders and rotate manually to distribute the oil. Refit injectors.
- Spray oil type SAE 10W into exhaust and intake manifolds, rocker arms, valves, tappet etc. Grease all unpainted parts.
- Loosen belt
- Wrap the engine in a plastic film.
- Store in a dry place, if possible not directly on the soil and far from high voltage electric lines.
- For the lubrication and injection system as well as for moving parts use rustproof oil type MIL-L-21260 P10 grade 2, SAE 30 (Ex. ESSO RUST - BAN 623 - AGIP, RUSTIA C. SAE 30) Let the engine run with rustproof oil and drain any excess.
- Coat external unpainted surfaces with antirust type MIL-C-16173D - grade 3 /Ex. ESSO RUST BAN 398 - AGIP, RUSTIA 100/F).



How to prepare the engine for operation

- Clean engine outside
- Remove protections and covers
- Remove antirust with an appropriate solvent or degreaser.
- Remove injector, fill with standard oil, turn crankshaft by a few revolutions, remove oil pan and drain the protective oil.

Couplings	Spiel (mm)	Grezen (mm)
Camshaft and central bearings (aluminium crankcase)	0,070 ÷ 0,105	0,2
Camshaft and central bearings (cast iron crankcase)	0,040 ÷ 0,075	0,2
Camshaft and flywheel side bearing	0,025 ÷ 0,075	0,2
End gap of compression rings	0,30 ÷ 0,50	0,8
End gap of oil scraper rings	0,25 ÷ 0,50	0,8
Connecting rod and wrist pin	0,023 ÷ 0,038	0,07
Rocker arm and pin	0,03 ÷ 0,06	0,15
Fuel pump push rod and housing	0,05 ÷ 0,098	0,12
Injection pump tappets and housing	0,020 ÷ 0,059	0,1
Tappets and housings	0,07 ÷ 0,041	0,1
Oil pump rotor and housing	0,27 ÷ 0,47	0,6
Pistons and wrist pin	0,003 ÷ 0,013	0,05
Inlet valve guide to stem	0,030 ÷ 0,050	0,1
Exhaust valve guide to stem	0,045 ÷ 0,065	0,1

Adjustments	MIN (mm)	MAX (mm)
Crankshaft end float	0,10 ÷ 0,20	0,2
Rocker arm end float	0,05 ÷ 0,130	0,5
Valve clearance	0,15	0,15
Valve depth from cylinder head	0,8 ÷ 1,0	1,3
Injector protrusion	1,75 ÷ 2,25	2,25
Piston protrusion	0,10 ÷ 0,20	0,2

Tightening torques	kgm	(Nm)
Big ends	3,6 ÷ 3,8	(35,3 ÷ 37,3)
Timing cover	2,2 ÷ 2,4	(21,6 ÷ 23,5)
Injector ring nut	3,5	(34,3)
Injectors	2 ÷ 2,3	(19,6 ÷ 22,6)
Injection pump	2 ÷ 2,3	(19,6 ÷ 22,6)
Oil pump	0,5 ÷ 0,6	(4,9 ÷ 5,9)
Injection pump connection	4,5 ÷ 5	(44,1 ÷ 49)
Central bearing halfshells	2,2	(21,6)
Central main bearings	2,2	(21,6)
Main engine bearings - flywheel side	2,2 ÷ 2,4	(21,6 ÷ 23,5)
Cylinder heads	4	(39,2)
Injection pipe	1,5 ÷ 2,5	(14,7 ÷ 24,5)
Flywheel	18 ÷ 22	(176,5 ÷ 215,7)

Standard screw tightening torques						
Denomination	 = 8.8 R ≥ 800 N/mm ²		 = R10 = 10.9 R ≥ 1000 N/mm ²		 = R12 = 12.9 R ≥ 1200 N/mm ²	
	Diameter x pitch mm	Nm	kgm	Nm	kgm	Nm
4 x 0,70	3,6	0,37	5,1	0,52	6	0,62
5 x 0,80	7	0,72	9,9	1,01	11,9	1,22
6 x 1,00	12	1,23	17	1,73	20,4	2,08
7 x 1,00	19,8	2,02	27,8	2,84	33	3,40
8 x 1,25	29,6	3,02	41,6	4,25	50	5,10
9 x 1,25	38	3,88	53,4	5,45	64,2	6,55
10 x 1,50	52,5	5,36	73,8	7,54	88,7	9,05
13 x 1,75	89	9,09	125	12,80	150	15,30
14 x 2,00	135	13,80	190	19,40	228	23,30
16 x 2,00	205	21,00	289	29,50	347	35,40
18 x 2,50	257	26,30	362	37,00	435	44,40
20 x 2,50	358	36,60	504	51,50	605	61,80
22 x 2,50	435	44,40	611	62,40	734	74,90
24 x 3,00	557	56,90	784	80,00	940	96,00

Translated from the original manual in Italian language.

Data reported in this issue can be modified at any time by KOHLER.

KOHLER®

FOR SALES AND SERVICE INFORMATION
IN U.S. AND CANADA, CALL **1-800-544-2444**

KohlerEngines.com

ENGINE DIVISION, KOHLER CO., KOHLER, WISCONSIN 53044

FORM NO.	ED0053029360		
ISSUED	04/07/2012		
REVISED	00	DATE	04/07/2012