

Mira Play

8.5, 9.5 and 10.8 kW Electric Shower

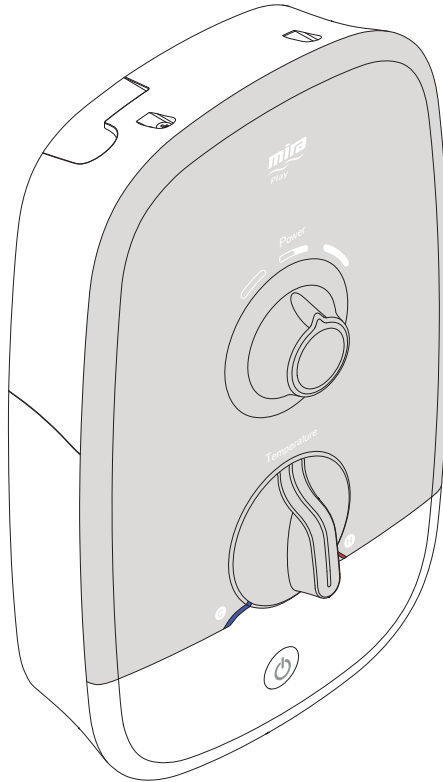

For SPARES,
ADVICE or REPAIRS
please call us free
on 0800 001 4040
(UK only)

Installation and User Guide

These instructions must be left with the user

Showering perfection

mira
SHOWERS

Important Safety Information

WARNING - This shower can deliver scalding temperatures, cause fire, electric shock or other personal injury if not operated, or maintained in accordance with the instructions, warnings and cautions contained in this guide and on the appliance.

Please read the important safety information and the operation section of this guide before using the shower. Failure to follow the instructions provided with this shower will invalidate the guarantee.

TO REDUCE THE RISK OF FIRE, ELECTRIC SHOCK OR INJURY:

1. Children younger than 3 years should not use this shower. Children 3 years to under 8 years should only use this shower under continuous supervision. Children aged 8 years and above and persons with reduced physical, sensory or mental capabilities or lack of experience or knowledge can use the shower if they are given supervision or instruction concerning use of the appliance in a safe way and understand the hazards involved.
2. Children shall not be allowed to play with the shower.
3. **DO NOT** restrict the water flow from the shower outlet, temporarily bending the shower hose or blocking the shower head while in use can cause a hot shot of water to be discharged.
4. Cleaning and user maintenance shall not be made by children without supervision.
5. The outlet must not be connected to any tap or fitting other than those specified.
6. The showerhead must be descaled regularly. Any blockage of the showerhead or hose can cause damage to the shower.
7. **Warning! DO NOT** switch on if there is a possibility that the water in the heater is frozen.
8. The shower must be provided with means for local disconnection from the supply mains having a contact separation in all poles that provide full disconnection under overvoltage category III, the instructions state that means for disconnection must be incorporated in the fixed wiring in accordance with the wiring rules.

9. Installation of the shower must be carried out in accordance with these instructions by qualified, competent personnel. Read all instructions before installing the shower.
10. **DO NOT** switch the shower on if water starts leaking from the shower case. Isolate the electrical supply to the shower immediately.
11. **DO NOT** switch the shower on if the case appears to be damaged or incorrectly fitted. Isolate the electrical supply to the shower immediately.
12. **DO NOT** increase the power setting or adjust the temperature control rapidly while using the shower.
13. **DO NOT** switch the shower off and back on while standing in the water flow.
14. **DO NOT** change the handset model. Fit only shower heads recommended by Mira and do not fit any additional device to restrict the water outlet flow.
15. When adjusting the handset mode, point handset away from body and make sure that the water temperature has stabilised before continuing to shower.
16. Use caution when altering the water temperature, always check the temperature before continuing to shower.
17. Switch the shower off at the electrical isolating switch when not in use. This is recommended with all electrical appliances.
18. Installation of the shower must be carried out in accordance with these instructions by qualified, competent personnel. Read all instructions before installing the shower.
19. Isolate the electrical and water supplies before commencing installation. The electricity must be isolated at the consumer unit and the appropriate circuit fuse removed, if applicable. Mains connections are exposed when the cover is removed.
20. **DO NOT** install the shower in areas with high humidity and temperature (i.e. Steam rooms and saunas).
21. **DO NOT** install the shower where it may be exposed to freezing conditions. Ensure that any pipework that could become frozen is properly insulated.

22. **DO NOT** connect the outlet of the shower to any tap, control valve, trigger operated handset or showerhead other than those specified for use with this shower as the outlet acts as a vent for the tank body. Only Kohler Mira recommended accessories should be used.
23. **DO NOT** perform any unspecified modifications, or drill or cut holes in the product other than instructed by this guide. When servicing only use genuine Kohler Mira replacement parts.
24. **DO NOT** connect this shower to a Waste Water Heat Recovery System as this may cause unstable or scalding temperatures to be delivered from the shower head.
25. Always check the water temperature is safe before entering the shower.
26. The water supplies to this product must be isolated if the product is not to be used for a long period of time. If the product or pipework is at risk of freezing during this period they should also be drained of water.
27. If the shower is dismantled during installation or servicing then, upon completion, an inspection must be made to ensure all electrical connections are tight and that there are no leaks.
28. This appliance is intended to be permanently connected to the water mains and not connected by a hose set.
29. The water inlet of this appliance shall not be connected to a water supply obtained from any other water heating system.
30. **Warning!** This appliance is not to be used to provide a potable water supply.
31. Maximum Static Pressure is 1000 kPa (10 bar).
32. Minimum Dynamic Pressure is 100 kPa (1.0 bar) 10.8 kW.
Minimum Dynamic Pressure is 70kPa (0.7 bar) 8.5 kW and 9.5 kW

Pack Contents

Tick the appropriate boxes to familiarise yourself with the part names and to confirm that the parts are included.

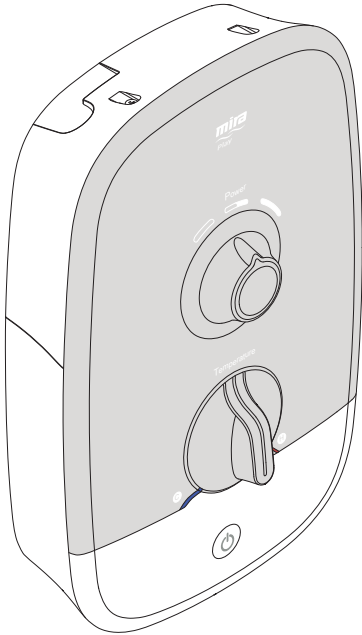

1 x Electric Shower

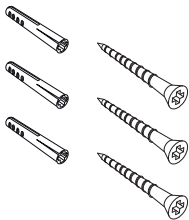

1 x Component Pack

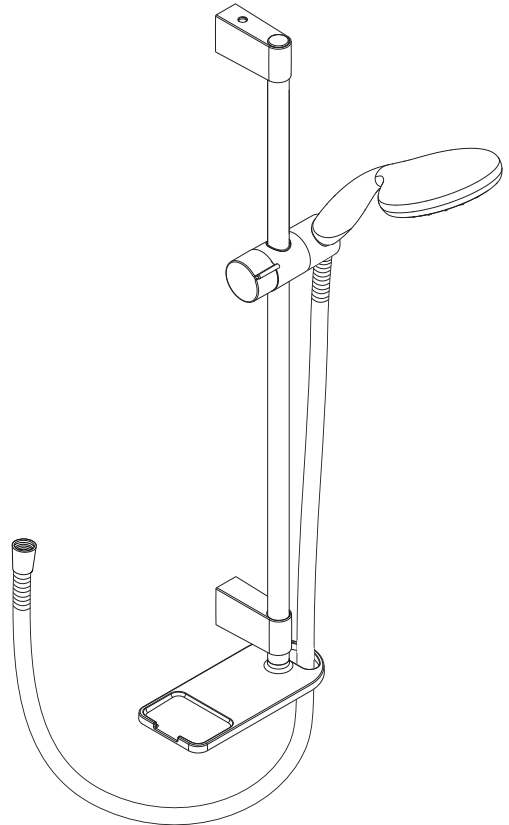

1 x Fittings Pack

Documentation

1 x Installation & User Guide

1 x Guarantee Card

1 x Installation Template

Wiring Diagram

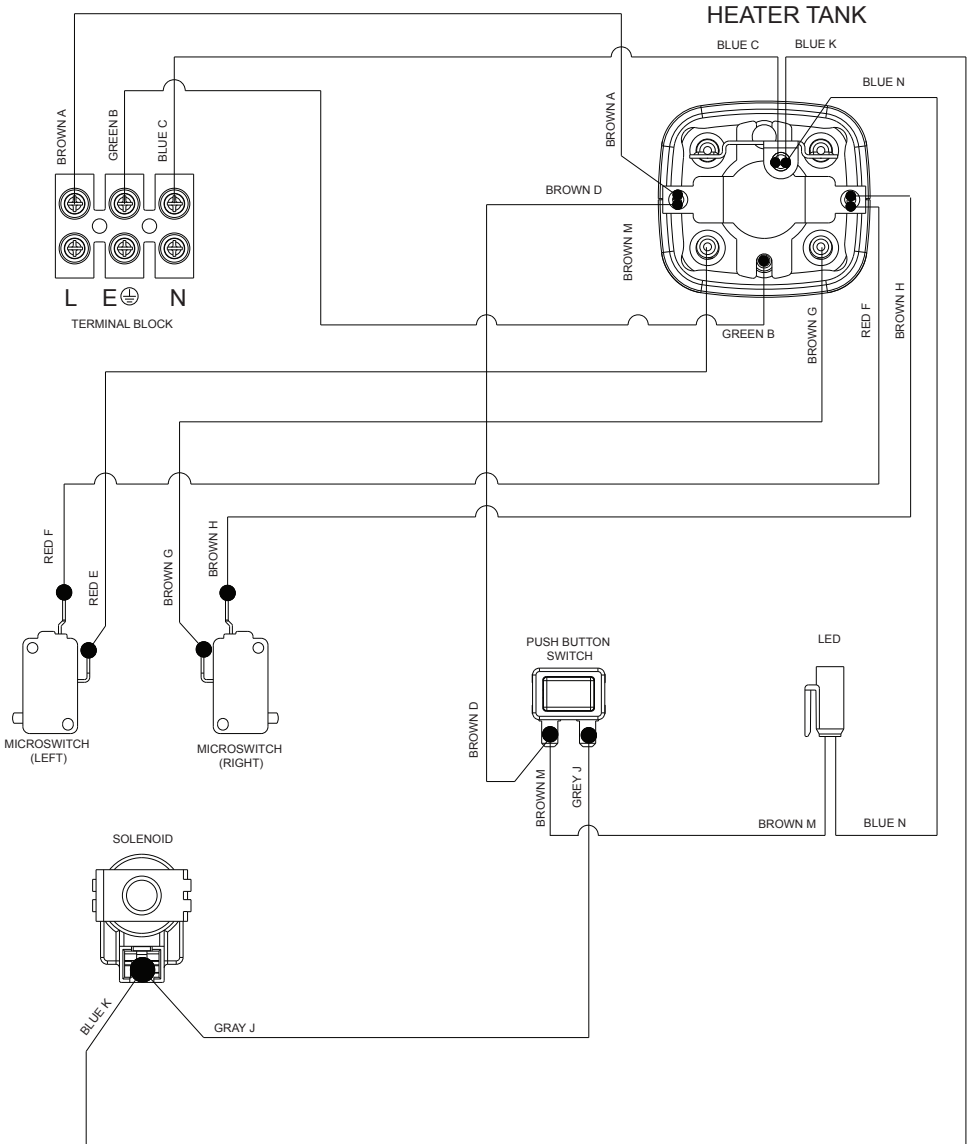

Introduction

Thank you for choosing a Mira shower. To enjoy the full potential of your new shower, please take time to read this guide thoroughly, and keep it handy for future reference. Products manufactured by Kohler Mira Ltd are designed to be safe, provided that they are installed, used and maintained in good working order, in accordance with our instructions and recommendations.

Follow all warnings, cautions and instructions contained in this guide, and on, or inside the shower. This guide is also available in digital format from our website or by contacting customer services.

Products Covered

Product Variant		Model No.	Colour
Mira Play	8.5 kW	J10G	Mira Play 8.5 kW SAT/CHR
	9.5 kW	J10H	Mira Play 9.5 kW SAT/CHR
	10.8 kW	J10J	Mira Play 10.8 kW SAT/CHR

Recommended Usage

Domestic	✓	Light Commercial	✗
Heavy Commercial	✗	Healthcare	✗

Patents and Design Registration

Design Registration:	003617653-0006
Patents:	GB2: 427460; Ireland: 85912

Specifications

Dimensions	
Height	348 mm
Width	224 mm
Depth	101 mm

Plumbing	Variant		
	8.5	9.5	10.8
Min Dynamic Pressure	70 kPa (0.7 bar)		100 kPa (1.0 bar)
Max Dynamic Pressure	500 kPa (5.0 bar)		
Max Static Pressure	1000 kPa (10 bar)		
Min Static Pressure	50 kPa (0.5 bar)		
Max Inlet Temperature	30°C		
Min Inlet Temperature	2°C		
Inlet Connection	15 mm Compression / Pushfit Coupling		
Max Water Hardness	200 ppm CaCO ₃		
Outlet Connection	1/2" BSP Male		

Electrical	Variant		
	8.5	9.5	10.8
Nominal Power at 240 V ac	8.5 kW	9.5 kW	10.8 kW
Nominal Power at 230 V ac	7.8 kW	8.7 kW	9.9 kW
Recommended MCB Rating	40 A	40 A	45 A
Max Supply Cable Size	16 mm ²		
Recommended RCD Rating	30 mA tripping current		
Recommended Isolator Switch	45 A double-pole with 3 mm contact separation		
Appliance Sealing Rating	IP X4 - Suitable for installation in Zone 1		
Max Ambient Temperature	30°C		
Min Ambient Temperature	2°C		

Guarantee

For **domestic installations**, Mira Showers guarantee the Mira product against any defect in materials or workmanship for a period of **two years** from the date of purchase (shower fittings for one year).

For **non-domestic installations**, Mira Showers guarantee the Mira product against any defect in materials or workmanship for a period of **one year** from the date of purchase. For Terms and Conditions refer to the back cover of this guide.

European Conformity Information

This range of electric showers complies with the following European directives:

- 2014/35/EU - Low Voltage Directive (LVD),
- 2014/30/EU - Electromagnetic Compatibility Directive (EMC),
- 2011/65/EU - Restriction of Hazardous Substances Directive (RoHS)

This range of electric showers are high power appliances and are subject to conditional connection. If the main electrical supply fuse is rated less than 80 Amps, the local electricity supply company must be contacted to confirm if the electrical supply is adequate.

This range of showers complies with the requirements of the UK's water regulations.

Disposal and Recycling

End of Product Life

Electrical and electronic devices contain a range of materials that can be separated for recycling and used in new products.



This product should not be disposed of with your general household waste. When this product has reached the end of its serviceable life, please remove any batteries and take it to a recognised WEEE (Waste Electrical and Electronic Equipment) collection facility such as your local civic amenity site for recycling.

Your local authority or retailer will be able to advise you of your nearest recycling facility.

Installation Requirements

Plumbing

1. The plumbing installation must comply with all national or local water regulations and all relevant building regulations, or any particular regulation or practice specified by the local water supply company.
2. **DO NOT** use sealing compounds on any pipe fitting or joints.
3. **DO NOT** install the product in a position in which service access is limited.
4. Decide on a suitable position for the shower (minimum distance of 200 mm from the ceiling to allow for cover fit and removal).
5. The shower is suitable for installation within the shower area and is fitted with a pressure relief valve. It must be positioned over a water catchment area with the controls at a convenient height for the user.
6. The shower must be fitted to a waterproof flat and even wall surface.
7. **DO NOT** fit the shower to the wall and tile up to the case.
8. **DO NOT** seal the gap between the shower and the wall surface.
9. The showerhead should be positioned so that it discharges down the centre line of the bath or across the opening of a shower cubicle.
10. The showerhead must be directed away from the shower unit, during normal use the showerhead must not spray directly on to the shower unit.
11. **DO NOT** apply excessive force to plumbing connections; always provide mechanical support when making plumbing connections. Any soldered joints should be made before connecting the shower.
12. This shower is not designed to be plumbed directly from the rear. For rear-entry supply, add an elbow to the supply pipe and connect as a rising or a falling supply.
13. If pipework and/or electrical cables enter the shower from the rear through a hole in the wall provision must be made to prevent water ingress back into the wall structure.
14. This shower is intended to be permanently connected to the mains water supply, only use the inlet connection supplied with the shower.
DO NOT use any other type of fitting.
15. A full bore/non restrictive servicing valve must be fitted in a readily accessible position adjacent to the shower to facilitate maintenance of the shower. **DO NOT** use a valve with a loose washer plate (jumper) as this can lead to a build up of static pressure.
16. A water treatment device should be installed where the water hardness may exceed 200 ppm. Malfunctions caused by excessive limescale formation are not covered by this shower's guarantee (see back page for details).
17. The installation must not cause the hose to be sharply kinked during normal use.
18. **DO NOT** perform the electrical installation until the plumbing has been completed and checked for leaks.

19. The position of the shower and shower fittings must provide a minimum gap of 25 mm between the showerhead and the spill over level of any bath, shower tray or basin and a minimum gap of 30 mm between the showerhead and the spill over level of any toilet, bidet or other appliance with a Fluid Category 5 backflow risk.

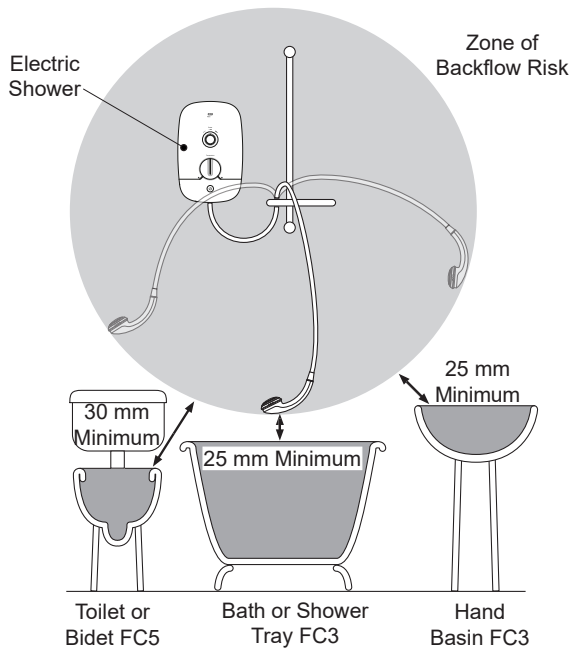

Hose retaining ring fitted and shower fittings fixed at a suitable height preventing dirty water backflow

Note: There will be occasions when the hose retaining ring will not provide a suitable solution for Fluid Category 3 installations, in these instances an outlet double check valve must be fitted, this will increase the required supply pressure typically by 10kPa (0.1 bar). Double check valves fitted in the inlet supply to the appliance cause a pressure build up, which affect the maximum static inlet pressure for the appliance and must not be fitted. For Fluid category 5 double check valves are not suitable.

Electrical

1. The electrical installation must comply with BS 7671 (commonly referred to as the IEE Wiring Regulations) and all relevant building regulations, or any particular regulation or practice specified by the local electricity supply company.
2. Ensure that all circuit protection devices, switches and cabling is adequate for the rated current of the shower and that the rating of the electricity supply company fuse and the consumer unit are adequate for the additional demand.
3. The shower **must** be earthed. Ensure any supplementary bonding complies with the relevant regulations.
4. This shower is intended to be permanently connected to the fixed electrical wiring of the mains system. A separate supply **must** be provided from the consumer unit to the shower.
5. **DO NOT** supply any other electrical equipment including extractor fans or pumps via this product.
6. This shower must be provided with means for local disconnection that is incorporated into the fixed wiring in accordance with the relevant local wiring regulations. This **must** be a double pole switch, which has at least 3 mm contact separation in each pole. The switch can be a ceiling mounted pull-cord type within the shower room or a wall mounted switch fitted in the applicable zone area.
7. For new installations a 30mA Residual Current Device (RCD) **must** be incorporated into the electrical supply to this shower in accordance with current wiring regulations. When replacing an existing electric shower we recommend that a 30mA RCD be incorporated in accordance with current wiring regulations if not already provided
8. **DO NOT** apply excessive force to the terminal block.
9. All electrical connections should be checked for tightness to prevent overheating before switching on the electrical supply.
10. **DO NOT** switch on the electrical supply until the plumbing has been completed and checked for leaks.

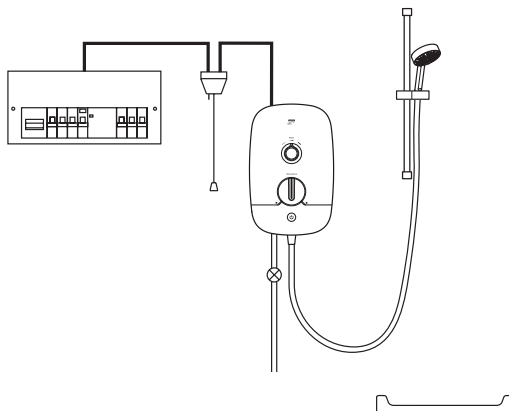

Plumbing and Electrical Schematic

Installation



Warning, isolate the electrical and water supplies before installing the shower!

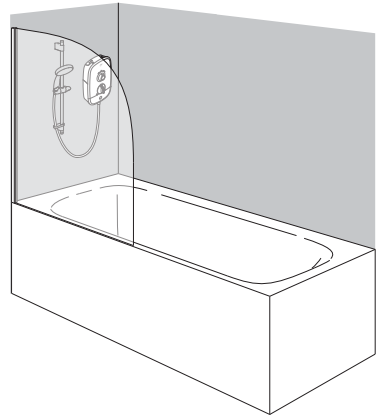
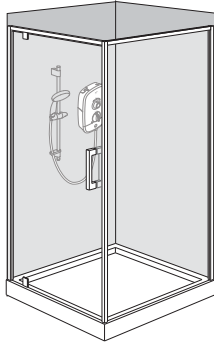

Decide on a suitable position for the shower unit and fittings leaving adequate space for maintenance. A suitable position for the shower will have a minimum clear distance of 200 mm from the ceiling. See ***“Installation Requirements - Plumbing”*** for further details.

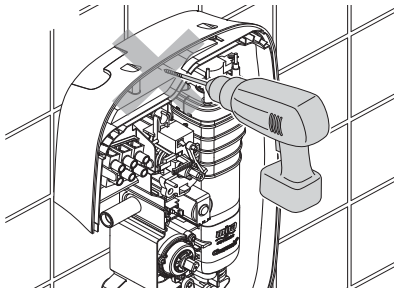
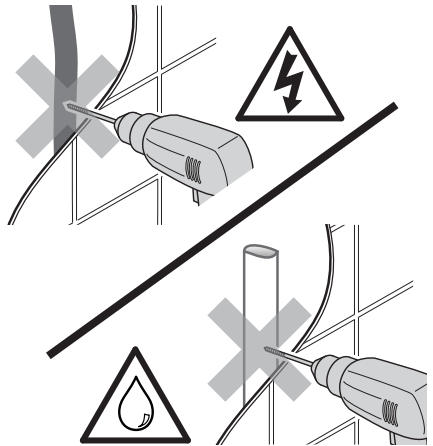
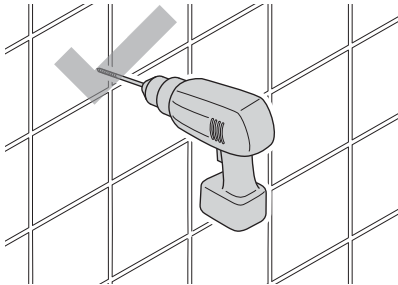

DO NOT drill through the shower unit into the wall.

DO NOT drill into buried cables or pipes.

Make sure that you use the installation template (supplied).

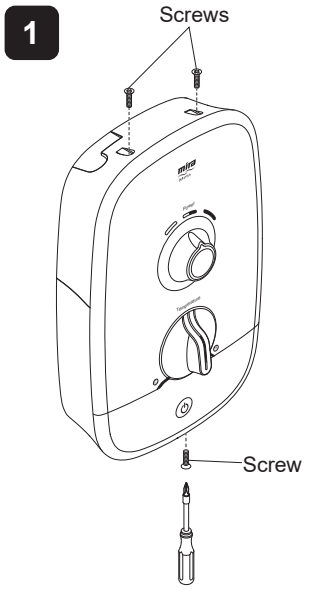

Remove the cover screws.

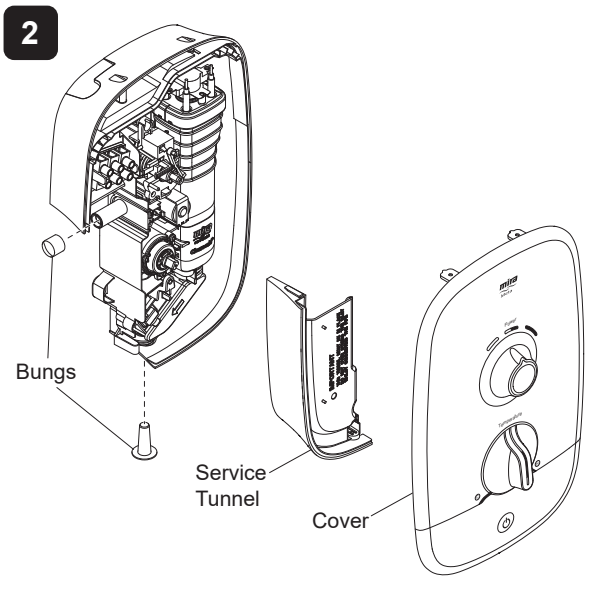

Remove the cover, the service tunnel and the bungs.

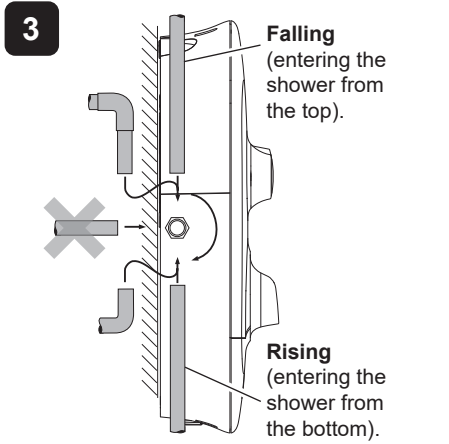

Determine the direction and route of the incoming water supply as shown.
Note! - **DO NOT** use an incoming supply entering the shower directly from the back. Add an elbow to the supply pipe and connect it as a rising or falling supply.

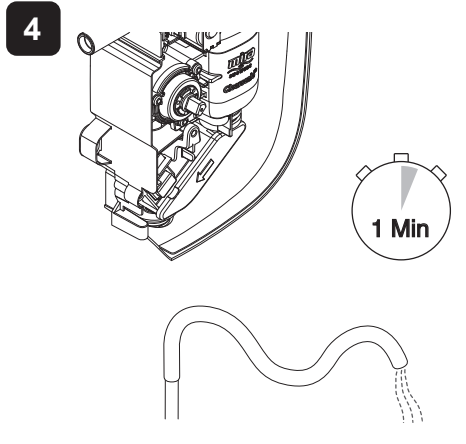

DO NOT flush through the product by removing the inlet filter. Debris may damage the product and invalidate the guarantee.
 Flush for approximately 1 minute through pipework prior to connection.

5

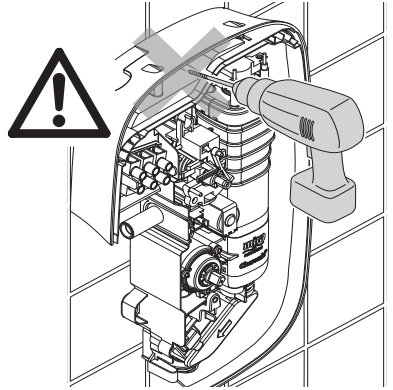
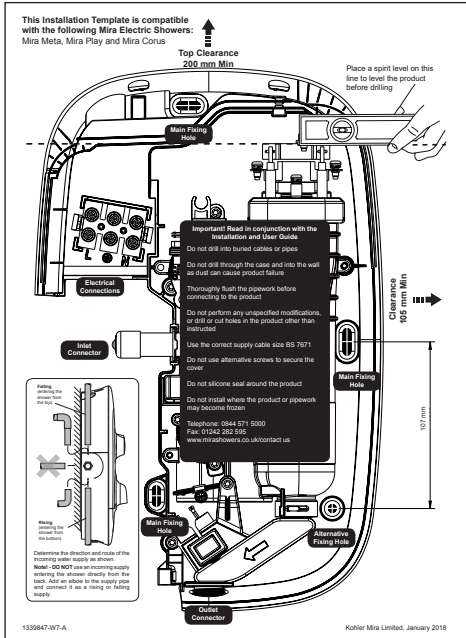

Use template provided to mark and drill required fixing holes. **Do not** drill through the shower unit into the wall. Plaster and brick dust will damage internal components of product.

6

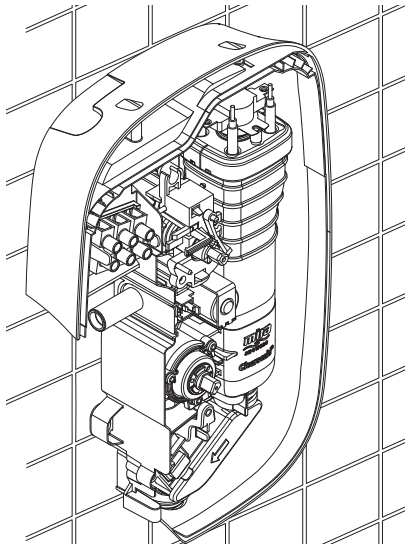

Secure the shower to the wall with all the fixing screws and wall plugs (supplied) or appropriate wall fixings (non-corrosive) for your installation.

7

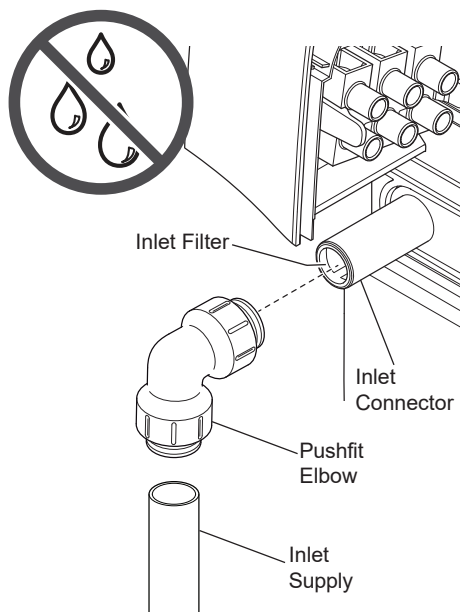

Check the inlet filter is in position before connecting the inlet supply.

Connect the inlet supply pipe to the inlet connector using a push fit elbow or an elbow with compression nuts and olives. Turn the water supply **ON** and check the shower unit for leaks.

Important! DO NOT use push fit elbows that require specialist tools for removal. Access to the inlet filter is required periodically and so any connector needs to be easily removed for maintenance.

Note! When making connections to the shower do not use jointing paste products as damage to the shower will occur.

8

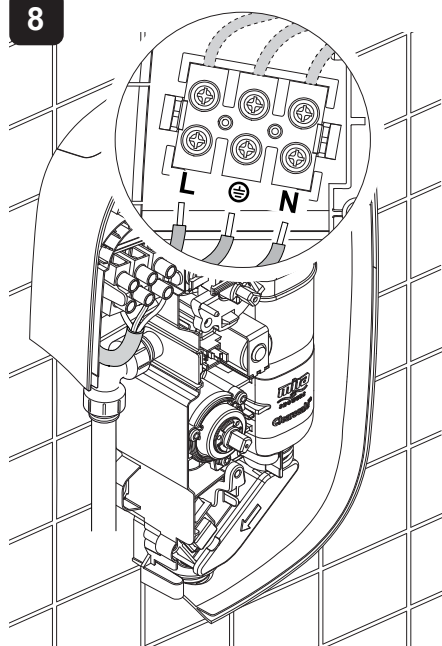

Strip back sufficient outer cable insulation to enable routing to terminal block.

Insert the wires into the terminal block.

Tighten the screws in the terminal block, make sure the wires are secure and tight.

Ensure the earth bonding complies with the relevant regulations.

L (Live) = Brown wire

⊕ (Protective Earth) = Green wire

N (Neutral) = Blue wire

9

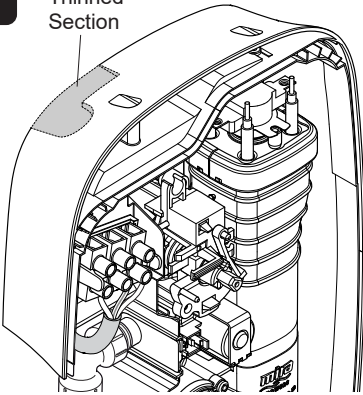
Thinned
Section

For falling or rising supplies the cover has thinned sections on the top and bottom that can be removed to allow entry of the supply pipe and electrical cables. **Note!** **DO NOT** extend beyond thinned section.

10

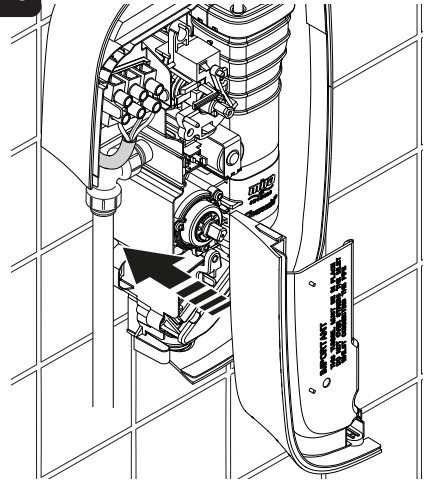

Refit the service tunnel.

11

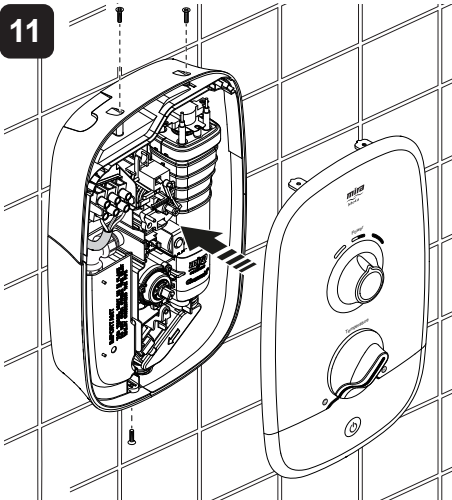

Make sure that the control dials are aligned with the spindles and replace the cover.

Tighten the three cover screws.

Warning! Do not use alternative screws to secure the cover. This can cause internal damage to the appliance. Do not seal around the back of appliance.

12

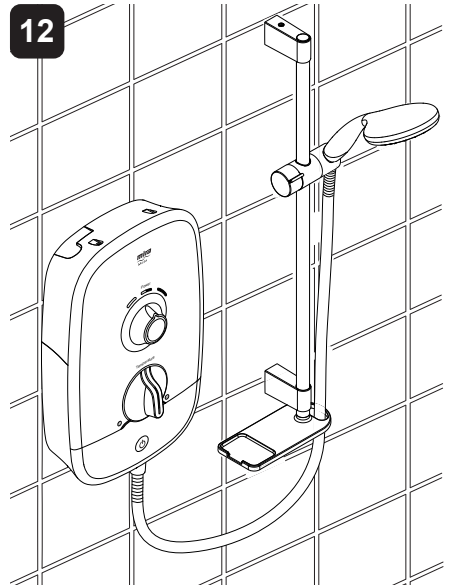

Install the shower fittings Refer to the separate Shower Fittings Installation and User Guide. **Note!** The shower must be commissioned before use. Refer to **COMMISSIONING**.

Commissioning

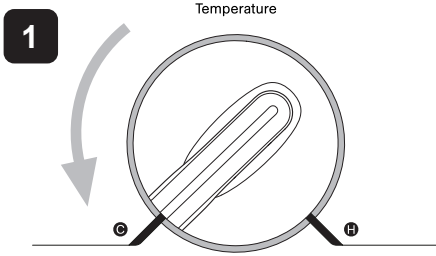

Make sure that temperature control is in the full cold position.

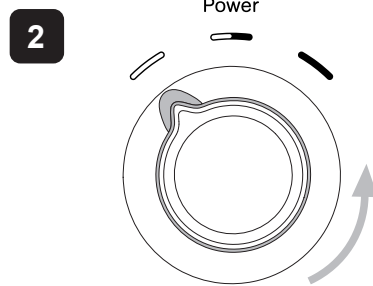

Turn the power control to low as shown.

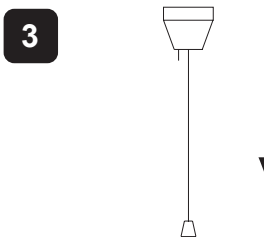

Switch on the electrical supply.

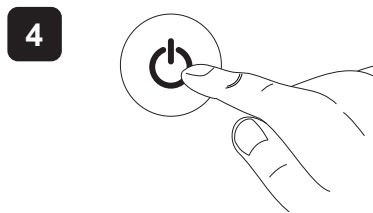

Push the **START/STOP** button to turn ON the appliance.

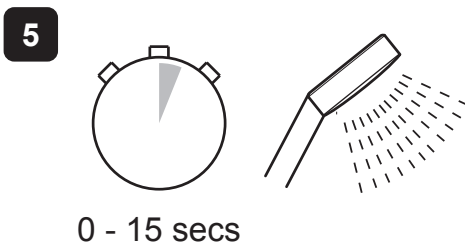

Water flows freely within a few seconds, temperature remains cool.

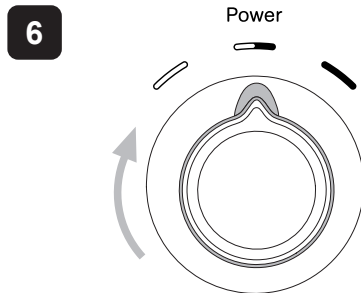

Turn power control to Medium as shown.

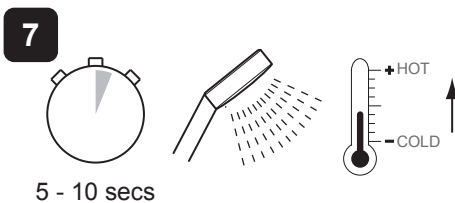

Temperature will rise slightly.

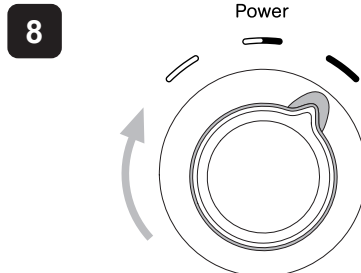

Turn power control to High as shown.

9

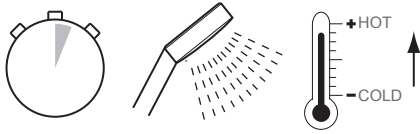

5 - 10 secs

Temperature will rise further.

10

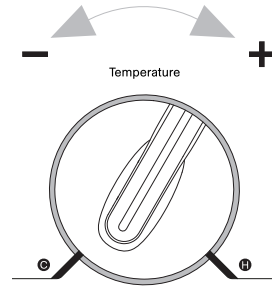

Adjust temperature as required.

Note! Flow rate will reduce when temperature setting is increased.

Note! A slight hissing sound may be heard from the shower during operation. High mains water pressure and high shower temperatures will affect the tone. This is quite normal in use.

11

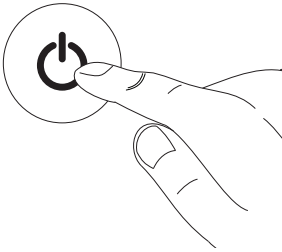

Push the **START/STOP** button to turn OFF appliance.

12



Switch off the electrical supply.

13

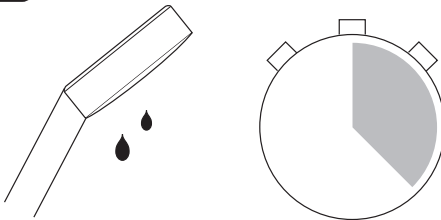

A small amount of water may continue to drain over a few minutes. Wait for the product to fully shut down. (This may take few seconds)

Operation

Read the section “**Important Safety Information**” first.

1



Switch on the electrical supply.

2

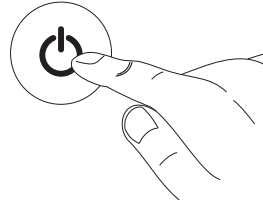

Push the **START/STOP** button to turn ON the appliance.

3

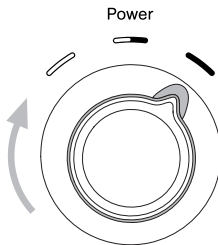

Turn the power control to the desired position.

4

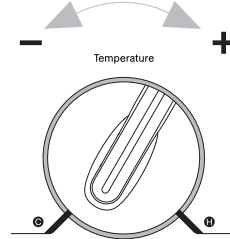

Adjust the temperature as required.

5

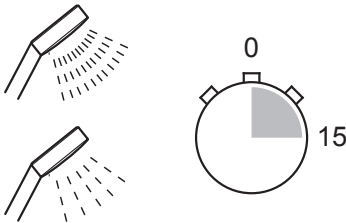

Allow 10 - 15 secs for any temperature adjustments to stabilise and reach the showerhead.

6

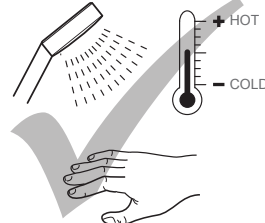

Check the water temperature before entering shower.

7

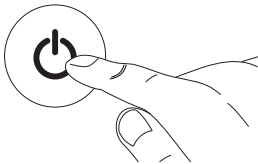

Push the **START/STOP** button to turn OFF appliance. Wait for the product to fully shut down. (This may take few seconds)

8



Switch off the electrical supply.

9

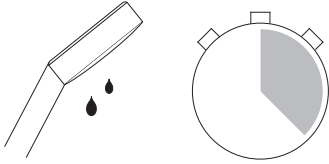

A small amount of water may continue to drain over a few minutes.

WARNING! Turning the shower off and back on during showering may result in unstable temperatures at the showerhead. Always ensure the temperature has stabilised before re-using the shower.

Note! A slight hissing sound may be heard from the shower during operation. High mains water pressure and high shower temperatures will affect the tone. This is quite normal in use.

The Effect of Seasonal Changes

Incoming mains water temperature is not constant throughout the seasons of the year i.e. cooler during the winter, warmer during the summer. These changes can affect the outlet temperature of the shower, therefore the shower temperature may need to be increased or decreased to maintain the desired showering temperature.

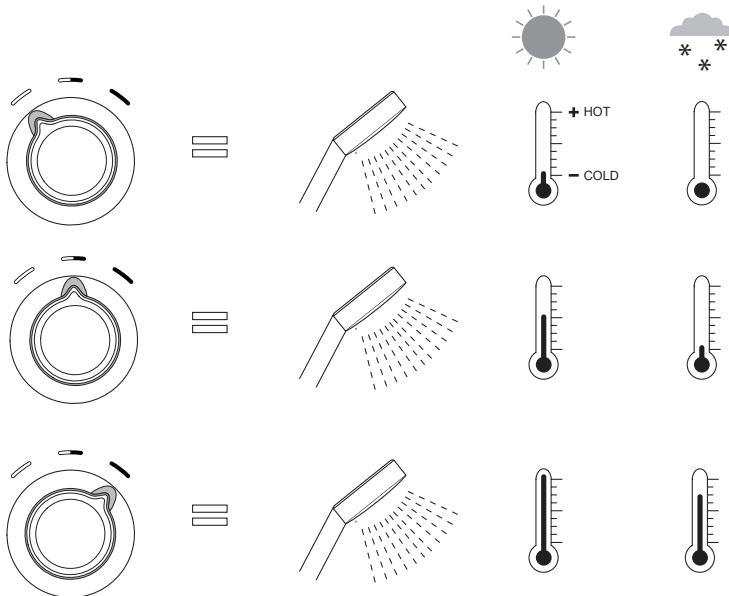

For a cold shower select LOW

For a summer warm shower select ECO

For a winter warm shower select HIGH

Adjust the temperature as required

Flow rate will reduce when temperature setting is increased.

The Effect of Other Water Devices

Example of how shower temperature stabilises due to pressure changes.

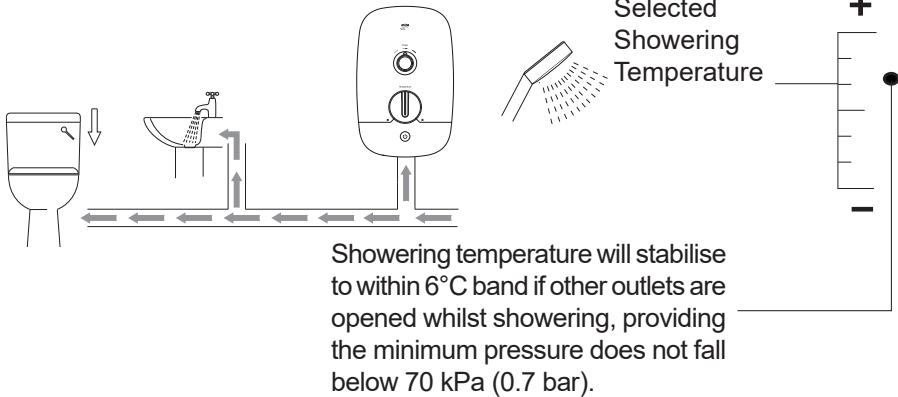

Showering temperature will stabilise to within 6°C band if other outlets are opened whilst showering, providing the minimum pressure does not fall below 70 kPa (0.7 bar).

Water inlet pressure fluctuations due to other draw offs (e.g. flushing toilet) will cause the showering temperature to increase.

User Maintenance

In the event of a malfunction of the shower, a fault finding table is provided in this guide detailing possible causes and remedies that may be carried out by non-qualified personnel.

WARNING - TO REDUCE THE RISK OF FIRE, ELECTRIC SHOCK, INJURY OR PRODUCT DAMAGE:

1. There are no user serviceable parts inside the shower. Only qualified, competent personnel should remove the front cover, mains connections are exposed when the cover is removed.
2. Switch the shower off at the isolator switch before performing any user maintenance or before cleaning the shower.
3. **DO NOT** allow children to perform user maintenance including cleaning of the shower without supervision.
4. **DO NOT** use the showerhead to clean the shower.
5. If the shower is not to be used for a long period, the electrical supply and water supply to the shower should be isolated. If the shower or pipework is at risk of freezing during this period a qualified, competent person should drain them of water.

Cleaning

Always read the **IMPORTANT SAFETY INFORMATION** for your shower.

Cleaning the showerhead

Many household and commercial cleaners, including hand and surface cleaning wipes contain abrasive and chemical substances that can damage plastics, plating and printing and should not be used. These finishes should be cleaned with a mild washing up detergent or soap solution, and then wiped dry using a soft cloth.

De-scaling the Showerhead and inspecting the hose:

It is **IMPORTANT** to keep the showerhead and hose clean and free from blockage to make sure your shower performs to its optimum. The showerhead **MUST** be regularly cleaned and the hose **MUST** be regularly inspected to ensure there is no internal collapse or blockage that could reduce the flow.

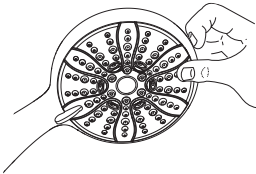

Use your thumb or a soft cloth to wipe any limescale from the soft nozzles.

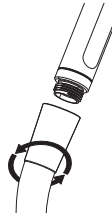

Unscrew the hose from the showerhead and the shower outlet.

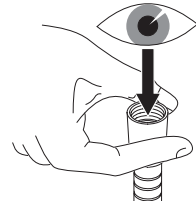

Inspect the hose.

Warning! Failure to keep the showerhead nozzles clear or inspect the hose for blockage or internal/external collapse can restrict the flow rate from the shower. This may cause damage to the shower or result in the temperature delivered to the user rising to unsafe levels with a risk of scalding. You **MUST ALWAYS** check the temperature before using the shower.

Fault Diagnosis

If the malfunction has not been detailed in the fault finding table or it was not possible to correct the malfunction, professional assistance may be required. Contact your installer if newly installed or refer to the Customer Support page on 'What to do if something goes wrong'.

Symptom	Power Control Position	Possible Cause	Possible Remedy
Shower fails to operate	ANY	Isolator switch in the off position	Isolator switch in the off position
		Fuse blown or MCB/RCD tripped, indicating possible electrical fault	Renew the fuse or reset the MCB/RCD. If fault persists, contact your installer
Shower cycles from hot to cold	MEDIUM / HIGH	The hose or showerhead is blocked	De-scale showerhead, check hose for kinks or damage and replace if necessary. Refer to the ' USER MAINTENANCE ' section of this guide
		Water pressure below minimum required for shower operation	Make sure incoming mains water stopcock and/or shower isolating valve is fully turned on
		Temperature control or heater setting too high	Turn the power control to Eco or turn the temperature control until a cooler temperature is achieved
Unable to select a cool enough shower	MEDIUM / HIGH	Due to high water supply temperature, the heater setting may be too high	Turn the power control to Eco or turn the temperature control until a cooler temperature is achieved
		The hose or showerhead is blocked	De-scale showerhead, check hose for kinks or damage and replace if necessary. Refer to the ' USER MAINTENANCE ' section of this guide
Low flow	ANY	The hose or showerhead is blocked	De-scale showerhead, check hose for kinks or damage and replace if necessary. Refer to the ' USER MAINTENANCE ' section of this guide
		Other outlets (e.g. toilet, garden hose, washing machine, etc.) drawing water while the shower is being used	Turn off other appliances whilst shower is in use
Operation of Temperature Control has little or no effect on water temperature	MEDIUM / HIGH	The hose or showerhead is blocked	De-scale showerhead, check hose for kinks or damage and replace if necessary. Refer to the ' USER MAINTENANCE ' section of this guide

Servicing

WARNING

There are no user serviceable parts inside the shower.

Servicing of the shower must only be carried out by qualified, competent personnel following the instructions provided in this guide and those provided with any spare part.

Before replacing any parts, ensure that the underlying cause of the malfunction has been resolved.

Cleaning the Inlet Filter

Warning! Isolate the electrical and water supplies before removing the cover.

Remove the cover and the service tunnel.

Remove the elbow from the inlet connector.

Note! Depending on your installation it may be necessary to remove the shower from the wall to allow filter removal.

In this case isolate all supplies and follow steps 6 - 8 in reverse order as detailed in section: **'INSTALLATION'**.

Prise the filter from the inlet connector assembly.

Rinse the filter under a running tap to remove any lodged particles. If necessary, use a kettle descaler in accordance with the manufacturer's instructions.

Refit the inlet filter and follow steps 7 - 11 as described in section: **'INSTALLATION'**.

Note! If the shower was removed from the wall, steps 6, 7, 8, 10 and 11 will need to be followed as described in section: **'INSTALLATION'**.

Follow the steps detailed in section: **'COMMISSIONING'** to prepare the shower for use.

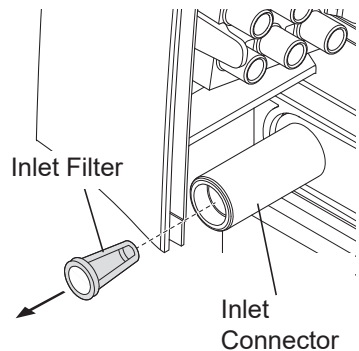
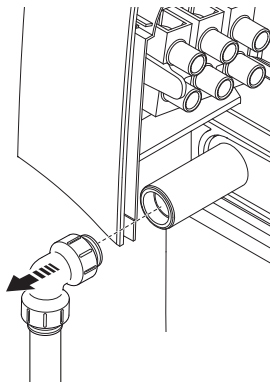

Spare Parts

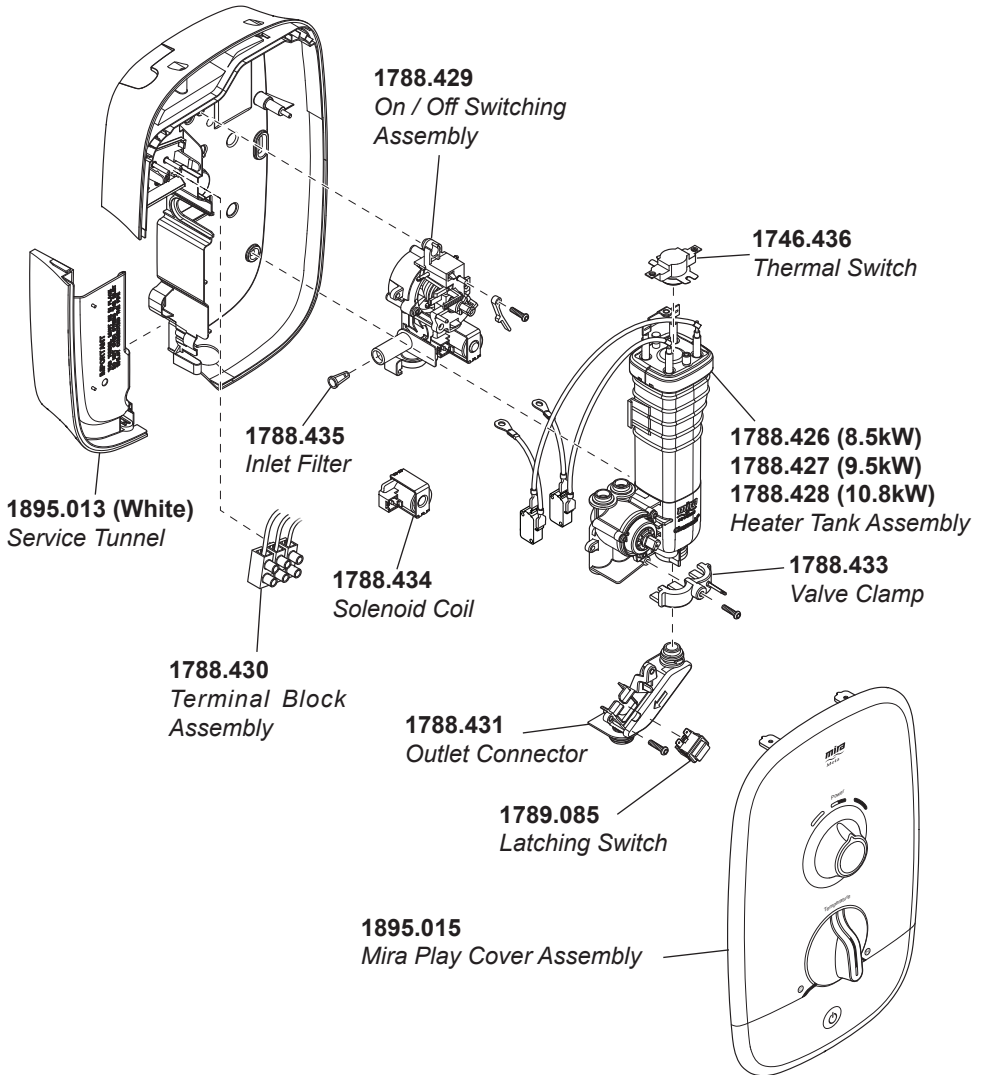

1693.331 Component Pack (Not illustrated)

1895.018 Wire Pack (Not illustrated)

1788.436 Screw Pack (Not illustrated)

Customer Support

Guarantee

Your product has the benefit of our manufacturer's guarantee which starts from the date of purchase. This guarantee only applies in the United Kingdom and Republic of Ireland.

Activating Your Guarantee

Registering your guarantee is quick and simple. To ensure your product is covered, please register online.



Scan the QR code to activate your guarantee now or call 0800 5978551 within 30 days of purchase (UK only).

What is Covered:

- The guarantee applies solely to the original installation under normal use.
- The product must be installed and maintained in accordance with the instructions given in this guide.
- Servicing must only be undertaken by us or our appointed representative.
- Repair under this guarantee does not extend the original expiry date. The guarantee on any replacement parts or product ends at the original expiry date.
- For shower fittings or consumable items we reserve the right to supply replacement parts only.

The guarantee does not cover:

- Call out charges for non product faults (such as damage or performance issues arising from incorrect installation, improper use, inappropriate cleaning, lack of maintenance, build up of limescale, frost damage, chemical attack, corrosion, system debris or blocked filters) or where no fault has been found with the product.
- Water or electrical supply, waste and isolation issues.
- Routine maintenance or replacement parts to comply with the requirements of Building / Plumbing / Electrical Standards or Schemes.
- Compensation for loss of use of the product or consequential or indirect loss of any kind.
- Damage or defects caused if the product is repaired or modified by persons not authorised by us or our appointed representative.
- Accidental or wilful damage.
- Products purchased ex-showroom display.
- Disinfection or descaling to reduce bacterial growth or contamination.

What to do if something goes wrong

If your product is not working correctly please refer to this manual for fault diagnosis and to check that it is installed and commissioned in accordance with our instructions. If this does not resolve the issue, our Customer Services team are here to help get you back up and running. To help us solve your problem quickly, please have your product name, power rating (if applicable) and date of purchase to hand.

Visit www.mirashowers.co.uk

Visit our website to register your guarantee, book a service visit, diagnose faults and purchase products.

Spares and Accessories

We stock a full range of spare parts and fittings and are all available to purchase either online or over the phone. Our online spare parts selector tool will help you quickly and easily identify the spare part for your product.

Visit www.mirashowers.co.uk/parts-accessories

Replacements and Repairs

In the unlikely event that your product needs a repair, our nationwide repairs and installation team are here to help. You can book a convenient date and time online.



Scan the QR code to book a service visit now or visit www.mirashowers.co.uk/support/repair-services/repair-service

We also offer a comprehensive replacement service for when your product needs a little refresh, visit our website or contact our team for more information on our replacement services.

Help us improve

Your experience is important to us and your review (whether good, bad or otherwise) will be posted on Trustpilot.com immediately to help other people make more informed decisions.

Visit uk.trustpilot.com/review/www.mirashowers.co.uk

Need to get in touch?

UK

T: 0800 001 4040
E: askus@mirashowers.com
www.mirashowers.co.uk

Eire

T: 01 531 9337
E: customerserviceire@mirashowers.com
www.mirashowers.ie

Mira is a registered trade mark of Kohler Mira Limited.

The company reserves the right to alter product specifications without notice.

Registered Office:
Cromwell Road,
Cheltenham,
Gloucestershire
GL52 5EP

EU Importer address
K/E S.A.S.
3 rue de Brennus,
93631, La Plaine Saint-Denis,
France



mira
SHOWERS