



Select Flex

Introduction

Thank you for purchasing a quality Mira product. To enjoy the full potential of your new product, please take time to read this guide thoroughly, having done so, keep it handy for future reference.

Mira shower fittings are designed to give a satisfactory shower over a range of pressures. These fittings are suitable for pressures between 0.1 and 5.0 bar.

These fittings can be corner mounted, maximising space in small enclosures.

General

1. Make sure that the shower fittings are installed by a competent installer.
2. Installations must comply with Water Regulations (Bye-Laws, Scotland), and any other Local Regulations and Building Regulations in force at the time of installation.
3. Before installation carefully inspect the new fixture for any signs of damage.
4. The shower fittings should be positioned at a convenient height for all the family. Position the showerhead to spray across rather than towards the opening of the cubicle and also away from the shower control. Avoid layouts where the shower hose will be sharply kinked. This may reduce the life of the hose.
5. A hose retaining ring is supplied to prevent the showerhead from dropping below the spill over level of the bath or shower, which could lead to contamination from backsiphonage. The supplied hose retaining ring should meet the great majority of user requirements for shower installations with flexible outlet fittings. However, there will be occasions when the hose retaining ring will not provide a suitable solution. In these instances an **outlet** double check valve, e.g. the Mira DCV-H, **must** be fitted. The inclusion of the Mira DCV-H will increase the required supply pressure typically by 0.1 bar.
6. **Do not** fit any form of flow control in the outlet pipework.
7. Special consideration should be given to the fixing arrangements when installing onto a dry lined, stud partition, shower cubicle or laminated panel wall structures. Installers may wish to obtain alternative proprietary cavity fixings, or choose other options, however, these methods of fixing are beyond the scope of this guide.

Spray Plate

The showerhead has been fitted with a low capacity spray plate, suitable for pressures between 0.06 and 0.5 bar (0.6 to 5 m head). For high pressure installations (e.g. combination boilers) we advise that you fit the high capacity spray plate (supplied).

Cleaning

Many household cleaners contain abrasives and chemical substances, and should not be used for cleaning plated or plastic fittings.

These finishes should be cleaned with a mild washing up detergent or soap solution, and then wiped dry using a soft cloth.

The showerhead included with these fittings has been specifically designed for use in hard water areas. The design incorporates an automatic self drain action and pins to resist and clear limescale build up. The face of the showerhead is cleared with pins coming through the spray plate to stop the build up of limescale. The pressure of the water moves the spray plate over the pins which enables the holes in the showerhead to be automatically cleaned. As this is automatic there is generally no need to touch the pins. If a need arises, care should be taken as although the pins are blunt-ended and perfectly safe, they may feel uncomfortable to the touch.

Spare Parts

Spare parts are available from authorised stockists or merchants (locations on request) or direct from Mira Customer Services, our contact details can be found on the back cover of this guide.

INSTALLATION

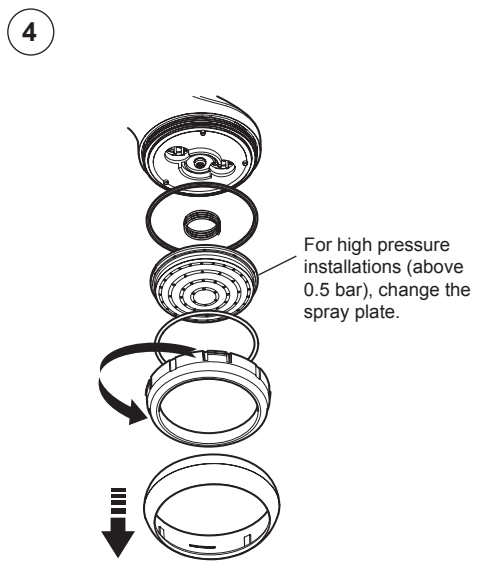
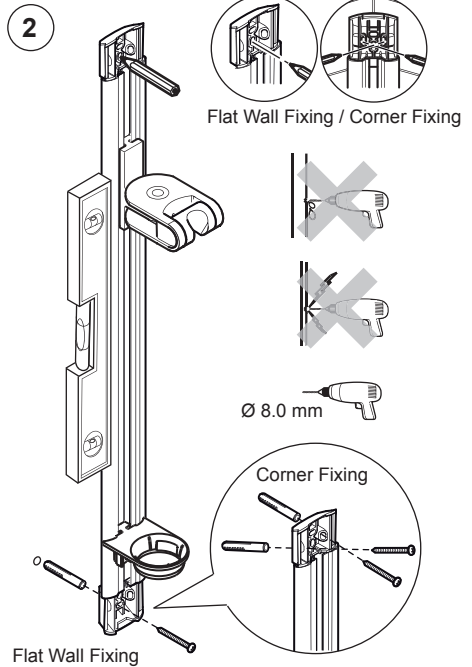
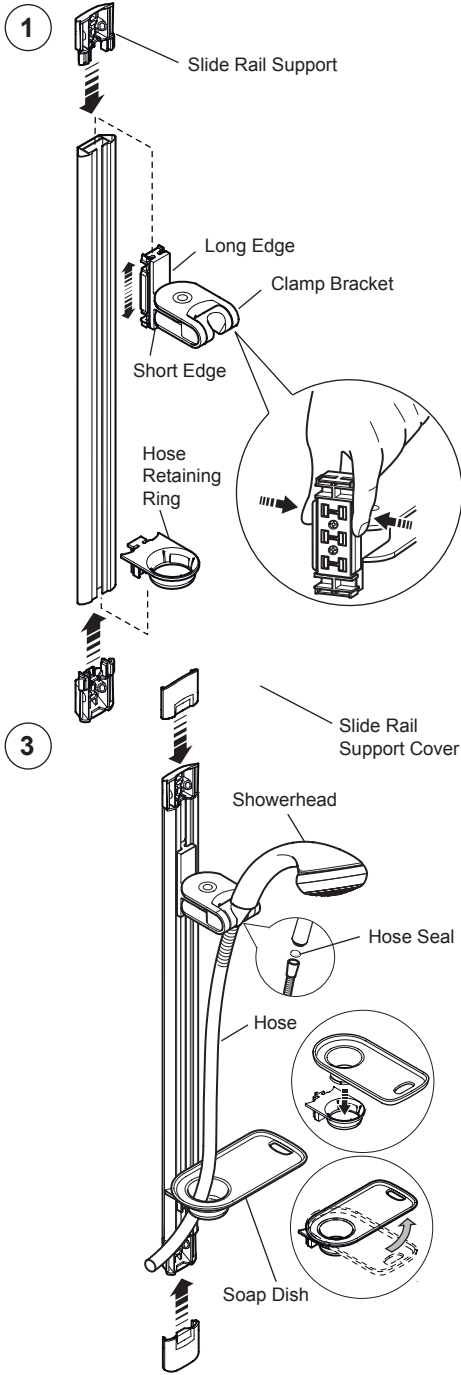

SPARE PARTS

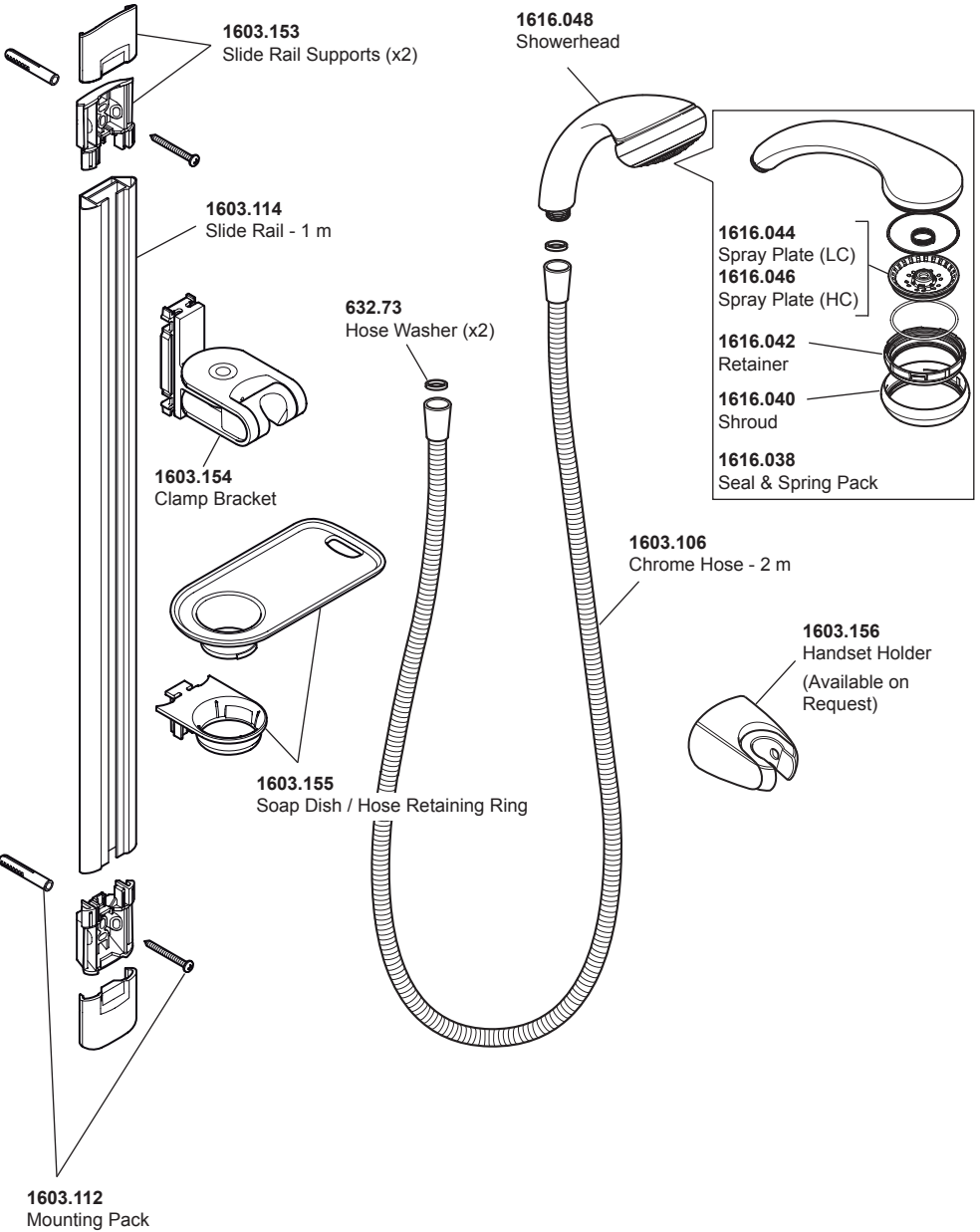

CUSTOMER SERVICE

Guarantee

Your product has the benefit of our manufacturer's 1 year guarantee which starts from date of purchase.

Within the guarantee period we will resolve defects in materials or workmanship, free of charge, by replacing parts or product as we may choose.

This guarantee is in addition to your statutory rights and is subject to the following conditions :

- The product must be installed and maintained in accordance with the instructions given in this user guide.
- Replacement under this guarantee does not extend the original expiry date. The guarantee on any replacement parts or product ends at the original expiry date.

The guarantee does not cover:

- Non product faults (such as damage or performance issues arising from incorrect installation, improper use, inappropriate cleaning, lack of maintenance, build up of limescale, frost damage, corrosion, system debris or blocked filters) or where no fault has been found with the product.
- Accidental or wilful damage.
- Compensation for loss of use of the product or consequential loss of any kind.
- Damage or defects caused if the product is repaired or modified by persons not authorised by us or our appointed representative.

What to do if something goes wrong

If your product does not function correctly when you first use it, check that it is installed and commissioned in accordance with the instructions in this manual.

If this does not resolve the issue, contact us for help and advice.

Helpdesk Service

Our Customer Services Team is comprehensively trained and can offer help and advice, spare parts and accessories. We will need you to have your model name, model number and date of purchase.

Please provide your model name and date of purchase.

Mira Showers Website (www.mirashowers.co.uk)

From our website you can download additional user guides, diagnose faults, purchase our full range of accessories and popular spares and refer to our FAQ's.

Spares and Accessories

We hold the largest stocks of genuine Mira spares and accessories.

Contact us for a price or visit our website to purchase items from our accessory range and popular spares.

To Contact Us:

UK

Telephone: 0844 571 5000

Fax: 01242 282595

Email – Visit www.mirashowers.co.uk/contactus

By Post: Mira Customer Services Dept, Cromwell Road, Cheltenham, Gloucestershire GL52 5EP

Eire Only

Telephone: 01 531 9337

E-mail – CustomerServiceEire@mirashowers.com

Mira is a registered trade mark of
Kohler Mira Limited.

The company reserves the right to alter
product specifications without notice.



FM 14648

mira
SHOWERS