

8.5, 9.5 & 10.8kW

mira

Play

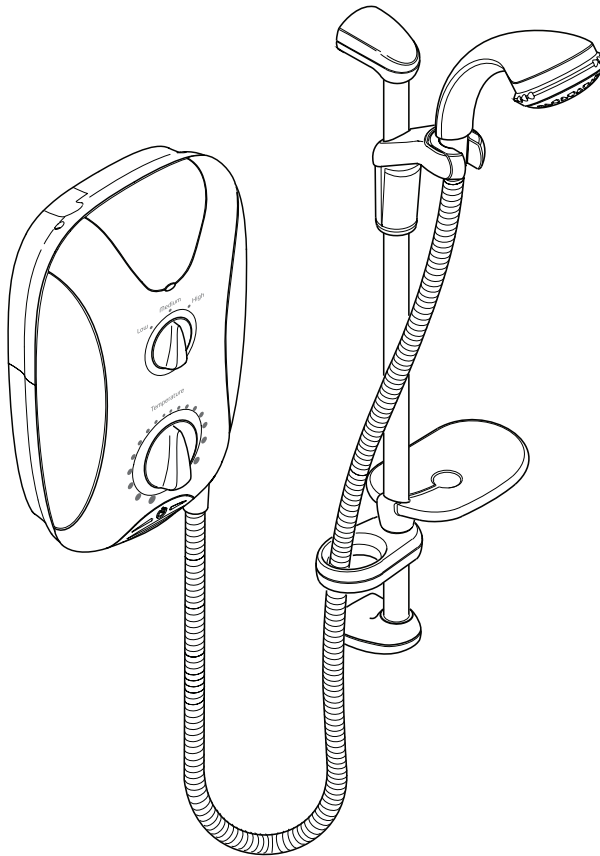

MIRA PLAY

ELECTRIC SHOWER

Installation & User Guide

These instructions are to be left with the user

CONTENTS

Patents and Design Registration.....	2
Introduction	3
Important Safety Information	4
Pack Contents Checklist	6
Specifications	7
Installer Instructions	8
Plumbing Checklist.....	8
Electrical Checklist	10
Installation	12
Mira Play	12
Mira Response Adjustable Shower Fittings.....	14
Commissioning	16
User Instructions	18
Fault Diagnosis.....	22
Maintenance.....	26
Dimensions	27
Wiring Diagram	28
Spare Parts	29
Mira Play	29
Mira Response Shower Fittings	31
Accessories	33
Notes	34
Customer Service.....	36

Patents and Design Registration

Design Registration:	000555768-0001
Patents:	GB: 2 237 860 Ireland: 64471

If you experience any difficulty with the installation or operation of your new Electric Shower, please refer to '**Fault Diagnosis**', before contacting Kohler Mira Ltd. Our telephone and fax numbers can be found on the back cover of this guide.

INTRODUCTION

Thank you for purchasing a quality Mira product. To enjoy the full potential of your new product, please take time to read this guide thoroughly. Having done so, keep it handy for future reference.

The Mira Play is an electric shower with separate controls for power selection and temperature/flow adjustment. A unique flow regulator stabilizes temperature changes caused by water pressure fluctuations. These can result from taps being turned on or off, or toilets being flushed. An individual light indicates “POWER ON”.

This shower comes complete with a set of Mira Response Adjustable Shower Fittings.

Mira Play 8.5 kW- A 8.5 kW 240 V AC (7.8 kW 230 V AC) heater.

Mira Play 9.5 kW- A 9.5 kW 240 V AC (8.7 kW 230 V AC) heater.

Mira Play 10.8 kW- A 10.8 kW 240 V AC (9.9 kW 230 V AC) heater.

Guarantee

For **domestic installations**, Mira Showers guarantee the Mira Play against any defect in materials or workmanship for a period of **two** years from the date of purchase (shower fittings for one year).

For **non-domestic installations**, Mira Showers guarantee the Mira Play against any defect in materials or workmanship for a period of **one** year from the date of purchase.

For terms and conditions refer to section “**Customer Services**”.

Mira Response Adjustable Shower Fittings

An adjustable spray handset with three different spray actions (start, soothe and force), supplied complete with flexible hose, clamp bracket assembly, slide bar, supports, soap dish, and hose retaining ring. Available in white/chrome finish.

Recommended Usage	
Domestic	✓
Light Commercial	✓
Heavy Commercial	✗
Healthcare	✗

IMPORTANT SAFETY INFORMATION

Installation must be carried out in accordance with these instructions, and must be conducted by designated, qualified and competent personnel.

1. Warning!

This shower can deliver scalding temperatures if not operated, installed or maintained in accordance with the instructions, warnings and cautions contained in this guide and on or inside the appliance.

If you require a thermostatic shower Mira produce a range which also limit the maximum temperature, for more information our contact details can be found on the back cover of this guide.

- 1.1. Products manufactured by us are safe and risk-free, provided that they are installed, used and maintained in good working order, in accordance with our instructions and recommendations.
- 1.2. Isolate the electrical and water supplies before commencing installation. The electricity must be turned off at the mains and the appropriate circuit fuse removed, if applicable.
- 1.3. Mains connections are exposed when the cover is removed.
- 1.4. Refer to the wiring diagram before making any electrical connections (refer to the wiring diagram at the back of this guide).
- 1.5. Make sure that any pipework that could become frozen is properly insulated.
- 1.6. Having completed the installation, make sure that the user is familiar with the operation of the appliance.
- 1.7. Make sure that this guide is left with the user.
- 1.8. **DO NOT** commission this appliance if water leaks from the unit or the heater tank pressure relief valve.
- 1.9. **DO NOT** fit any form of outlet control (e.g. Trigger handset) as the outlet acts as a vent for the tank body. Only Mira recommended outlet fittings should be used.
- 1.10. Make sure all electrical connections are tight, to prevent overheating.
- 1.11. **Warning! DO NOT** operate this appliance if it is frozen. Allow the appliance to thaw before using. The shower unit must not be fitted where it may be exposed to freezing conditions.
- 1.12. This product is not suitable for areas with high humidity (i.e steam rooms). Please consult your installer.
- 1.13. **THIS APPLIANCE MUST BE EARTHED. MAKE SURE SUPPLEMENTARY BONDING COMPLIES WITH THE "REQUIREMENTS FOR ELECTRICAL INSTALLATIONS"**.

The installation must be in accordance with the current edition of 'The Plugs and Sockets etc. (Safety) Regulations' in force at the time of installation, this Mira Play is intended to be permanently connected to the fixed electrical wiring of the mains system.

2. Caution!

- 2.1. Read all of these instructions and retain this guide for later use.
- 2.2. The electrical installation must comply to “BS 7671 - Requirements for Electrical Installations”, commonly referred to as the IEE Wiring Regulations - Part 7, or any particular regulations and practices, specified by the local electricity supply company.
- 2.3. The plumbing installation must comply with the requirements of UK Water Regulations/Bye-laws (Scotland), Building Regulations or any particular regulations and practices, specified by the local water company or water undertakers.
- 2.4. Make sure that you fully understand how to operate this shower and make sure that it is properly maintained in accordance with the instructions given in this manual.
- 2.5. Anyone who may have difficulty understanding or operating the controls of any shower should be attended whilst showering. Particular consideration should be given to:
 - 2.5.1. The young.
 - 2.5.2. The elderly.
 - 2.5.3. The infirm.
 - 2.5.4. The disabled.
 - 2.5.5. Anyone who suffers from a medical condition that can result in temporary incapacity (e.g. epilepsy or blackouts).
 - 2.5.6. Anyone inexperienced in the correct operation of the controls.
- 2.6. Children should be supervised to ensure that they **DO NOT** play with the appliance.
- 2.7. Sunburn or skin conditions can increase your sensitivity to hot water. Make sure that you set the shower to a cooler temperature.
- 2.8. If any of the following conditions occur, isolate the electricity and water supplies and refer to “To contact us”, on the back page of this guide.
 - 2.8.1. If the cover is not correctly fitted and water has entered the appliance case.
 - 2.8.2. If the case is damaged.
 - 2.8.3. If the appliance begins to make an odd noise, smell or smoke.
 - 2.8.4. If the appliance shows signs of a distinct change in performance, indicating a need for maintenance.
 - 2.8.5 **DO NOT** operate this appliance if water leaks from this appliance.
- 2.9. When this appliance has reached the end of its serviceable life, it should be disposed of in a safe manner, in accordance with current local authority recycling, or waste disposal policy.

PACK CONTENTS CHECKLIST



Tick the appropriate boxes to familiarize yourself with the part names and to confirm that the parts are included.

Mira Play

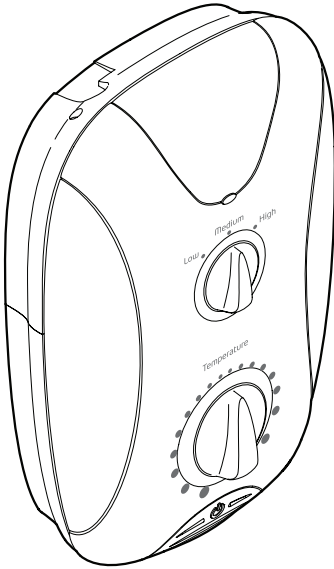

1 x Mira Play Electric Shower



3 x Fixing Screws



3 x Wall Plugs

Documentation

1 x Installation Template

1 x Guarantee and Registration Card

Mira Response Adjustable Shower Fittings

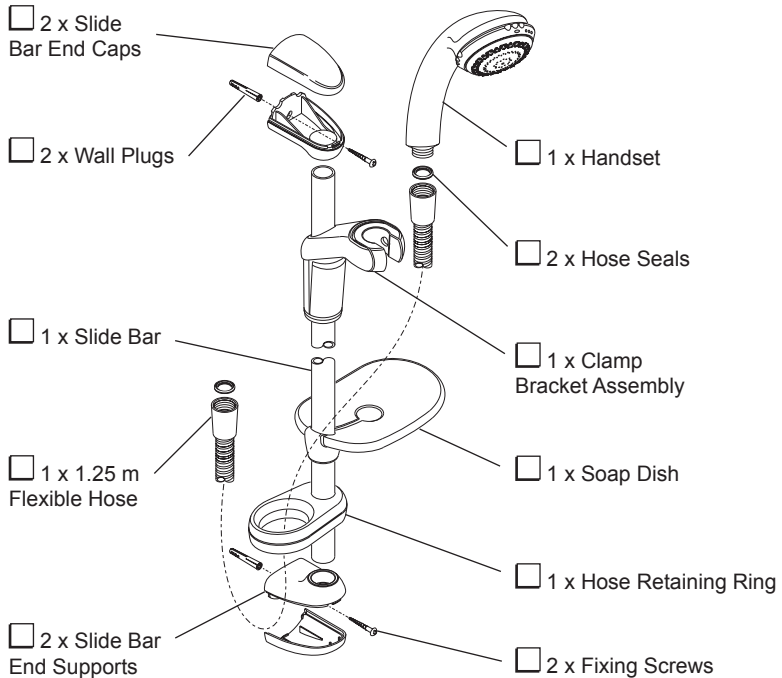

SPECIFICATIONS

1. Plumbing

- 1.1. Minimum maintained inlet pressure:
8.5 kW, 9.5 kW = 70 kPa (0.7 bar) 10.8 kW = 100 kPa (1.0 bar)
- 1.2. Maximum static inlet pressure of 1000 kPa (10 bar).
- 1.3. Minimum static inlet pressure of 50 kPa (0.5 bar) to keep the inlet valve closed.

2. Electrical

- 2.1. The Mira Play 8.5 kW and 9.5 kW requires a 40 Amp fuse.
- 2.2. The Mira Play 10.8 kW requires a 45 Amp fuse.
- 2.3. The terminal block will accept cable sizes up to 16 mm².
- 2.4. The Mira Play is suitable for installation in zone 1 and is rated IP X4.

3. Standards and Approvals

- 3.1. The Mira Play complies with all relevant directives for CE marking.

INSTALLER INSTRUCTIONS

Read the section “Important Safety Information” first.

Plumbing Checklist

1. Minimum maintained inlet pressure 8.5 kW and 9.5 kW = 70 kPa (0.7 bar).
Minimum maintained inlet pressure 10.8 kW = 100 kPa (1.0 bar).
Maximum static inlet pressure = 1000 kPa (10 bar).
2. Water treatment device (if required).
3. Free flowing isolating valve.
4. Positioned over water catchment area.
5. Fitted to finished wall surface.
6. No sharp hose kinks.
7. Fittings positioned with greater than 25 mm gap or outlet double checkvalve fitted.
8. Supply pipework flushed clear.
9. Watertight inlet connection and fittings.
10. Cover secured correctly.

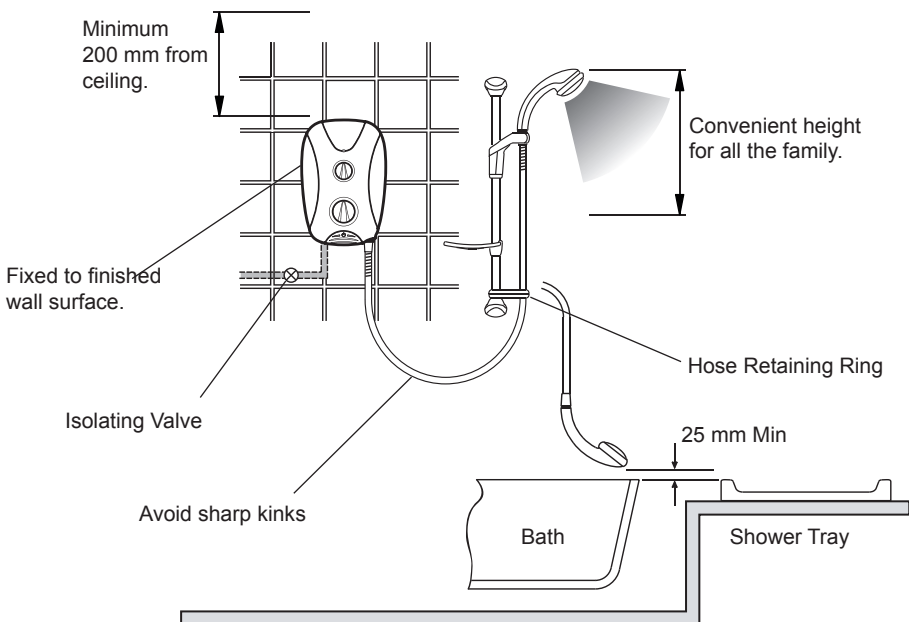

Plumbing (checklist in detail)

1. The appliance is designed to operate with a **minimum maintained inlet pressure of 70 kPa (0.7 bar)**, for 8.5 kW and 9.5 kW and **100 kPa (1.0 bar)** for 10.8 kW up to a **maximum static inlet pressure of 1000 kPa (10 bar)**.
2. When installed in very hard water areas (above 200 ppm temporary hardness) your installer may advise the installation of a water treatment device, to reduce the effects of limescale formation. Your local water company will be able to advise the hardness of water in your area.
3. It is recommended that a non-restrictive (free flowing) isolating valve is fitted as part of the cold water supply pipe to allow the complete maintenance of the appliance. Do not use a valve with a loose washer plate (jumper) as this can lead to the build up of static pressure.
4. The appliance is only suitable for installation within the shower area. It is fitted with a pressure relief device and must be positioned over a water catchment area with the controls at a convenient height for all users.
5. The appliance must be fitted onto a finished flat and even wall surface (this wall surface should be tiled or suitably waterproofed). Do not fit the appliance to the wall and tile up to the case. For safety requirements, an air gap must be left behind the appliance.
6. Avoid layouts where the shower hose will be sharply kinked. This may reduce the life of the hose.
7. A Hose Retaining Ring is supplied to prevent the handset from dropping below the spill-over level of the bath or shower tray, which could lead to contamination from back-siphoning. The supplied Hose Retaining Ring should meet the greater majority of user requirements for shower installations with flexible outlet fittings. However, there will be occasions where it will not provide a suitable solution. In these instances an outlet double checkvalve, e.g. a Mira DCV-H, must be fitted. This will increase the required supply pressure typically by 10 kPa (0.1 bar). See section "Accessories".
8. Supply pipework must be flushed to clear any debris before connecting to the appliance.
9. To avoid damage to the case when soldered fittings are used, pre-solder the pipework and fittings before connecting them to the inlet connector assembly. Refrain from applying excessive force when making any connections. Always provide mechanical support when making the plumbing connections.
10. The appliance is fitted with a plastic inlet compression assembly for connecting to a 15 mm supply pipe from the top, bottom or back. Double checkvalves, fitted in the inlet supply to the appliance, cause a pressure build-up, which could exceed the maximum static inlet pressure and damage the appliance.

Read the section “Important Safety Information” first.

Electrical Checklist

1. Electrical supply fuse and consumer unit are adequate for the product.
2. Shower unit is earthed.
3. The minimum required supply cable size must conform to BS 7671.
4. Double pole isolating switch.
5. **DO NOT** twist live or neutral cable cores.
6. Electrical connections are tightly secured.
DO NOT strain the terminal block.
7. Plumbing supply completed before electricity supply is turned on.

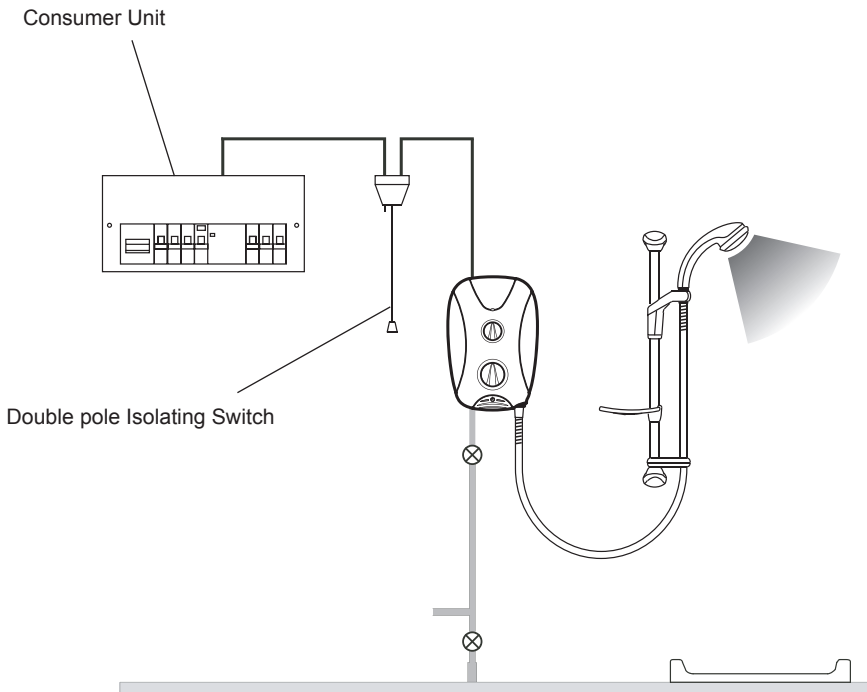

Electrical (checklist in detail)

1. In a domestic installation, the rating of the electricity supplier's fuse and the consumer unit must be adequate for the additional demand. All Mira Play electric showers are high power units, therefore it is essential to contact your electricity supplier to ensure that the supply is adequate for the product. Voltage drop due to local heavy demand will reduce the shower's performance.
2. The appliance **must be earthed** by connecting the supply cable's earth conductor to the earth terminal.
Supplementary bonding: Within the bathroom or shower room, all accessible conductive parts of electrical equipment and extraneous conductive parts (metal parts) that are likely to introduce earth potential, must be electrically bonded to earth. If the cable is not mechanically protected, the cable size must be a minimum of 4.0 mm² (2.5 mm² if mechanically protected). Use a suitable earth bonding strap to connect the earth terminal to 15 mm copper pipe. The installation must comply with the "Requirements for electrical Installations" in accordance with BS 7671.
3. Supply cable - see opposite.
Important! The shower circuit should be separated from other circuits by at least twice the diameter of the cable or conduit, and it should not be run through thermally insulating material or in locations where the ambient temperature is likely to exceed 30°C. If any of these conditions are unavoidable, it is necessary to determine the cable size which will prevent damage to the cable caused by overheating.
4. As a guide only, and in accordance with BS 7671 we recommend close circuit protection: i.e. 9.5 kW = 40 Amp.
A 30 mA Residual Current Device (RCD) **must** be included in the electrical circuit. This may be part of the consumer unit or a separate unit. A separate, permanently connected supply is taken from the consumer unit to the appliance through a double pole isolating switch, which has at least 3 mm of contact separation. The switch can be a ceiling mounted pullcord type within the shower room, or a wall mounted switch in an adjacent room.
5. **DO NOT** twist the individual cable cores of either the live or neutral conductors, as this will prevent them from entering the terminal block.
6. **DO NOT** exert strain on the terminal block. Make sure that the electrical connections are tightly screwed down.
7. **DO NOT** turn on the electrical supply until the plumbing has been completed.

INSTALLATION

Mira Play

Read the section “Important Safety Information” first.

- 

Electrical supply is turned off at the mains.
- 

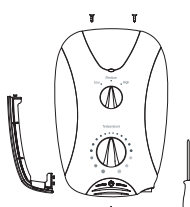
200 mm minimum gap from ceiling.
- 

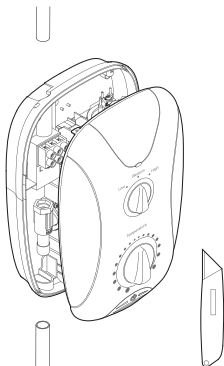
Remove three screws.
- 

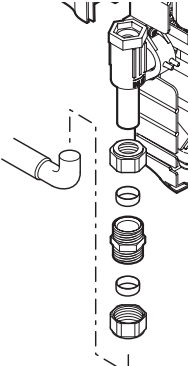
Remove Cover and determine supply pipe position.
- 

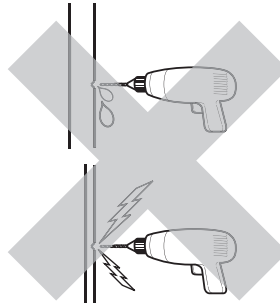
For back inlet use soldered elbow.
- 

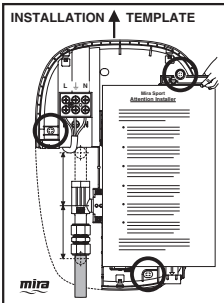
Caution! Do not drill into buried cables or pipes.
- 

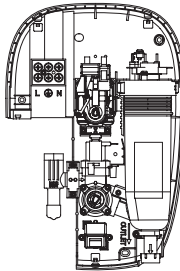
Drill and plug* the three holes using template.
- 

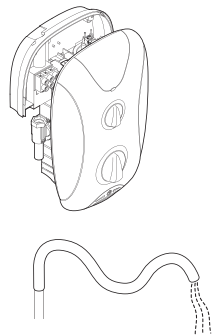
Fix appliance to wall.
- 

Flush a minimum of 10 litres through pipework.

* Alternative fixings for some wall structures are not supplied.

10.

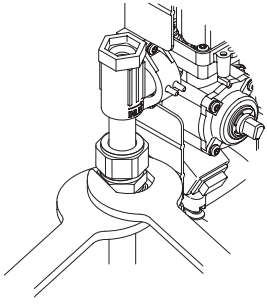

Connect supply pipe. **Do not overtighten!**

11.

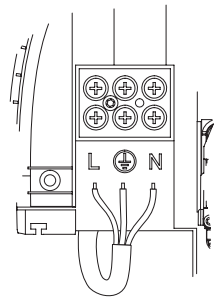

Feed cable into Case. Fit Earth sleeve (not supplied) and strip insulation.
Do not twist cable cores.

12.

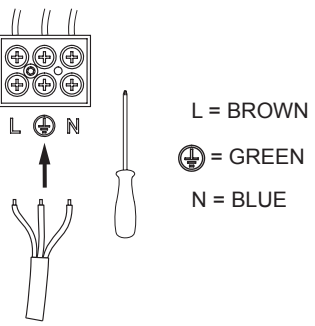

Firmly connect the conductors. **Do not** exert strain on the terminal block.

13.

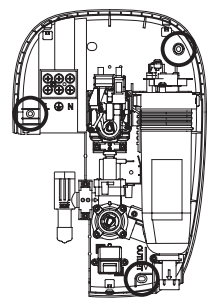

Make sure wires are clear of all mounting holes.

14.

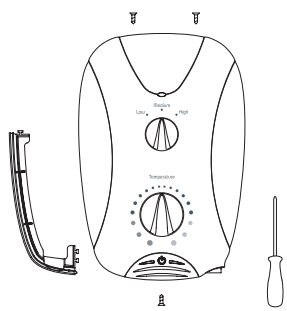

Refit the Service Tunnel and Cover. Make sure they fit correctly.
Do not overtighten screws.

15.

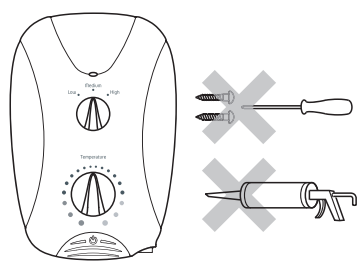

Do not use alternative screws to secure the Cover. This can cause internal damage to the appliance.
Do not seal around the back of appliance.

Mira Response Adjustable Shower Fittings

Read the section “Important Safety Information” first.

1.

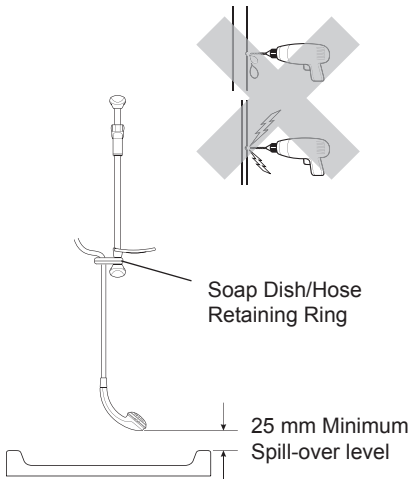

Position as shown to prevent back siphoning.

2.

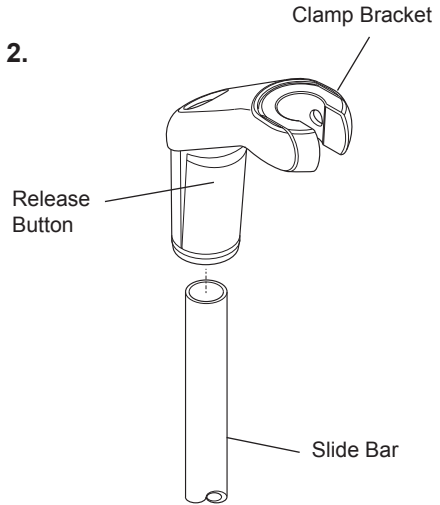

Depress release button **FULLY** and assemble Clamp Bracket. Release the button when in desired position.

3.

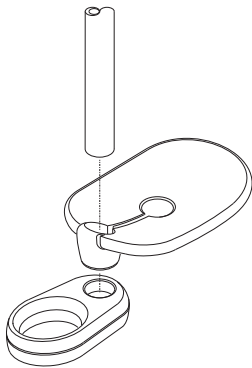

Slide the Soap Dish and the Hose Retaining Ring onto the Slide Bar below the Clamp Bracket.

4.

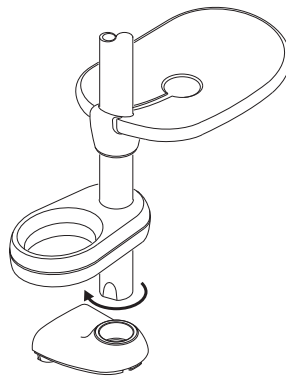

Fit both the top and bottom Supports. Make sure the slots are aligned to fit fully home.

5.

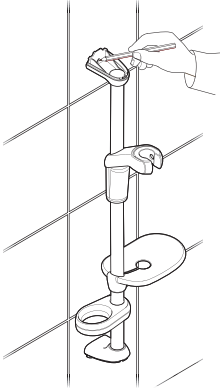

Mark the positions of the slots on both top and bottom Supports.

6.

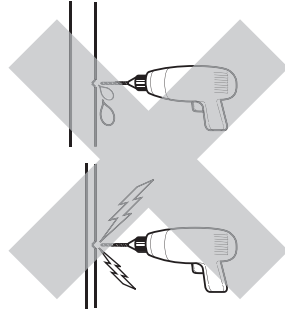

Caution! Do not drill into buried cables or pipes.

7.

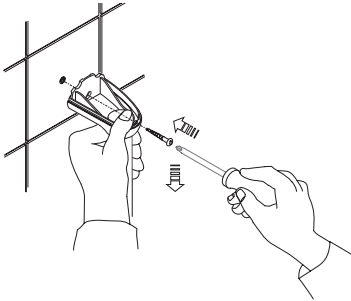

First fix bottom Slide Bar Support and fully tighten the screw*. Then fix the top Slide Bar Support whilst pressing it down, to keep the whole assembly together.

8.

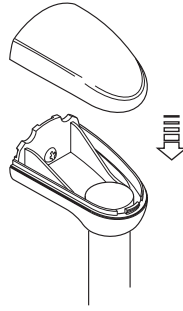

Fit the End Caps to the Slide Bar Supports.

9.

Fit the Hose to both the Handset and the Shower Outlet, remembering to pass it through the Hose Retaining Ring. **Do not** overtighten the Hose connections.

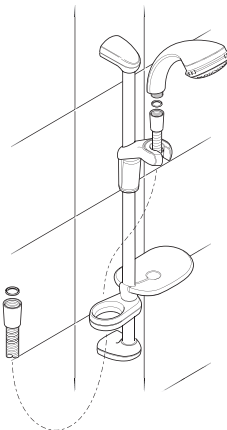

* Alternative fixings for some wall structures are not supplied.

COMMISSIONING

If you are unsure how an electric shower works, please read through the section **“User Instructions”** before continuing.



Electrical supply is turned off at the mains.

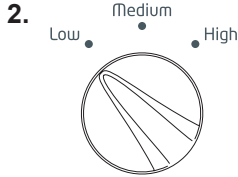

Set control to LOW.

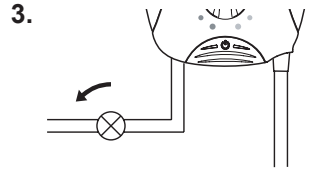

Turn water supply fully on.



Check for water leaks.

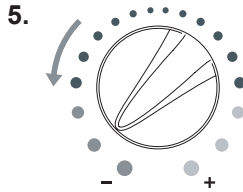

Turn control to full cold.

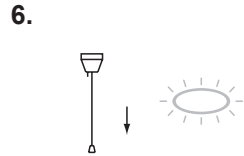

Switch on electrical supply.

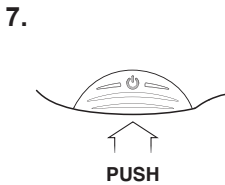

Push START button.

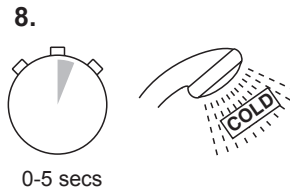

Water will be flowing at a cool temperature.

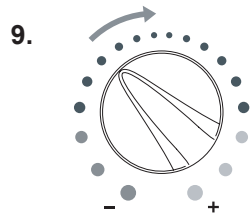

Turn control slowly. Temperature remains cool and flow is reduced.

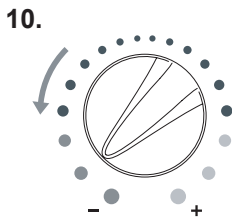

Turn control to full cold.

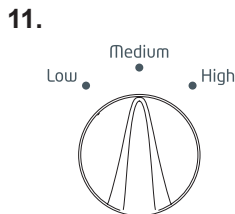

Set control to MEDIUM.

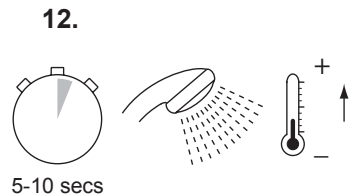

The temperature will rise slightly.

13.

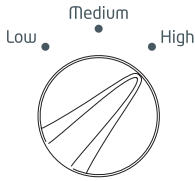

Set control to HIGH.

14.



The temperature will rise further.

15.

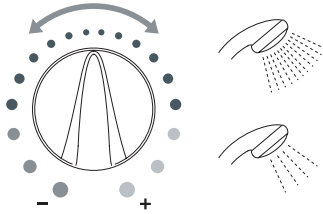

Adjust temperatures as required.
Flow rate will adjust automatically.

16.

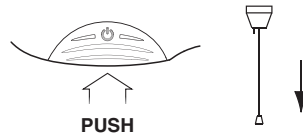

Press STOP and isolate power.

17.



Residual water may drain over a few minutes.

Note! A slight “hissing” sound may be heard from the appliance during operation. High mains water pressure and high shower temperature will affect the tone. This is quite normal in use.

USER INSTRUCTIONS

How Your Electric Shower Works

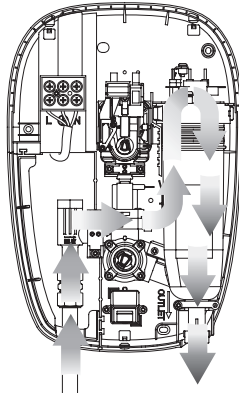

Hot water is produced by passing cold water through a heating tank.

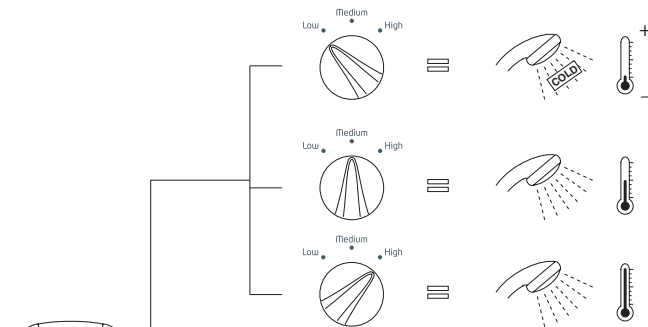

The shower has three heater settings.

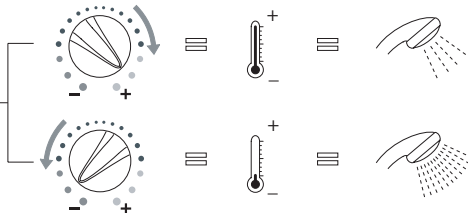

The warmer the shower, the lower the flow rate and vice versa.

The Effect of Seasonal Changes

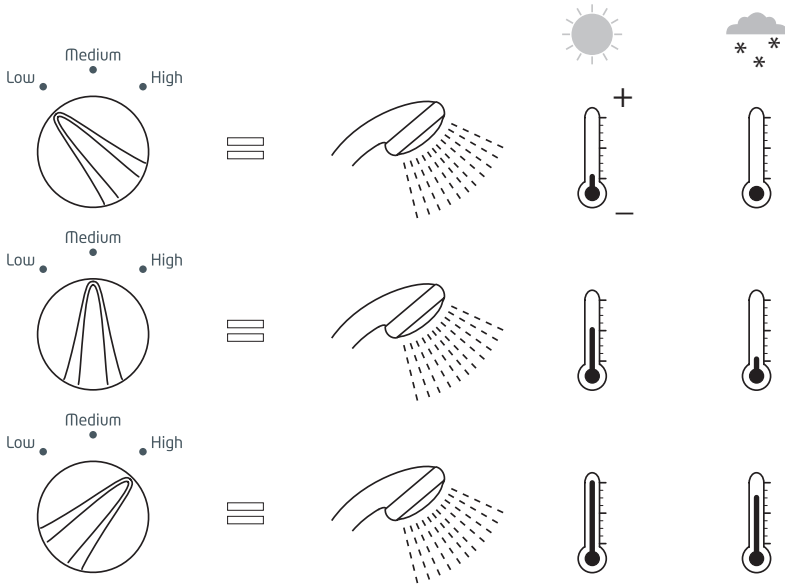

For a cold shower select Low.

For a summer warm shower select Medium.

For a winter warm shower select High.

During extremes of mains water supply temperature, adjust heater setting to obtain a better showering temperature.

The Effect of Other Water Devices

Example of how shower temperature stabilizes due to sudden pressure changes.

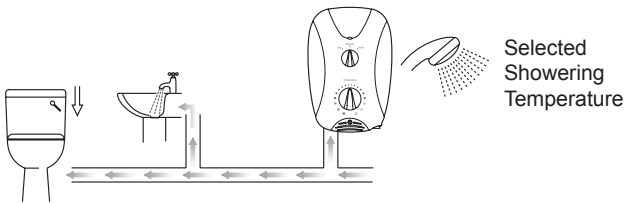

+

Showering temperature will stabilize to within 6°C band if other outlets are opened whilst showering, providing the minimum pressure does not fall below 70 kPa (0.7 bar).

-

Water inlet pressure fluctuations due to other draw offs (e.g. flushing toilet) will cause the showering temperature to increase.

Using Your Shower

Read the section “Important Safety Information” first.

1.

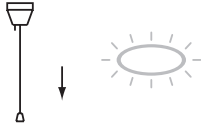

Switch on electrical supply.

2.

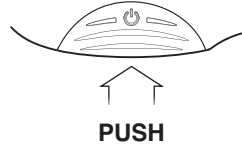

Press START button.

3.

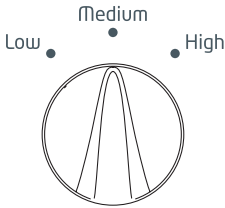

Set to desired position.

4.

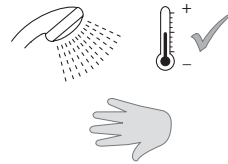

Check water temperature before entering shower.

5.

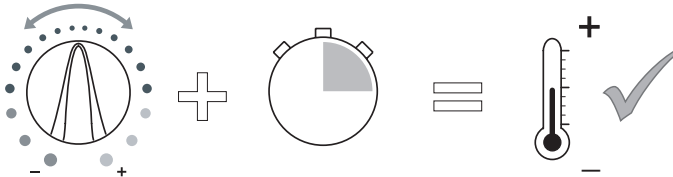

Allow 10-15 seconds for any temperature adjustments to reach the handset.

6.

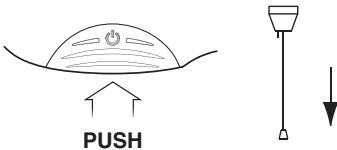

Press STOP button and the shower will shut down.

7.



A small amount of water may continue to drain over a few minutes.

Changing the Spray Setting

The handset has three different spray settings (Start, Soothe and Force).

1.

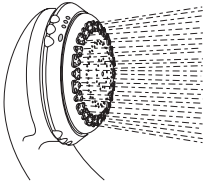

Start

Turn the Spray Plate anticlockwise until it “clicks”. Water will flow from the outer set of holes.

2.

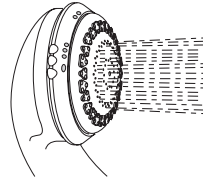

Soothe

Turn the Spray Plate anticlockwise until it “clicks”. Water will flow from the large diameter holes.

3.

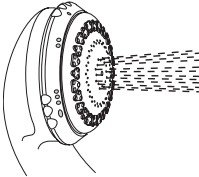

Force

Turn the Spray Plate anticlockwise until it “clicks”. Water will flow from the inner set of holes.

Adjusting the Clamp Bracket

1.

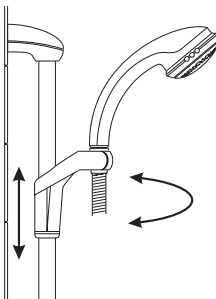

Depress the release button and slide the Clamp Bracket assembly to the required position.

2.

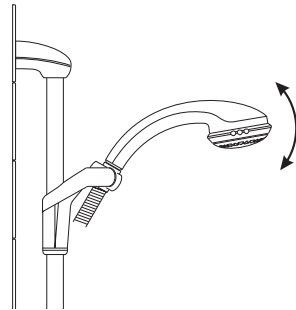

Move the Handset to the required angle.

FAULT DIAGNOSIS

The trouble shooting information table below gives details on probable causes and remedies should difficulties be encountered whilst the shower is in operation.

Warning! There are no user serviceable components beneath the cover of the appliance. **Only a competent tradesperson should remove the front cover!**

Symptom	Power Light	Heater Setting Low/ Med/ High	Probable Cause	Possible Remedy
Shower is too hot during the summer.	ON	High	Incoming water is warmer in the summer, so the shower heater setting is too high.	Turn heater control to medium and adjust temperature control until the desired temperature is achieved.
Shower is too hot.	ON	Med/ High	Handset blocked.	Remove and clean.
Turning the temperature control does not affect the water temperature.	ON	Med/ High	Handset blocked.	Remove and clean. If fault persists, contact the shower installer.
Water continues to flow when double pole switch is turned off.	OFF	Any	The diaphragm is damaged.	Contact shower installer to replace the flow valve assembly.
No water or very low flow rate.	OFF	Any	The power is off at the double pole switch.	Switch on the power at the double pole switch.
	ON	Any	The incoming water supply stop valves, or the appliance isolating valve, is closed.	Open the stop/isolating valve fully.
	ON	Any	Handset blocked.	Remove and clean. For sprayplate cleaning, refer to the handset manual.
	OFF	Any	The fuse is blown or the MCB/RCD has been tripped, indicating a possible electrical fault.	Renew the fuse or reset the MCB/RCD. If the fault persists, contact the shower installer.

Symptom	Power Light	Heater Setting Low/ Med/ High	Probable Cause	Possible Remedy
No hot water from shower, with the controls in any position.	ON	Med/ High	Other water outlets are being used during showering, causing the water pressure to drop below the minimum requirement.	Make sure the other water outlets, such as a washing machine or dishwasher, are not in use during showering.
	ON	Med/ High	The water pressure is below the minimum required.	Make sure that the incoming water supply isolating valve(s) are completely open. If the fault persists, contact the shower installer.
S h o w e r temperature cycles between hot and cold.	ON	Med/ High	The temperature is set too high. This is causing the thermal switch to turn off the heating element to reduce the water temperature.	Turn the temperature control anticlockwise to reduce the water temperature.
	ON	Med/ High	The temperature is set too high. This is causing the thermal switch to turn off the heating element to reduce the water temperature.	Turn the temperature control anticlockwise to reduce the water temperature. Do not tamper with the thermal switch.

All the following remedies must be performed by a competent tradesperson!

No hot water from the shower, with controls in any position.	ON	Med/ High	Insufficient mains water pressure.	Contact local water company.
	ON	Med/ High	Failure of the pressure switch, microswitch or thermal switch.	Check the continuity of the switches, using a suitable continuity measuring device. Replace the switches as necessary.
	ON	Med/ High	I n t e r n a l w i r i n g connection failed.	Check the integrity of the internal wiring.

(continued)....

Symptom	Power Light	Heater Setting Low/ Med/ High	Probable Cause	Possible Remedy
	ON	Med/ High	One of the heater tank elements has failed.	Replace the heater tank.
	ON	Med/ High	Switch assembly diaphragm fault. Water dripping from the unit.	Replace the switch assembly.
Turning the temperature control does not affect the water temperature.	ON	Med/ High	The Flow Regulator is faulty.	Replace the flow regulator.
	ON	Med/ High	The Handset is blocked.	Remove and clean. If fault persists, contact Customer Services.
No water, or very low flow rate.	ON	Any	Handset blocked.	Remove and clean.
	ON	Any	The incoming water supply stop valves, or the appliance isolating valve, is closed.	Open the stop/isolating valve fully.
	ON	Any	Insufficient mains water pressure.	Check the integrity of the internal wiring.
	ON	Any	The heater tank is excessively scaled.	Replace the heater tank.
	ON	Any	The pilot valve is faulty.	Replace.
	ON	Any	Inlet filter blocked.	Clean or renew. See "Maintenance" section.
	OFF	Any	The power is off at the double pole switch.	Switch on the power at the double pole switch.
	OFF	Any	The fuse is blown or the MCB/RCD has been tripped, indicating a possible electrical fault. For example, heater tank element failure.	Renew the fuse or reset the MCB/RCD. Replace the heater tank.

Symptom	Power Light	Heater Setting Low/ Med/ High	Probable Cause	Possible Remedy
Water leaks from the bottom of the case near the outlet. There is no flow from the outlet.	ON	Any	The pressure relief valve in the heater tank has been triggered (this works to reduce the damage to the appliance if the outlet is blocked or the unit is frozen. When the relief valve operates, a small rubber ball is ejected.	Resolve the blocked outlet, and replace the tank assembly.
The water cannot be turned off.	OFF	Any	The Pilot Valve is faulty.	Replace.
	OFF	Any	The diaphragm is damaged.	Replace the flow Valve assembly.
	OFF	Any	The supply pressure is below the minimum requirement.	Contact local water company. Check the static water pressure. Note! The static pressure may fall below minimum requirement when other appliances are drawing water. For example, a washing machine or garden hose.

MAINTENANCE

Handset - Cleaning



Clean with mild washing up detergent or soap solution. Wipe dry with soft cloth.



Poor shower performance can be avoided by cleaning the spray head. Use thumb or soft cloth to wipe rubber nozzles. The handset must also be descaled regularly.

Inlet Filter - Cleaning/Renewing

Read the section “Important Safety Information” first.

1.



Electrical supply is turned off at the mains.

2.

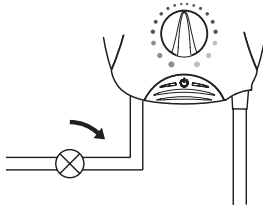

Turn water supply fully off.

3.

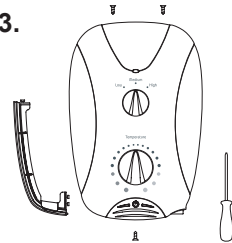

Remove three screws, Cover and Service Tunnel.

4.

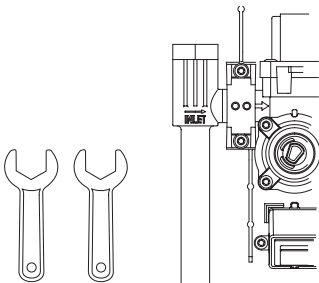

5.

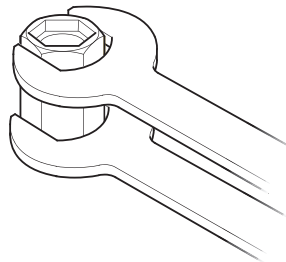

Hold a wrench across the flats of the plastic connector. Unscrew the Filter using another wrench as shown. Clean or renew the Filter as necessary. Refit in reverse order, making sure the Filter is screwed fully home.

Do not overtighten. Make sure plumbing connections are sealed before restoring electricity supply.

DIMENSIONS

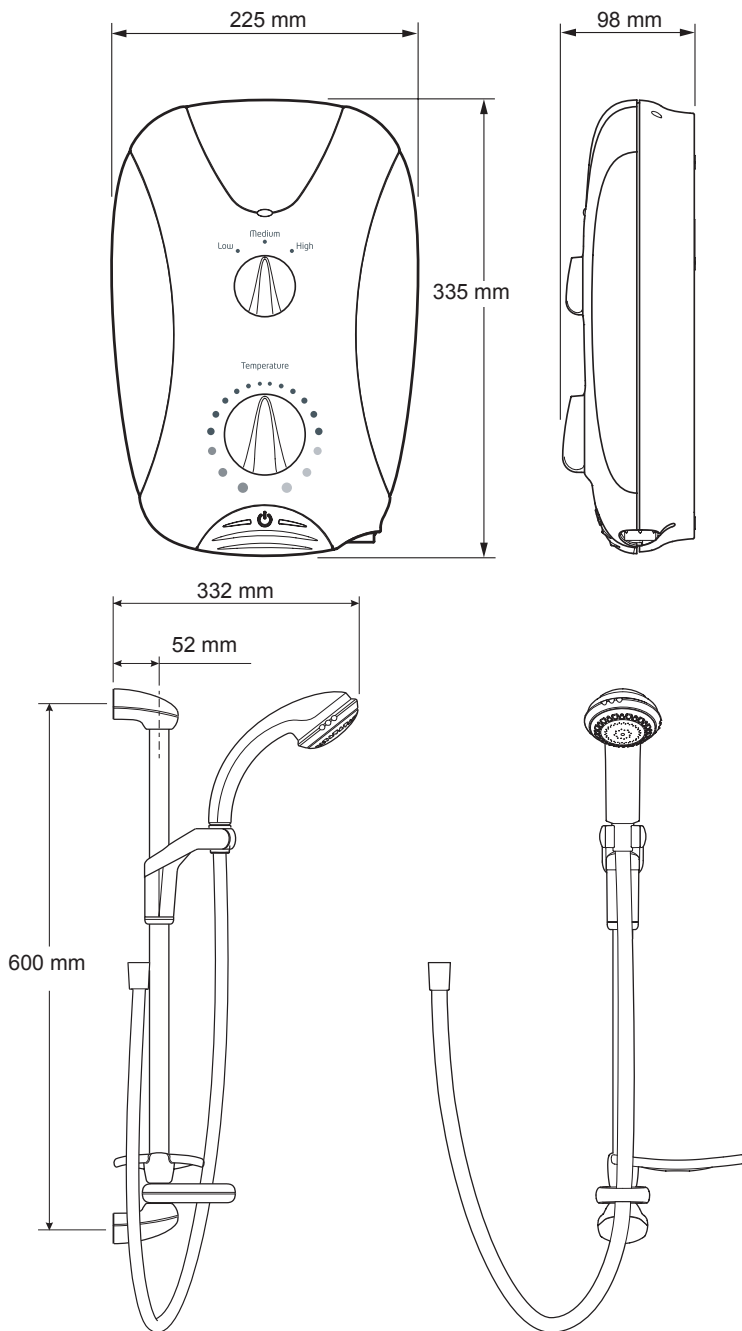

WIRING DIAGRAM

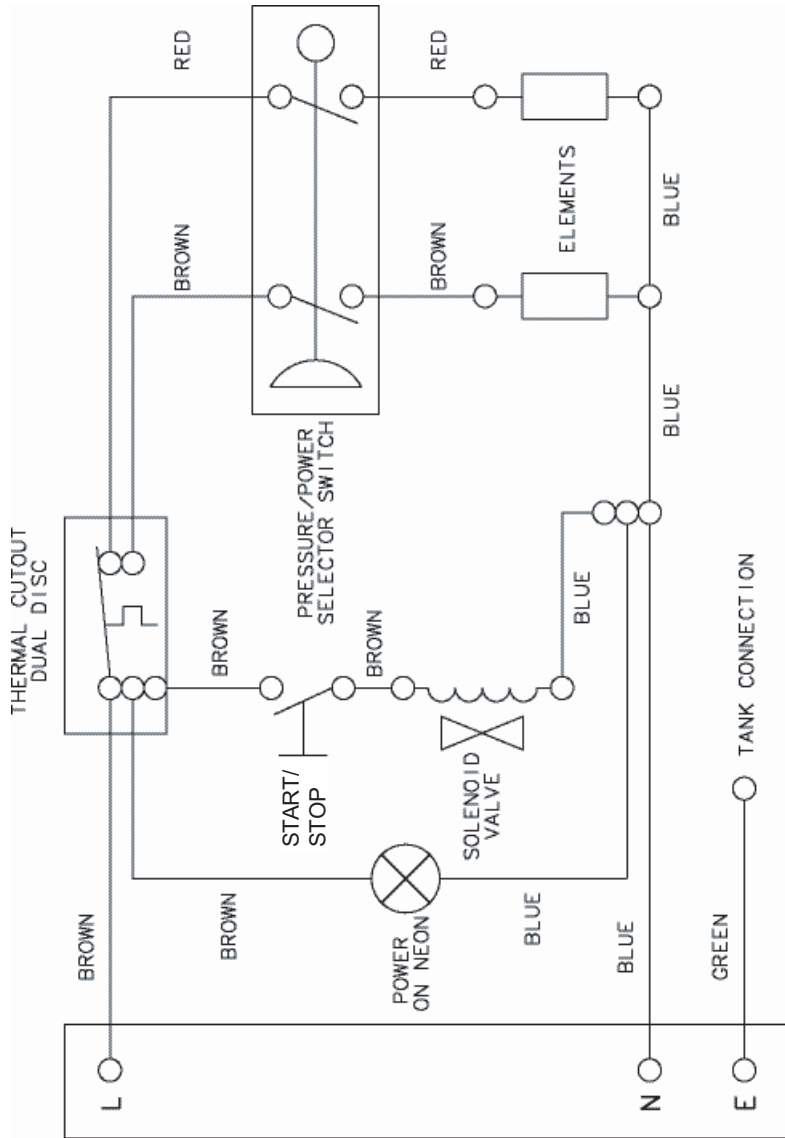

Internal Wiring Diagram

SPARE PARTS

Mira Play

406.27	Inlet filter (with 'O' Seal fitted)
416.38	Inlet Clamp Bracket
439.75	Inlet Connector Assembly
439.76	Clamp Bracket - components identified "A"
439.77	Flow Regulator Assembly 8.5kW
439.88	Seal Pack - components identified "B"
439.89	Screw Pack - components identified "C"
439.90	Thermal Switch
1539.339	Switch Assembly
1539.340	Neon Assembly (not shown)
1539.341	Cover Assembly - White/White Panel
1539.342	Cover Assembly - Satin/Chrome Panel
1539.343	Service Tunnel - White
1539.344	Service Tunnel - Satin
1539.349	Terminal Block Assembly
1539.350	Flow Regulator Assembly
1539.352	Start/Stop Switch Assembly
1539.355	Cover Assembly - White/Chrome Panel
1798.054	Heater Tank 8.5 kW
1798.055	Heater Tank 9.5 kW
1798.056	Heater Tank 10.8 kW

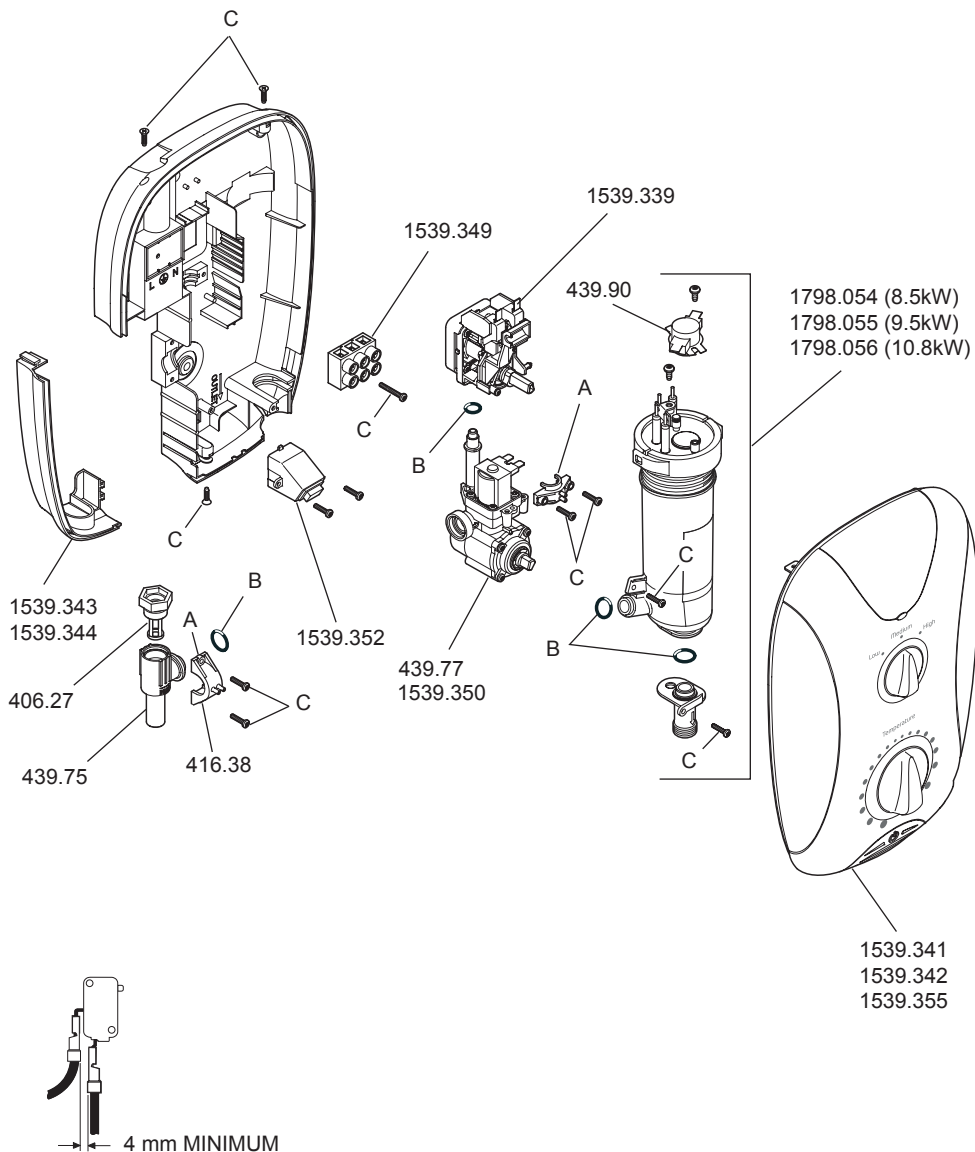

Important Note! Push-fit connectors must be assembled back to back onto terminals of micro-switches.

A minimum air gap of 4 mm must be maintained between the connectors after assembly.

Mira Response Shower Fittings

150.58	Hose - chrome
411.05	Adjuster Ring - white
411.23	Clamp Bracket Assembly - white
411.30	Slide Bar Support Assembly - white
411.37	Service Pack 'O' Seals - components identified 'A'
411.53	Slide Bar - stainless steel
411.58	Hose Retaining Ring - white
411.91	Soap Dish Pack - white
411.92	Adjustable Handset - white
411.94	Screw Pack
411.96	Spray Plate Assembly - Low capacity
413.22	Adjuster Ring - satin chrome
413.24	Clamp Bracket Assembly - chrome
413.30	Slide Bar Support Assembly - chrome
413.33	Hose Retaining Ring - chrome
413.34	Soap Dish Pack - chrome
413.58	Adjustable Handset - chrome
632.73	Hose Washer

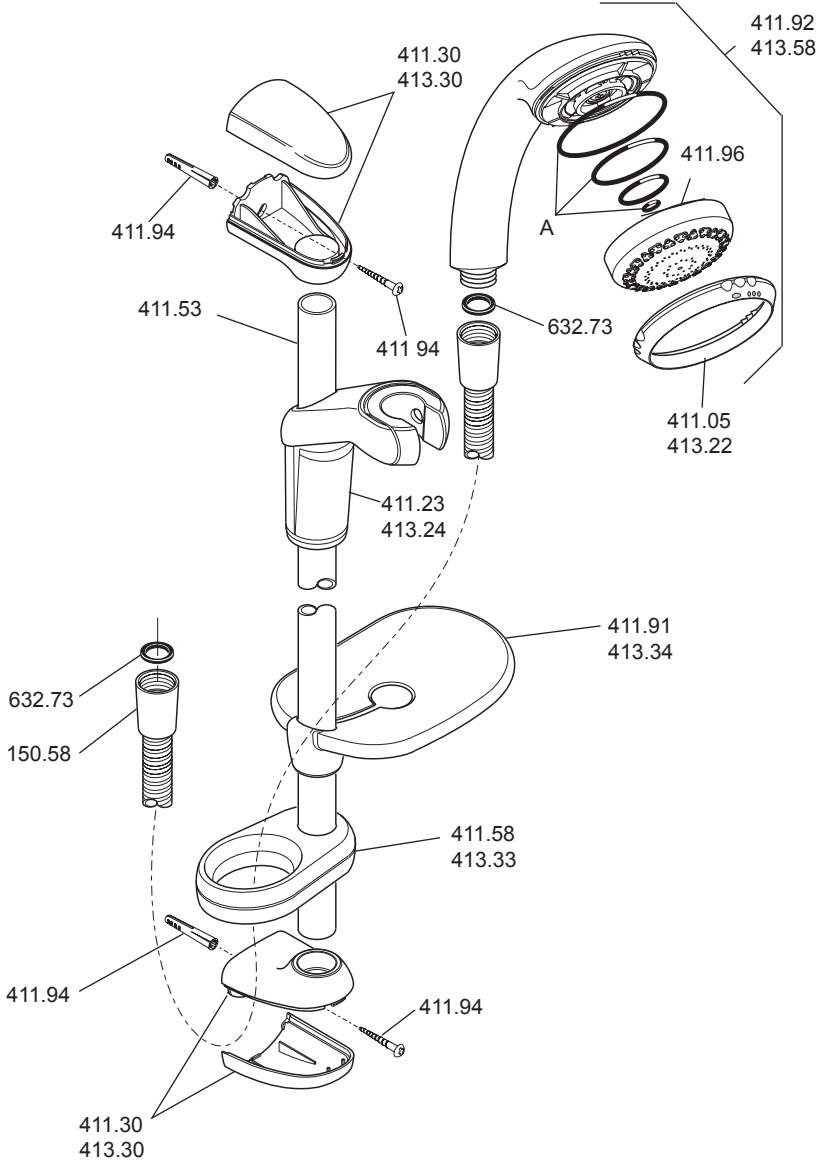

ACCESSORIES

Genuine Mira accessories can be purchased direct from Customers Services (our contact details can be found on the back cover of this guide) or from approved stockists or merchants.

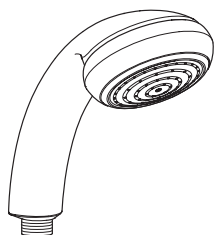

Everclear Showerhead
White - 2.1616.030
Chrome - 2.1616.031

Mira's new Everclear range has been specially designed for hard water areas and reduces the risk of lime scale build up.

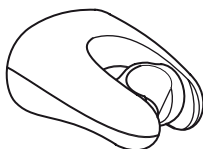

Showerhead Holder
White - 1.1540.270
Chrome - 1.1540.271

An alternative to the traditional slide bar. Often a useful addition when positioned for the smaller members of the family.

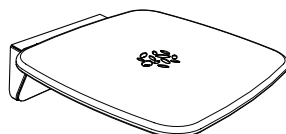

Premium Shower Seat
White/Chrome - 2.1731.001
Grey/Chrome - 2.1731.002

Stylish, slim-line and robust shower seat for use in or outside of the shower area. Folds up when not in use. Maximum User Weight - 150 kg (23.5 stone) **Note!** Must be installed onto a solid wall.

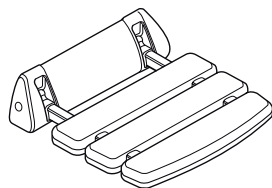

Shower Seat
White - 2.1536.128
White/Chrome - 2.1536.129

For use in or out of the showering area. Folds up when not in use. Maximum User Weight - 127 kg (20 stone) **Note!** Must be installed onto a solid wall.



Mira Standard Grab Bars
300 mm - 2.1605.070
450 mm - 2.1605.071
600 mm - 2.1605.072

Premium grade, highly polished, stainless steel grab bars. **Note!** Must be installed onto a solid wall.

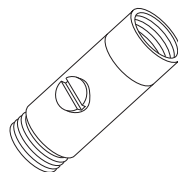

Outlet Double Check Valve (DCV-H)
Chrome - 1.0.110.55.1

DCV-H: An outlet double check valve, designed to prevent the backflow or backsiphonage of potentially contaminated water, through shower controls which are fitted with a flexible hose as part of the outlet shower fitting.

NOTES

NOTES

CUSTOMER SERVICE

Guarantee

Your product has the benefit of our manufacturer's guarantee which starts from the date of purchase.

To activate this guarantee, please return your completed registration card, visit our website or free phone 0800 0731248 within 30 days of purchase (UK only).

Within the guarantee period we will resolve defects in materials or workmanship, free of charge, by repairing or replacing parts or product as we may choose.

This guarantee is in addition to your statutory rights and is subject to the following conditions:

- The guarantee applies solely to the original installation under normal use and to the original purchaser only. The product must be installed and maintained in accordance with the instructions given in this user guide.
- Servicing must only be undertaken by us or our appointed representative. **Note!** if a service visit is required the product must be fully installed and connected to services.
- Repair under this guarantee does not extend the original expiry date. The guarantee on any replacement parts or product ends at the original expiry date.
- For shower fittings or consumable items we reserve the right to supply replacement parts only.

The guarantee does not cover:

- Call out charges for non product faults (such as damage or performance issues arising from incorrect installation, improper use, inappropriate cleaning, lack of maintenance, build up of limescale, frost damage, corrosion, system debris or blocked filters) or where no fault has been found with the product.
- Water or electrical supply, waste and isolation issues.
- Compensation for loss of use of the product or consequential loss of any kind.
- Damage or defects caused if the product is repaired or modified by persons not authorised by us or our appointed representative.
- Routine maintenance or replacement parts to comply with the requirements of the TMV 2 or TMV 3 healthcare schemes.
- Accidental or wilful damage.
- Products purchased ex-showroom display.

What to do if something goes wrong

If your product does not work correctly refer to this manual for fault diagnosis and check that it is installed and commissioned in accordance with our instructions.

If this does not resolve the issue, contact us for help and advice.

Extended Guarantees

A selection of protection plans are available that enable you to cover repair bills (excludes Eire). Ring 01922 471763 for more details.



Helpdesk Service - Ring our Customer Services Team for product advice, to purchase spare parts or accessories or to set up service visit. You can contact us via phone or e-mail, details below. Please provide your model name, power rating (if applicable) and date of purchase.



Mira Showers Website (www.mirashowers.co.uk)

Visit our website to register your guarantee, download user guides, diagnose faults, purchase our full range of accessories and popular spares, or request a service visit.



Spares and Accessories - We hold the largest stocks of genuine Mira spares and accessories. Contact us for a price or visit our website to purchase items from our accessory range and popular spares.



Service/Repairs - No one knows our products better than our nationwide team of Service Technicians. We can carry out service or repair work to your product both during and after the guarantee period. Ask about our fixed price service repairs.

To Contact Us: UK



0844 571 5000



Fax: 01242 282595



E-mail: Visit www.mirashowers.co.uk/contactus



Mira Customer Services Dept, Cromwell Road, Cheltenham, Gloucestershire, GL52 5EP

To Contact Us: Eire Only



01 531 9337



E-mail: CustomerServiceEire@mirashowers.com

Mira is a registered trade mark of Kohler Mira Limited.

The company reserves the right to alter product specifications without notice.



mira
SHOWERS