

ACRYLIC



Model AC4844

Model AC4844
(Left-hand Seat)

Model AC4845
(Right-hand Seat)

Width: 50 1/2" (1283 mm)

Depth: 36 1/2" (927 mm)

Height: 90" (2286 mm)

Shipping Weight: 185 lbs. (83.9 Kg)

Materials: Manufactured from a one-piece acrylic sheet, reinforced with fibreglass.

The Avocet shower module includes a large acrylic grip rail, contoured seats on either side and is 90" in height. With a centre drain, left- or right-hand plumbing can be applied.

Standard Features:

- Easy to clean high gloss surface
- Chip and mar resistant
- Moulded-in floor pattern
- Upper and lower toiletry shelves
- Clear acrylic grip rail
- 4.5" high threshold
- Extended height of 90"
- Accepts right- or left-hand plumbing
- Integral seat

Options:

- Light kit

Colours:

- Standard: White, Almond (Bone) or Biscuit

Other Configurations:

- 3-piece knockdown (KD)
- Seat-less (AC4846)

All products manufactured by Hytec are covered by a comprehensive five-year limited warranty from the date of sale to the original owner. See the Hytec Bathing Fixtures List Price Book for further details.

Hytec Plumbing Products

(Division of Kohler Canada Co.)

4150 Spallumcheen Dr, Armstrong BC V0E 1B6

Ph. (800) 871-8311 (250) 546-3196 Fax (250) 546-3170



ACRYLIC

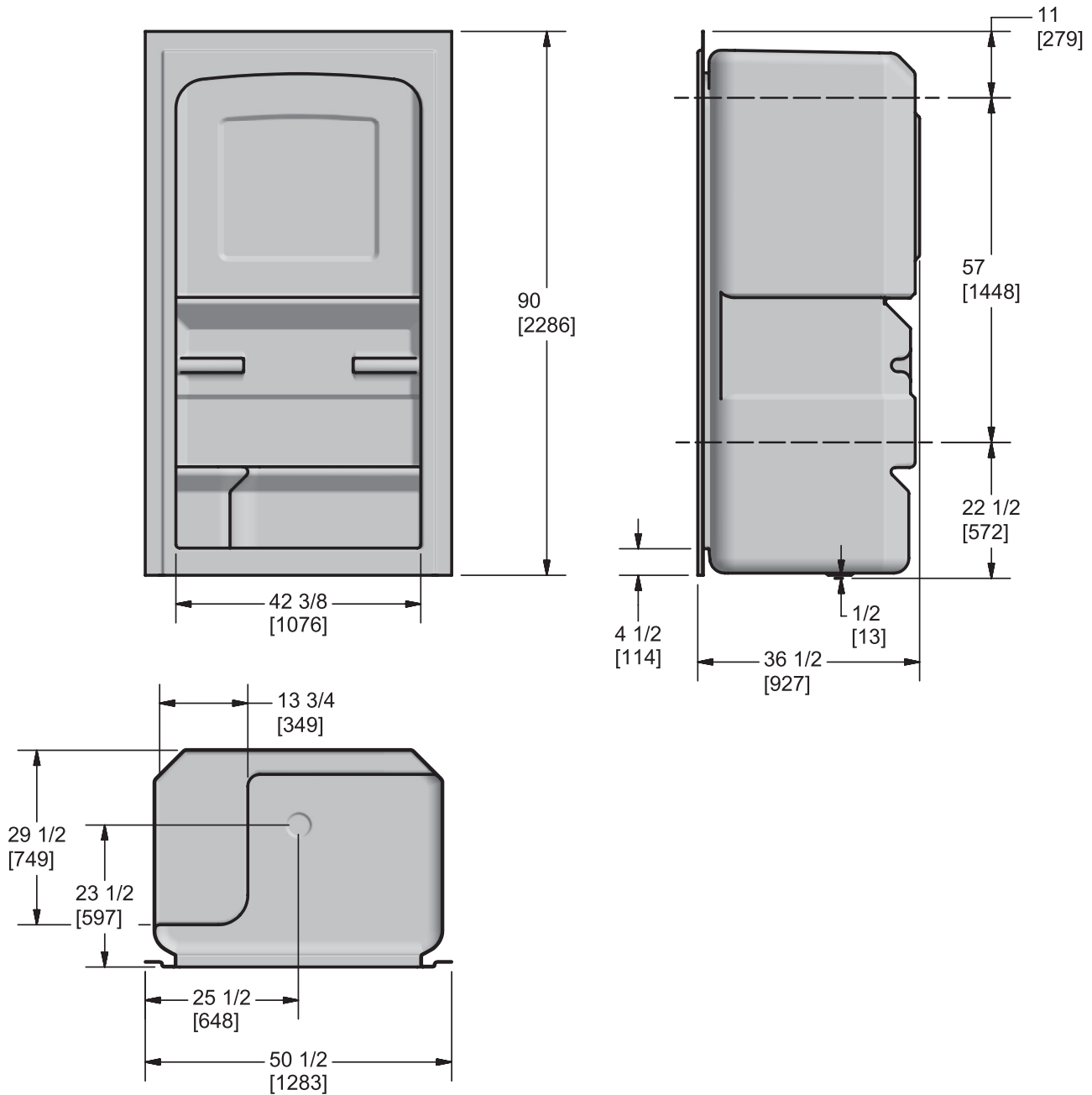

Measurement tolerances $\pm 1/4"$ (6.3 mm)

All bathing fixtures comply with the applicable Canadian Standards.

For installation procedures, please refer to instructions included with each unit.

This sheet approximately describes products and equipment manufactured or supplied by Hytec Plumbing Products. Because of ongoing efforts to improve both design and quality, products and equipment actually furnished may differ without prior notice.



Hytec Plumbing Products

(Division of Kohler Canada Co.)

4150 Spallumcheen Dr, Armstrong BC V0E 1B6

Ph. (800) 871-8311 (250) 546-3196 Fax (250) 546-3170