

IMPORTANT – LEAVE THESE INSTRUCTIONS WITH THIS UNIT



GELCOAT TUBS WITH INTEGRAL APRON
INSTALLATION INSTRUCTIONS & FRAMING
DIMENSIONS

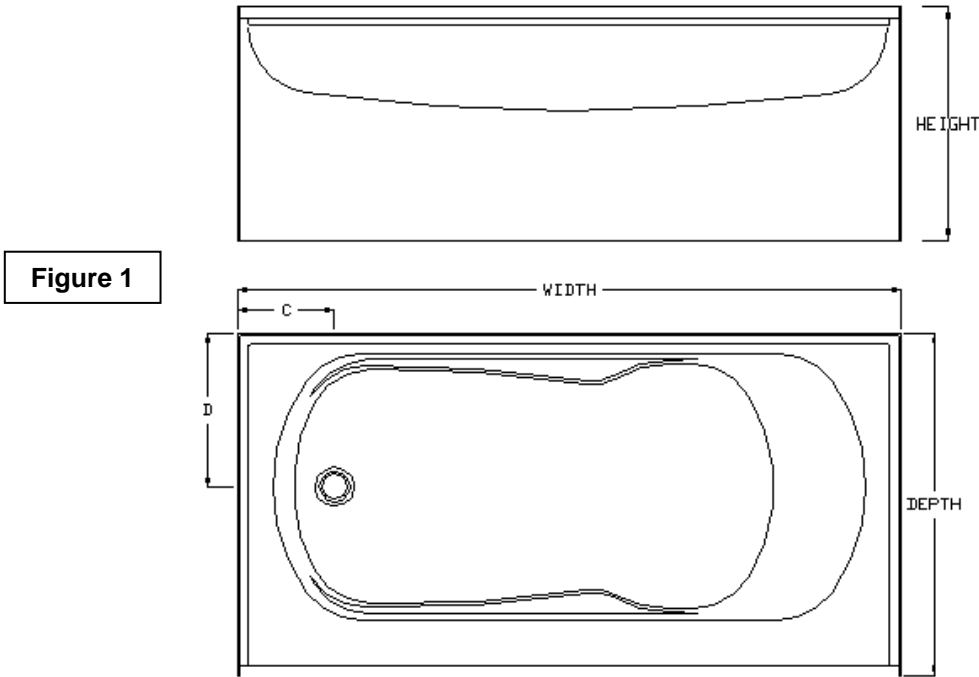

Figure 1

MODEL	PRODUCT	HEIGHT	WIDTH	DEPTH	DRAIN LOCATION	
					C	D
3060/3061	60" Tub RH/LH	21 7/8" 556mm	59 7/8" 1521mm	31" 787mm	9 1/4"	13 7/8"
					235mm	352mm
3832/3833	60" Tub RH/LH	22 1/4" 565mm	60" 1524mm	31 1/4" 794mm	7 1/2"	14"
					191mm	356mm
3930/3931	60" Tub RH/LH	16" 406mm	60" 1524mm	31 1/4" 794mm	7 1/2"	14"
					191mm	356mm

PLANNING

1. Make sure that you will be able to get the tub through the doorway before closing in the room.
2. Floor support under bath must provide for a minimum of 50 lb/square foot (244 kg/square meter) loading.
3. In locations where plumbing is adjacent to a masonry wall, provision must be made for access to connections.
4. When a fire-rated wall is specified, the finished fire-rated wallboards should be in place prior to installation of the unit (NOTE: In this case, allowance must be made for the thickness of the wall board when constructing the framing pocket.)
5. Support:
 - 3832/33 and 3060/61 come standard with adjustable leveling feet that will eliminate the need for additional bottom support in all types of wood or steel stud construction.
 - 3930/31 (no adjustable feet), require that the tubs are supported from below using grout or mortar mix. Please see the "Application of Grout or Mortar" section for additional information.

INSTALLATION

WARNING: Make sure a watertight seal exists on all drain connections (flange, gasket and thread).

1. Square and plumb a framed recess pocket to the outside dimensions of the unit, as shown in the diagram.
2. Locate correct position for drain and trap and cut out floor, leaving clearance for final positioning and hook up.
3. Slide unit into position and check that framing pocket is correct.
4. Remove from pocket and install waste and overflow.
5. Replace unit in pocket, plumb and level. When leveling the tub, please make sure the adjustable feet (3832/33 and 3060/61), are in full contact with the bathroom floor. For the 3930/31, please see the "application of grout or mortar" section.

IMPORTANT NOTE: For proper drainage, the maximum allowed tolerance for leveling is 1/8" over the length and width of the unit.



6. The leveled and supported tub (adjustable feet or grout/mortar), should also have the **apron in contact with the floor throughout its length**. In case the floor is not leveled and part of the apron is not touching the floor, it's a must to shim the apron and fill the gap with a structural material like wood or plastic. The distance between shims should not exceed 6" and the max. gap to shim should not exceed 1/4".
7. Secure nailing flange to studs with large head galvanized nails or flat head screws, 8" (203mm) or 16" (406mm) on centre. (NOTE: Heads should not protrude too much, or drywall installation may be affected.)

Application of Grout or Mortar.

- On the tub floor, measure the distance between one of the corners of the bathing well and the center. The middle point of this distance will be the location of the grout/mortar mix.
- Repeat and mark the spot for the other 3 corners of the bathing well.
- Mix the material with water in 4 Ziploc sandwich bags. Make sure that you have enough grout to support the tub on each spot (close the gap between the floor and the unit). Please see the instructions provided by the supplier to find the recommended mix ratios.
- Place the 4 Ziploc bags with mortar mix (you can keep it inside the bags), and re-check the level at both ends and along the back wall.
- Let the mortar/grout cure.

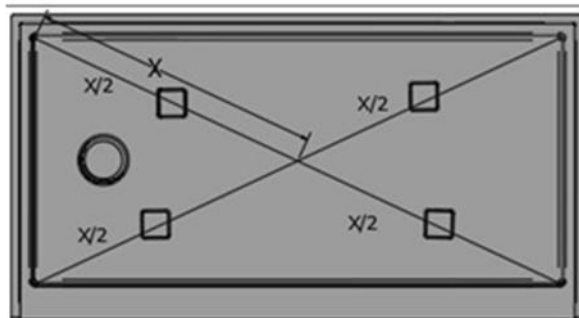

DRYWALLING

After the tub is installed, proceed with installation of drywall.

Our recommended drywall system, if tile is being used as the finish surface, is to butt the bottom of the drywall up to the top of the sealing flange. The tile can then project over the edge of the drywall, down to the horizontal ledge, 1" above the surface of the tub. (See Figure 2)

Alternatively, if the drywall is to be painted as the finish surface, the drywall can be butted to the nailing flange, or overlap the nailing flange, and be brought down to 1/4" above the tile ledge. In either case, a bead of sealant such as silicone should be run along the bottom edge and gap filler. (See Figure 3)

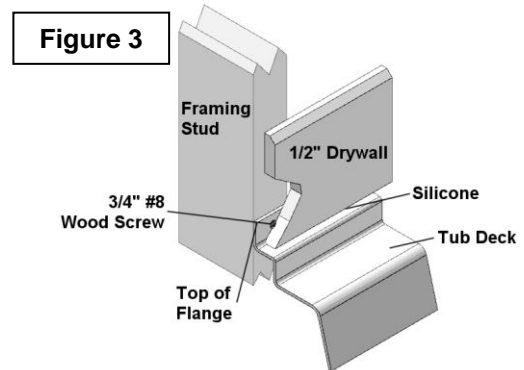
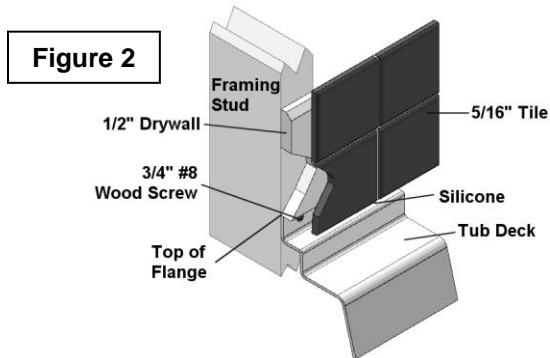

USER CARE & MAINTENANCE

The following hints on care and maintenance are offered to assist you in keeping your tub or shower in "as new" condition.

Normal Care:

A quick sponge-down with warm water and a liquid detergent such as Mr. Clean, Fantastic, or Lysol Tub and Tile Cleaner will take care of most cleaning needs. In areas where the water is hard, more frequent cleaning will be necessary to avoid a build up on the surface.

We recommend that a good quality car or boat wax be applied occasionally – this will preserve the gloss and will make cleaning easier.

Stains:

For stubborn stains, start with a liquid detergent; if this does not work, try a mild powder detergent such as Spic and Span, which also works well for removing heavy soap film. Cleaning pads made of nylon, saran or polyethylene and containing no abrasives may be used. **Do not use abrasive scouring powders or metal scouring pads – they can permanently damage the finish.**

A mild abrasive action can be accomplished with an automobile type of rubbing compound – there are several types available, both coarse and fine. The fine ones take a little longer to remove a stain, but they do not dull the surface as much.

Dull Areas:

Should your stain removal result in a dull area, the shine can be restored with an automobile cleaner wax, such as Turtle Wax.

Paint Splashes:

A quick wipe with mineral spirits, turpentine or Polyclens and then a wash with water will remove paint. **Do not use paint remover or stripper, as these contain solvents, which could permanently damage the surface.**

Things to Avoid: Sand and grit. Dropped tools.

Damage:

Should your unit suffer accidental damage, it is quite possible that it can be repaired by a qualified repairperson. Consult your plumber, wholesaler or a Hytec Sales Agent.



LIMITED 5 YEAR WARRANTY

All acrylic and gelcoat products manufactured by Hytec are covered by a 5-year warranty from the date of sale to the original owner. This warranty does not cover materials and component parts manufactured by others (such as pumps, jets, pipes, and fittings), which are subject to warranties offered by their original manufacturers. Hytec Plumbing Products warrants to the purchaser of each Hytec product that such product will at time of sale be free from defect in material and workmanship, and that Hytec will at its option repair the original unit or supply an equivalent unit in exchange, such exchange to be F.O.B. at Hytec warehouse. Hytec shall not be responsible for shipping, handling, or installation damage; or any expense of removal, transportation or installation of any original or exchange unit. Under no circumstances will Hytec Plumbing Products assume liability for consequential damages or labour charges resulting therefrom.

This warranty is non-transferable and shall be voided if the unit is removed from its place of initial installation or is not installed in accordance with the manufacturer's instructions. Further, this warranty does not apply if the unit has been subjected to accident, abuse, misuse, damage caused by flood, fire or act of God, or if the unit or the plumbing fixtures used in connection with it are not installed in compliance with local codes and ordinances. Any modifications or alterations to a unit, without prior authorization from Hytec Plumbing Products, or the installation of therapy jets by anyone other than Hytec Plumbing Products, will void all warranties. This includes the installation of steam generators.

HYTEC'S LIMITED WARRANTY OBLIGATIONS ARE EXPRESSLY LIMITED TO THOSE SET FORTH HEREIN, AND ARE IN LIEU OF ALL OTHER WARRANTIES, EXPRESSED OR IMPLIED. THE LIABILITY OF HYTEC TO THE BUYER WITH RESPECT TO THE SALE OF A UNIT SHALL BE LIMITED TO REPAIR OR REPLACEMENT AS PROVIDED HEREIN TO A MAXIMUM OF THE PURCHASE PRICE OF THE RELEVANT UNIT AND DOES NOT INCLUDE ANY COST OF REMOVAL OR REINSTALLATION OR CONSEQUENTIAL DAMAGES OF ANY KIND.

To obtain warranty service, contact Hytec Customer Service at **(800) 871-8311** or **(250) 546-3067**, or email **hytec.customer.service@kohler.com**. Please have ready all pertinent information regarding your claim, including a complete description of the problem, the product, model number, serial number and a copy of your original invoice. If the serial number is not available, please provide a digital photo of the unit.

Authorized Service Representatives for Hytec have been thoroughly trained to perform both in and out of warranty repairs to Hytec products. Through this training, they are familiar with the Hytec Warranty Policy. If in the opinion of the Authorized Service Representative, the service required is not within the scope of the Hytec Warranty Policy, they will advise you before beginning the work. Should this occur, payment of all invoices related to the service is the responsibility of the consumer. If the problem can be attributed to incorrect installation, please contact your installing contractor. Should there be a difference of opinion pertaining to warranty coverage between the Authorized Service Representative and the consumer; clarification will be provided by Hytec Customer Service.

HYTEC PLUMBING PRODUCTS
(Division of Kohler Canada Co.)
4150 Spallumcheen Drive
Armstrong, BC, V0E 1B6
Phone (250) 546-3067 • Fax (250) 546-3170

Please visit our website <http://www.hytec.ca> to find your local representative contact information.