

IMPORTANT – LEAVE THE INSTRUCTIONS WITH THIS UNIT



ACRYLIC BATHTUBS **WITH INTEGRAL APRONS** INSTALLATION INSTRUCTIONS

TUBS WITH EXTENDED FLANGES

PLANNING

1. Make sure that you will be able to get the tub through the doorway before closing in the room.
2. Floor support under bath must provide for a minimum of 50 lb. /square foot (244 kg/square meter) loading.
3. In locations where plumbing is adjacent to a masonry wall, provision must be made for access to connections.
4. When a fire-rated wall is specified, the finished fire-rated wallboards should be in place prior to installation of the unit (NOTE: In this case, allowance must be made for the thickness of the wall board when constructing the framing pocket.)
5. In wood frame and 20 gauge or thicker ($\geq .0375$ ") "Structural Steel" stud construction Hytec tubs and showers are all designed to rest on their front apron and be supported by the nailing flanges along both sides and back. The flanges are attached by screws to the studs that form the framing pocket.
6. Once satisfied with location, mark and drill clearance holes in the nailing flange for mounting screws, lining up with the centre of all wall studs. (Fig 1 & 2) *NOTE: Failure to drill clearance holes may result in stress cracks in the acrylic finish.*
7. No other support is necessary with the following exceptions: a) The installer prefers to add shims or a reasonably dry grout or mortar mix under the tub bottom. b) The framing pocket is made of steel studs with a thickness of less than 20 gauge ($< .0375$ ") "Structural Steel".
8. In steel stud construction using studs that are of a thickness less than 20 gauge ($< .0375$ ") "Structural Steel" it is a requirement that the tubs and showers are supported from below using shims, grout or mortar mix. (see our web site for suggested support methods or contact us directly for technical support)
9. Some products come standard with adjustable leveling feet that will eliminate the need for additional bottom support in all types of wood or steel stud construction****.

****EXCLUDES -M16, M19, AC4086, AC20460

PRODUCT DIMENSIONS Measurement tolerances $\pm 1/4"$ (6.3mm)

MODEL	LENGTH	DEPTH	HEIGHT	C	D
AC3060 **	60" / 1524mm	30" / 762mm	22 1/2" / 572mm	9 1/4" / 235mm	14 1/4" / 362mm
AC3077	60" / 1524mm	30" / 762mm	24" / 610mm	10 3/8" / 264mm	13 7/8" / 352mm
AC3260	60" / 1524mm	32" / 813mm	22 1/2" / 572mm	9 3/16" / 233mm	15 1/2" / 394mm
AC3266 **	66" / 1676mm	32" / 813mm	22 1/2" / 572mm	9 3/16" / 233mm	15 1/2" / 394mm
AC3272 **	72" / 1829mm	32" / 813mm	22 1/2" / 572mm	9 3/16" / 233mm	15 1/2" / 394mm
AC3495 **	59 3/4" / 1518mm	34" / 862mm	22 3/4" / 578mm	8 3/8" / 213mm	17" / 432mm
AC3616 **	66" / 1676mm	36" / 914mm	23" / 584mm	8 1/4" / 210mm	18" / 457mm
AC3621	60" / 1524mm	32" / 813mm	24" / 610mm	10 3/8" / 264mm	15 7/8" / 403mm
AC3637	60" / 1524mm	32" / 813mm	22 3/8" / 568mm	8 3/4" / 223mm	16" / 406mm
AC3660 **	59 3/4" / 1518mm	35 7/8" / 911mm	23" / 584mm	9 3/8" / 238mm	20 1/2" / 521mm
AC3745	60" / 1524mm	30" / 762mm	22 3/8" / 568mm	8 3/4" / 223mm	14" / 356mm
AC3745-M1	54" / 1372mm	30" / 762mm	22 1/4" / 591mm	5 11/16" / 144mm	16" 1/16" / 408mm
AC3747	66" / 1676mm	32" / 813mm	23 1/4" / 591mm	9 3/4" / 248mm	16" / 406mm
AC3762	66" / 1676mm	30" / 762mm	23 1/4" / 591mm	9 3/4" / 248mm	14" / 356mm
AC3763	72" / 1829mm	30" / 762mm	23 1/4" / 591mm	9 3/4" / 248mm	14" / 356mm
AC3764	66" / 1676mm	30" / 762mm	23 1/4" / 591mm	9 3/4" / 248mm	14" / 356mm
AC3765	66" / 1676mm	32" / 813mm	23 1/4" / 591mm	9 3/4" / 248mm	16" / 406mm
AC3766	72" / 1829mm	30" / 762mm	23 1/4" / 591mm	9 3/4" / 248mm	14" / 356mm
AC3767	72" / 1829mm	32" / 813mm	23 1/4" / 591mm	9 3/4" / 248mm	16" / 406mm
AC3768	72" / 1829mm	32" / 813mm	23 1/4" / 591mm	9 3/4" / 248mm	16" / 406mm
AC3957	66" / 1676mm	32" / 813mm	22 3/8" / 568mm	9 1/2" / 241mm	16" / 406mm
AC4086	66" / 1676mm	32" / 813mm	17 1/4" / 438mm	8" / 203mm	16" / 406mm
AC4154	72" / 1829mm	32" / 813mm	22 1/4" / 591mm	8 3/4" / 223mm	16" / 406mm
AC8571	72" / 1829mm	30" / 762mm	22 1/4" / 591mm	8 3/4" / 223mm	14" / 356mm
AC20460PL/R2	60 1/4" / 1530mm	30 1/8" / 765mm	22 1/2" / 572mm	10 1/16" / 256mm	16" / 406mm
AC20486L/R	60" / 1524mm	30" / 762mm	21 5/8" / 549mm	5" / 127mm	14" / 356mm
AC20487L/R	66" / 1676mm	30" / 762mm	21 5/8" / 549mm	5" / 127mm	14" / 356mm
ACLW20446	59 7/8" / 1521mm	34" / 862mm	22 1/4" / 591mm	8 7/8" / 225mm	16 3/4" / 425mm
ACLW20143	59 3/4" / 1518mm	36" / 914mm	22 1/4" / 591mm	8 3/8" / 213mm	17 3/4" / 451mm
ACLW20462	59 3/4" / 1518mm	34" / 862mm	22 1/4" / 591mm	8 3/8" / 213mm	17 3/4" / 451mm
ACLW3260	59 7/8" / 1521mm	32 1/2" / 826mm	22 1/4" / 591mm	9 3/16" / 233mm	15 1/8" / 384mm

** ACL / ACW Apron Styles Included

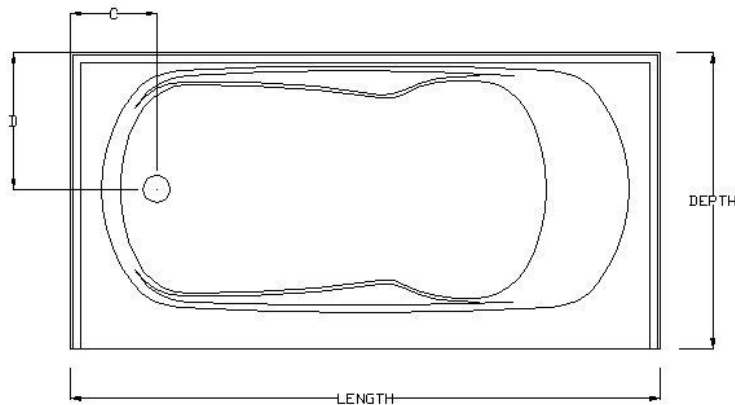

DRYWALLING

After the tub is installed, proceed with installation of drywall. Our recommended drywall system, if tile is being used as the finish surface, is to butt the bottom of the drywall up to the top of the sealing flange. The tile can then project over the edge of the drywall, down to the horizontal ledge 1" above the surface of the tub on double flange models (See Figure 1) or down to the deck on single flange models.

Alternatively, if the drywall is to be painted as the finish surface, the drywall can be butted to the nailing flange, or overlap the nailing flange, and be brought down to ¼" above the tile ledge (or deck on single flange models). In either case, a bead of sealant such as silicone should be run along the bottom edge and used to fill any gaps. (See Figure 2)

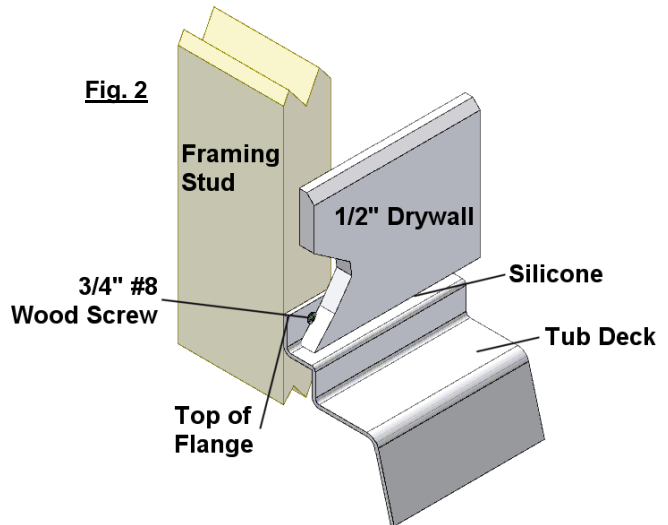
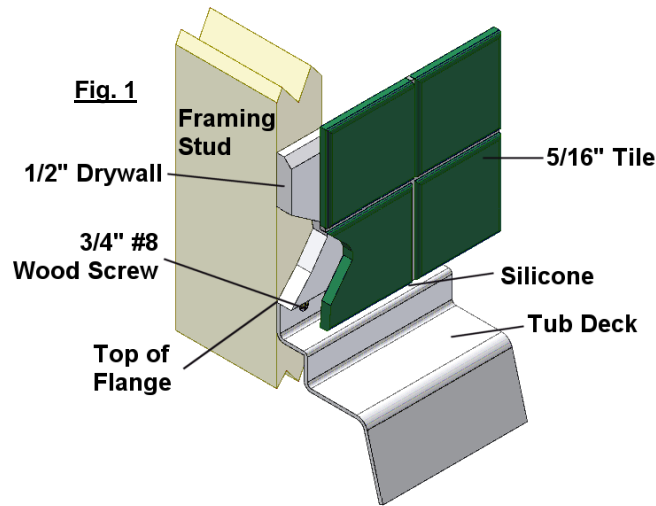

REMOVABLE ACCESS-PANEL MODELS (AL/AR)

On aprons with removable access panels for entry to the pump and wiring from the front of the unit, the access panel can be removed by inserting the blade of a flat screwdriver, or a dull kitchen knife, under any corner of the panel. (Take care not to scratch the exposed acrylic surfaces.) Gently pry the panel off, working around the perimeter until you can pull it out with your fingers. The panel is replaced by pushing it back into place by hand.

WHIRLPOOL \ BUBBLEAIR™ INSTALLATION INSTRUCTIONS

WARNING! When using electrical products, basic precautions should always be followed, including the following:

DANGER: RISK OF ELECTRICAL SHOCK. Grounding is required. The unit should be installed by a qualified service representative. An equipment grounding terminal is provided in the field wiring compartment. To reduce the risk of electric shock, this terminal must be connected to the grounding means provided in the electric supply panel with a conductor equivalent in size to the circuit conductors supplying this equipment. The wiring must be installed by a qualified electrician and in compliance with all applicable National, State, or Provincial Electrical Code requirements, through a ground-fault circuit-interrupter (GFCI) of the Class A type.

An independent branch circuit c/w GFCI is required for each of the following options:

2 Whirlpool Pump Options: 120V – 60Hz – Max AMP Draw 8.5A Key pad or air button controlled
BubbleAir™ Blower: 120V – 60Hz – 9.5A Key pad controlled
Heater: 120V – 60Hz – 12.5A Flow switch controlled inside Heater

ALWAYS INSTALL TO PERMIT ACCESS FOR SERVICING.

WARNING:

- Pumps must be installed on the factory-provided mountings to ensure correct height for priming and draining.
- Access to the pump and electrical components must be provided to allow for installation & maintenance – where the optional removable access panel apron is not used, alternative access must be provided. (*Recommended size 9 ½" x 18"*)
- **Do not lift tub by any of the plumbing or electrical components.** Handle carefully to avoid damage during installation.
- All units are factory tested for operation and leaks, but **must** be checked for leaks, etc. before being finally closed in, or tiled.
- Before filling the tub for the first time, remove all construction residue and foreign materials, and rinse with clean water, to avoid introducing contamination or grit into the piping and pump.
- Building materials and wiring should be routed away from the pump body or other heat-producing components.
- When installing in an island setting some whirlpool models may require you to tip the unit from side to side tucking the plumbing under the decking one side at a time.

USER CARE & MAINTENANCE

The following hints on care and maintenance are offered to assist you in keeping your tub or shower in “as new” condition.

Normal Care:

A quick sponge-down with warm water and a liquid detergent such as Mr. Clean, Fantastic, or Lysol Tub and Tile Cleaner will take care of most cleaning needs. In areas where the water is hard, more frequent cleaning will be necessary to avoid a build up on the surface. We recommend that a good quality car or boat wax be applied occasionally – this will preserve the gloss and will make cleaning easier.

Stains:

For stubborn stains, start with a liquid detergent; if this does not work, try a mild powder detergent such as Spic and Span, which also works well for removing heavy soap film. Cleaning pads made of nylon, saran or polyethylene and containing no abrasives may be used. **Do not use abrasive scouring powders or metal scouring pads – they can permanently damage the finish.** A mild abrasive action can be accomplished with an automobile type of rubbing compound – there are several types available, both coarse and fine. The fine ones take a little longer to remove a stain, but they do not dull the surface as much.

Dull Areas:

Should your stain removal result in a dull area, the shine can be restored with an automobile cleaner wax, such as Turtle Wax.

Paint Splashes:

A quick wipe with mineral spirits, turpentine or Polyclens and then a wash with water will remove paint. **Do not use paint remover or stripper, as these contain solvents which could permanently damage the surface.**

Things to Avoid:

Sand and grit. Dropped tools.

Damage:

Should your unit suffer accidental damage, it is quite possible that it can be repaired by a qualified repairperson. Consult your plumber, wholesaler or a Hytec Sales Agent.

WARNING! Any problems, or damage to jetting or electrical components should only be corrected by a qualified service representative.



LIMITED 5 YEAR WARRANTY

All acrylic and gelcoat products manufactured by Hytec are covered by a 5-year warranty from the date of sale to the original owner. This warranty does not cover materials and component parts manufactured by others (such as pumps, jets, pipes, and fittings), which are subject to warranties offered by their original manufacturers. Hytec Plumbing Products warrants to the purchaser of each Hytec product that such product will at time of sale be free from defect in material and workmanship, and that Hytec will at its option repair the original unit or supply an equivalent unit in exchange, such exchange to be F.O.B. at Hytec warehouse. Hytec shall not be responsible for shipping, handling, or installation damage; or any expense of removal, transportation or installation of any original or exchange unit. Under no circumstances will Hytec Plumbing Products assume liability for consequential damages or labour charges resulting therefrom.

This warranty is non-transferable and shall be voided if the unit is removed from its place of initial installation or is not installed in accordance with the manufacturer's instructions. Further, this warranty does not apply if the unit has been subjected to accident, abuse, misuse, damage caused by flood, fire or act of God, or if the unit or the plumbing fixtures used in connection with it are not installed in compliance with local codes and ordinances. Any modifications or alterations to a unit, without prior authorization from Hytec Plumbing Products, or the installation of therapy jets by anyone other than Hytec Plumbing Products, will void all warranties. This includes the installation of steam generators.

HYTEC'S LIMITED WARRANTY OBLIGATIONS ARE EXPRESSLY LIMITED TO THOSE SET FORTH HEREIN, AND ARE IN LIEU OF ALL OTHER WARRANTIES, EXPRESSED OR IMPLIED. THE LIABILITY OF HYTEC TO THE BUYER WITH RESPECT TO THE SALE OF A UNIT SHALL BE LIMITED TO REPAIR OR REPLACEMENT AS PROVIDED HEREIN TO A MAXIMUM OF THE PURCHASE PRICE OF THE RELEVANT UNIT AND DOES NOT INCLUDE ANY COST OF REMOVAL OR REINSTALLATION OR CONSEQUENTIAL DAMAGES OF ANY KIND.

To obtain warranty service, contact Hytec Customer Service at **(800) 871-8311** or **(250) 546-3067**, or email **hytec.customer.service@kohler.com**. Please have ready all pertinent information regarding your claim, including a complete description of the problem, the product, model number, serial number and a copy of your original invoice. If the serial number is not available, please provide a digital photo of the unit.

Authorized Service Representatives for Hytec have been thoroughly trained to perform both in and out of warranty repairs to Hytec products. Through this training, they are familiar with the Hytec Warranty Policy. If in the opinion of the Authorized Service Representative, the service required is not within the scope of the Hytec Warranty Policy, they will advise you before beginning the work. Should this occur, payment of all invoices related to the service is the responsibility of the consumer. If the problem can be attributed to incorrect installation, please contact your installing contractor. Should there be a difference of opinion pertaining to warranty coverage between the Authorized Service Representative and the consumer; clarification will be provided by Hytec Customer Service.

**HYTEC PLUMBING PRODUCTS
(Division of Kohler Canada Co.)
4150 Spallumcheen Drive
Armstrong, BC, V0E 1B6
Phone (250) 546-3067 • Fax (250) 546-3170**

Please visit our website <http://www.hytec.ca> to find your local representative contact information.