

IMPORTANT – LEAVE THESE INSTRUCTIONS WITH THIS UNIT



Domeless Acrylic Showers and Tub Showers ONE-PIECE ACRYLIC FIXTURES INSTALLATION INSTRUCTIONS & FRAMING DIMENSIONS

(Please refer to additional instruction sheets for 2-piece Renovation Fixtures)

FRAMING DIMENSIONS

TOLERANCES $\pm 1/4"$ (6mm)

PRODUCT	MODEL	HEIGHT	WIDTH	DEPTH	C	D	DOOR OPENING
TUB SHOWER							
60" T/S RH Plumbing	AC62 H62	78 1/4" (1988mm)	60" (1524mm)	35" (889mm)	8 3/4" (222mm)	17 3/4" (451mm)	52 1/4" (1327mm)
60" T/S LH Plumbing	AC63 H63	78 1/4" (1988mm)	60" (1524mm)	35" (889mm)	8 3/4" (222mm)	17 3/4" (451mm)	52 1/4" (1327mm)
SHOWER STALL							
60" w/ Dbl. Seat	AC6370 H6370	78 1/4" (1988mm)	60" (1524mm)	37 1/8" (943mm)	30" (762mm)	18 1/2" (470mm)	52 1/4" (1327mm)
60" w/ No Seat	AC6371 H6371	78 1/4" (1988mm)	60" (1524mm)	37 1/8" (943mm)	30" (762mm)	18 1/2" (470mm)	52 1/4" (1327mm)
60" w/ Single LH Seat	AC6372 H6372	78 1/4" (1988mm)	60" (1524mm)	37 1/8" (943mm)	30" (762mm)	18 1/2" (470mm)	52 1/4" (1327mm)
60" w/ Single RH Seat	AC6373 H6373	78 1/4" (1988mm)	60" (1524mm)	37 1/8" (943mm)	30" (762mm)	18 1/2" (470mm)	52 1/4" (1327mm)

PLANNING

1. Be sure shower unit is positioned in the installation area before room is closed in.
2. Floor support under these models must provide for a minimum of 50 lb/square foot (244 kg/square meter) loading.
3. In locations where plumbing is adjacent to a masonry wall, provision must be made for access to connections.
4. When a fire-rated wall is specified, the finished fire-rated wallboards should be in place prior to installation of the unit (NOTE: In this case, allowance must be made for the thickness of the wall board when constructing the framing pocket.)
5. Tub/showers and shower stalls are designed to rest on their front apron and be supported by the nailing flanges along the sides and around the top – it is not necessary to support these units from the underside. However, in (a) knockdown renovation units, (b) where steel studs are in use, or (c) where it is not possible to support the unit around all the nailing flanges, it is advisable to support the underside of the shower floor; prevent possible damage by spreading the support over a large area of the floor or under the attached support feet.

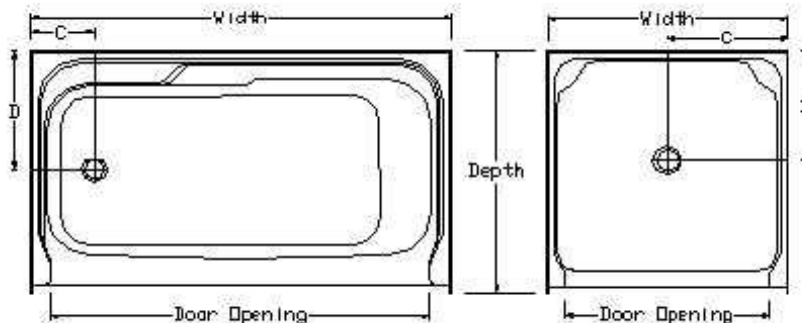

WARNING: Make sure a watertight seal exists on all drain connections (flange, gasket and thread).

IMPORTANT NOTE: For proper drainage, the maximum allowed tolerance for leveling is 1/8" over the length and width of the unit. HYTEC recommends the use of a digital or precision level.



INSTALLATION

1. Square and plumb a framed recess pocket to the outside dimensions of the unit, as shown in the table of dimensions. (Fig. 1)
2. Rough in supply line, but do not strap. (Fig. 1)
3. Locate correct position for drain and trap and cut out floor, leaving clearance for final positioning and hook up. (Fig. 1)
4. Mark unit for location of mixing valve, showerhead, etc. and drill from inside of unit with shade bit or hole saw.
5. Slide unit into position; check that all holes line up and that framing pocket is correct.
6. Remove from pocket and install shower drain, or waste and overflow. Install grout or mortar.
7. Replace unit in framed pocket, plumb and level, shimming out if necessary.
8. Predrill flange to avoid cracking during installation.
9. Secure nailing flange to studs with large head galvanized nails or flat head screws, 8" (203mm) on centre. (NOTE: Heads should not protrude too much or drywall installation may be affected.)

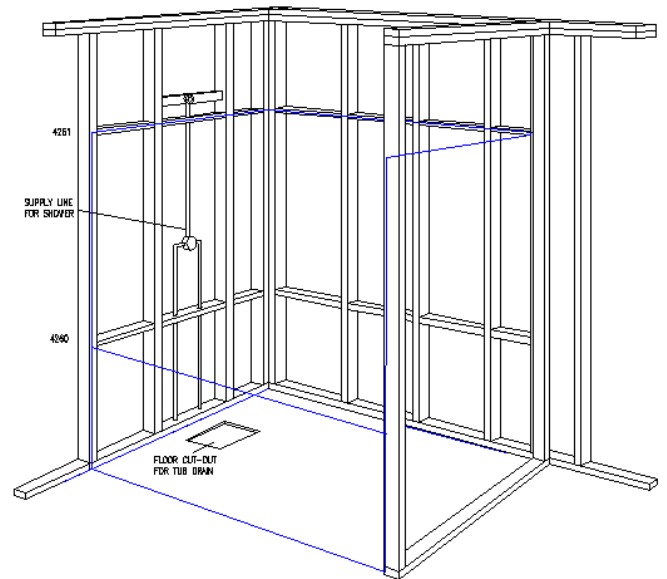

Fig. 1

DRYWALL

We offer two suggested methods for drywall installation:

METHOD A: Where tile will be used as the finished surface.

1. Drywall is butted up to the edge of the nailing flanges, and secured to the framing studs. A double thickness of drywall on the back flange is recommended.
2. Mud, tape, and finish drywall.
3. Attach tile to the drywall, with the bottom edge of the tile resting on the tile ledge.
4. Seal the joint between the tile and the unit, all the way around the unit, with a silicone or other water-resistant sealant.

METHOD B:

1. Apply furring strips to studs, up to edge of nailing flange.
2. Apply water-resistant sealer to horizontal nailing flange surfaces, then install wall board with factory finished edge (paper bound) $\frac{1}{4}$ " (6mm) above horizontal ledge. Where practical, wallboard should extend at least one stud beyond unit. A double thickness of drywall on the back flange is recommended.
3. Vertical nailing flanges should also be furred, and wallboard embedded in sealing compound.
4. Mud, tape and finish true and level.

FINISH:

1. Caulk all openings around valves and outlets with water-resistant sealant.
2. Install all finished faucet and drain trim, and shower door.
3. Protect finished installation against other construction damage.

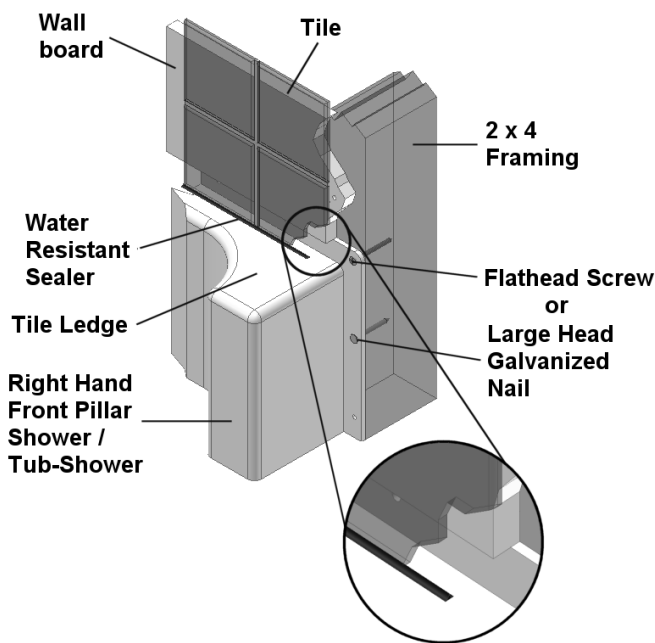

Method A

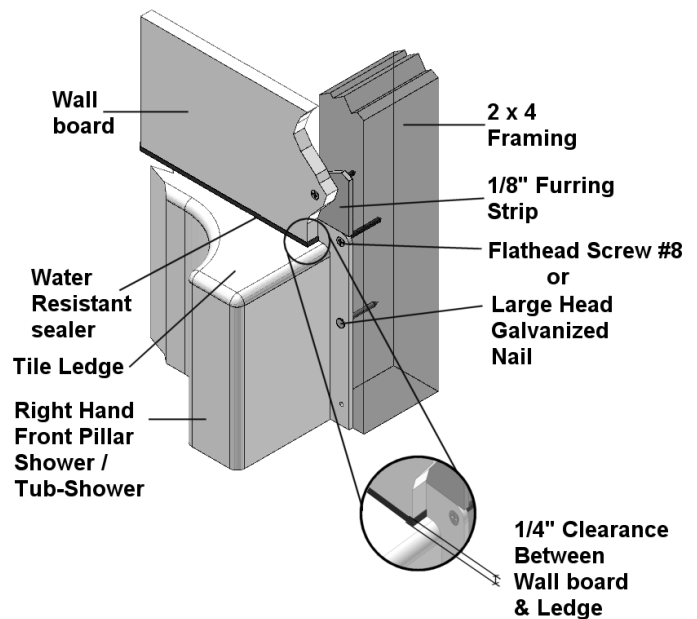

Method B

WHIRLPOOL INSTALLATION INSTRUCTIONS

WARNING! When using electrical products, basic precautions should always be followed, including the following:

DANGER: RISK OF ELECTRIC SHOCK. Grounding is required. The unit should be installed by a qualified service representative. An equipment grounding terminal is provided in the field wiring compartment. To reduce the risk of electric shock, this terminal must be connected to the grounding means provided in the electric supply panel with a conductor equivalent in size to the circuit conductors supplying this equipment. The wiring must be installed by a qualified electrician and in compliance with all applicable National, State, or Provincial Electrical Code requirements, through a ground-fault circuit-interrupter (GFCI) of the Class A type.

An independent branch circuit c/w GFCI is required for the following option:

Whirlpool Pump: 120V – 60Hz – 7.0A Air-switch controlled

ALWAYS INSTALL TO PERMIT ACCESS FOR SERVICING.

WARNING:

- Pumps must be installed on the factory provided mountings to ensure correct height for priming and draining.
- Access to the pump and electrical components must be provided to allow for installation and maintenance. Access must be provided. (*Recommended size 9 ½"x18"*)
- Do not lift by any of the plumbing or electrical components. Handle carefully to avoid damage to pump, piping or fittings, or electrical components.
- All units are factory tested for operation and leaks, but **must** be checked for leaks, etc. before being finally closed in, or tiled.
- Before filling the tub for the first time, remove all construction waste and foreign materials.
- Rinse the tub out with clean water before activating the pump, to avoid introducing contamination or grit into the piping and pump.
- Building materials and wiring should be routed away from the pump body or other heat-producing components.

WARNING! Any problems or damage to jetting or electrical components should be performed by a qualified service representative

USER CARE & MAINTENANCE

The following hints on care and maintenance are offered to assist you in keeping your tub or shower in “as new” condition.

Normal Care:

A quick sponge-down with warm water and a liquid detergent such as Mr. Clean, Fantastic, or Lysol Tub and Tile Cleaner will take care of most cleaning needs. In areas where the water is hard, more frequent cleaning will be necessary to avoid a build up on the surface. We recommend that a good quality car or boat wax be applied occasionally – this will preserve the gloss and will make cleaning easier.

Stains:

For stubborn stains, start with a liquid detergent; if this does not work, try a mild powder detergent such as Spic and Span, which also works well for removing heavy soap film. Cleaning pads made of nylon, saran or polyethylene and containing no abrasives may be used. **Do not use abrasive scouring powders or metal scouring pads – they can permanently damage the finish.** A mild abrasive action can be accomplished with an automobile type of rubbing compound – there are several types available, both coarse and fine. The fine ones take a little longer to remove a stain, but they do not dull the surface as much.

Dull Areas:

Should your stain removal result in a dull area, the shine can be restored with an automobile cleaner wax, such as Turtle Wax.

Paint Splashes:

A quick wipe with mineral spirits, turpentine or Polyclens and then a wash with water will remove paint. **Do not use paint remover or stripper, as these contain solvents which could permanently damage the surface.**

Things to Avoid:

Sand and grit. Dropped tools.

Damage:

Should your unit suffer accidental damage, it is quite possible that it can be repaired by a qualified repairperson. Consult your plumber, wholesaler or a Hytec Sales Agent.

WARNING! Any problems or damage to jetting or electrical components should be performed by a qualified service representative.



LIMITED 5 YEAR WARRANTY

All acrylic and gelcoat products manufactured by Hytec are covered by a 5-year warranty from the date of sale to the original owner. This warranty does not cover materials and component parts manufactured by others (such as pumps, jets, pipes, and fittings), which are subject to warranties offered by their original manufacturers. Hytec Plumbing Products warrants to the purchaser of each Hytec product that such product will at time of sale be free from defect in material and workmanship, and that Hytec will at its option repair the original unit or supply an equivalent unit in exchange, such exchange to be F.O.B. at Hytec warehouse. Hytec shall not be responsible for shipping, handling, or installation damage; or any expense of removal, transportation or installation of any original or exchange unit. Under no circumstances will Hytec Plumbing Products assume liability for consequential damages or labour charges resulting therefrom.

This warranty is non-transferable and shall be voided if the unit is removed from its place of initial installation or is not installed in accordance with the manufacturer's instructions. Further, this warranty does not apply if the unit has been subjected to accident, abuse, misuse, damage caused by flood, fire or act of God, or if the unit or the plumbing fixtures used in connection with it are not installed in compliance with local codes and ordinances. Any modifications or alterations to a unit, without prior authorization from Hytec Plumbing Products, or the installation of therapy jets by anyone other than Hytec Plumbing Products, will void all warranties. This includes the installation of steam generators.

HYTEC'S LIMITED WARRANTY OBLIGATIONS ARE EXPRESSLY LIMITED TO THOSE SET FORTH HEREIN, AND ARE IN LIEU OF ALL OTHER WARRANTIES, EXPRESSED OR IMPLIED. THE LIABILITY OF HYTEC TO THE BUYER WITH RESPECT TO THE SALE OF A UNIT SHALL BE LIMITED TO REPAIR OR REPLACEMENT AS PROVIDED HEREIN TO A MAXIMUM OF THE PURCHASE PRICE OF THE RELEVANT UNIT AND DOES NOT INCLUDE ANY COST OF REMOVAL OR REINSTALLATION OR CONSEQUENTIAL DAMAGES OF ANY KIND.

To obtain warranty service, contact Hytec Customer Service at **(800) 871-8311** or **(250) 546-3067**, or email **hytec.customer.service@kohler.com**. Please have ready all pertinent information regarding your claim, including a complete description of the problem, the product, model number, serial number and a copy of your original invoice. If the serial number is not available, please provide a digital photo of the unit.

Authorized Service Representatives for Hytec have been thoroughly trained to perform both in and out of warranty repairs to Hytec products. Through this training, they are familiar with the Hytec Warranty Policy. If in the opinion of the Authorized Service Representative, the service required is not within the scope of the Hytec Warranty Policy, they will advise you before beginning the work. Should this occur, payment of all invoices related to the service is the responsibility of the consumer. If the problem can be attributed to incorrect installation, please contact your installing contractor. Should there be a difference of opinion pertaining to warranty coverage between the Authorized Service Representative and the consumer; clarification will be provided by Hytec Customer Service.

HYTEC PLUMBING PRODUCTS
(Division of Kohler Canada Co.)
4150 Spallumcheen Drive
Armstrong, BC, V0E 1B6
Phone (250) 546-3067 • Fax (250) 546-3170

Please visit our website <http://www.hytec.ca> to find your local representative contact information.