



BEFORE YOU BEGIN

INSTALLER HAZARD NOTIFICATION

 **WARNING: Risk of injury or water damage.** Contents of vessel under pressure can cause severe injury. Do not open or service before reading installation instructions or service instructions. Turn off water supply and flush unit to release pressure before attempting any service.

 **CAUTION: Risk of product damage.** Do not use any oils or lubricants on the Pressure Lite™ system.

 **CAUTION: Risk of product damage.** The fittings in this toilet require no adjustment (except for possible gap clearance adjustment and winterizing, refer to Page 6). The fittings in this toilet are preset. Any adjustment or modifications of the product are not normal usage and void the warranty.

 **WARNING: Risk of injury or product damage.** Handle vitreous china products very carefully. Vitreous china can break and chip if you over-tighten bolts and nuts.

NOTICE: For service and warranty on the Sloan Flushmate vessel and related components, see the Sloan Flushmate Owner's Service Manual (included). **Follow all local plumbing codes.**

PRODUCT PROPERTIES

- Pressure Lite System.
- Water surface to rim is 6-7/8" (17.5cm).
- 2-1/4" (5.7cm) passageway.
- For roughing-in and overall dimensions, see diagram on Page 3.
- Fixture dimensions are nominal and conform to tolerances by ANSI/ASME Standards (A112.19.2).

NOTICE: Due to the pressure within the vessel, the flush noise level may be higher than that of a gravity flush toilet.

PRODUCT REQUIREMENTS

- The supply stop should be 8" (20.3cm) above the floor line, and 7" (17.8cm) to the left of the closet flange centerline.
- Since all toilets do not have the same supply rough-in, you may have to change the location of the supply stop to install this toilet.
- Closet flange must be 12" (30.5cm) on-center from wall.
- Seat post holes are on 5-1/2" (14cm) centers.
- For most satisfactory operation, the toilet requires 20 p.s.i. (1.3Kg/cm²) static pressure minimum at the supply stop. The pressure is not to exceed 80 p.s.i. (5.5Kg/cm²) maximum static pressure.

ORDERING INFORMATION

Toilet K-3458

When specified:

3/8" supply K-7637

Floor bolts 21401

NOTE: For service parts ordering information, see the label on the underside of the tank cover.

NOTICE: For service and warranty on the Sloan Flushmate vessel and related components, see the Sloan Flushmate Owner's Service Manual (included).

MATERIALS REQUIRED

- Supply stop (3/8" recommended)
- Toilet seat
- Closet flange
- Toilet gasket (wax seal)
- Toilet T-bolts 1/4" (6mm) or 5/16" (8mm) diameter (2 required)
- Toilet supply tubing

TOOLS REQUIRED

- 10" adjustable wrench
- Tubing cutter
- Hacksaw
- Level
- Putty knife
- Metal file
- Tape measure
- Screwdriver

NOTE: Site preparation may require additional tools.

SITE PREPARATION

REMOVE EXISTING TOILET

NOTICE: Carefully inspect new fixture for any sign of damage before removing existing toilet. If any damage to vitreous china or Pressure Lite system components are discovered, stop installation and call place of purchase for assistance.

Inspect the complete toilet to ensure that the:

- Components are attached securely.
- Trip lever and plunger arm move freely.
- Vessel is securely mounted.
- Vitreous china is undamaged.

Turn off the water supply.

Flush the toilet, and sponge out all remaining water from the tank and bowl.

Disconnect the supply stop, and remove the old tank and bowl.

Remove the old gasket from the floor and closet flange with a putty knife.

Remove the old T-bolts (the T-shaped bolts in the closet flange), and discard.

 **CAUTION: Risk of hazardous gases.** If the new toilet is not installed immediately, temporarily stuff a rag in the closet flange.

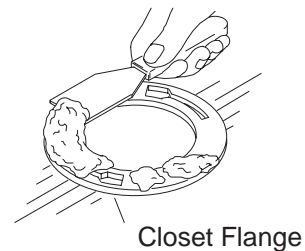

ROUGH-IN PLUMBING

Turn off the water supply.

Install or relocate the supplies and outlets as necessary to conform to the roughing-in dimensions. For supply stop location, refer to Page 3.

 **CAUTION: Risk of trap seal loss in back-to-back installations.** To prevent possible trap seal loss, the back-to-back Pressure Lite toilet must be connected to a vertical stack using one of the following three fittings:

- Double fixture fitting
- Double combination wye and 1/8 bends
- Double wye and 1/8 bends

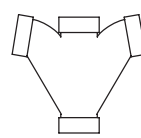

**Double
Fixture
Fitting**

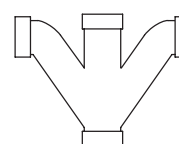

**Double
Combination
Wye and 1/8
Bends**

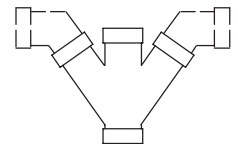

**Double Wye
and 1/8
Bends**

ROUGHING-IN DIMENSIONS

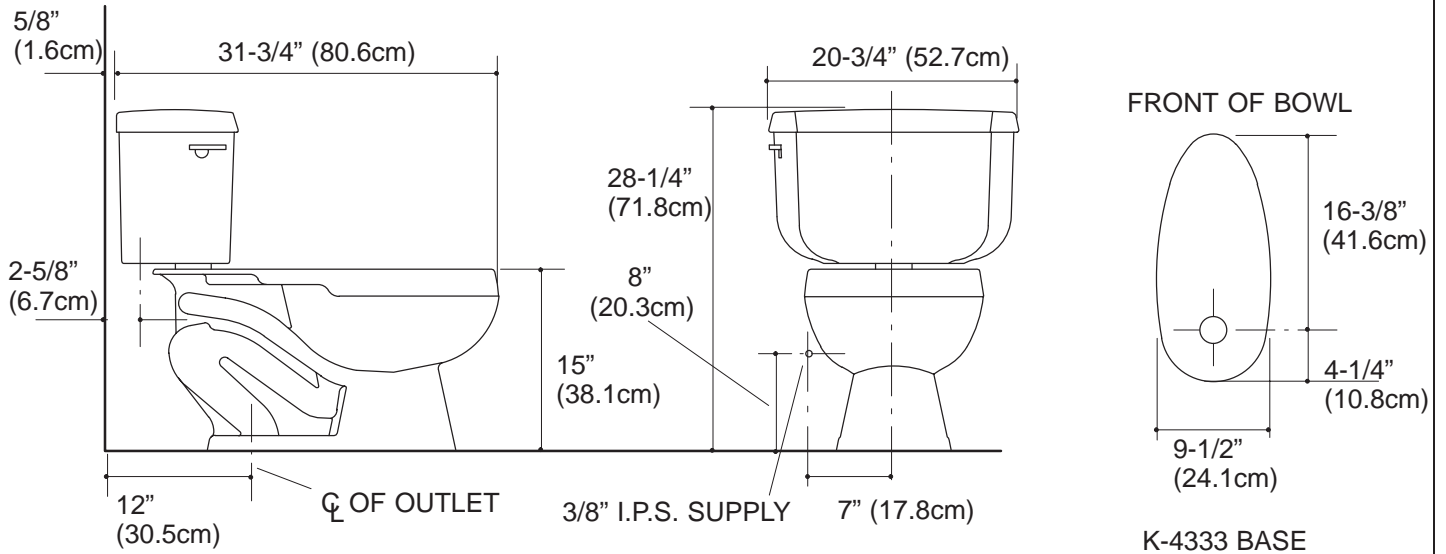

INSTALL SUPPLY STOP

For supply installation, refer to the instructions packed with the supply stop.

Locate the supply stop so it is 8" (20.3cm) above the floor line, and 7" (17.8cm) to the left of the closet flange centerline.

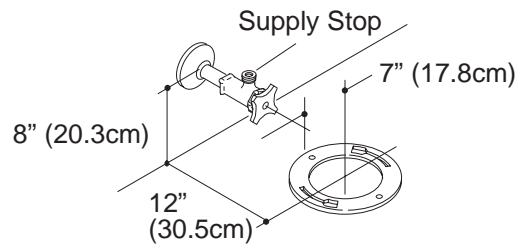

Install new 1/4" (6mm) or 5/16" (8mm) diameter T-bolts.

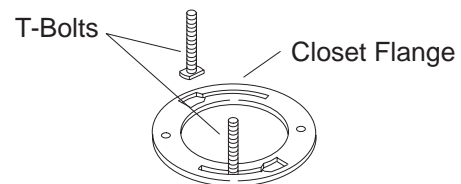

INSTALLATION

INSTALL TOILET GASKET

Set the new toilet upside down on padding.

Firmly press the gasket onto the toilet outlet. If you are using a gasket with an integral plastic sleeve, position the gasket with the sleeve facing away from the toilet.

NOTE: If a rag or other plug was put in the closet flange, remove the rag from the closet flange before setting the toilet.

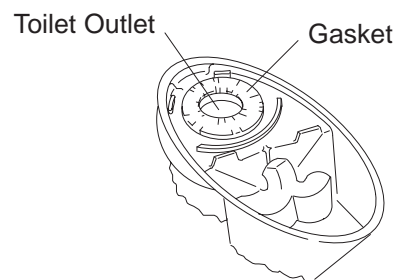

ALIGN AND SET TOILET

Carefully align and lower the toilet over the closet flange and T-bolts.

WARNING: Risk of product or water damage. Do not lift or rock the toilet after placement. A new gasket must be installed if you break the watertight seal.

Apply full body weight to toilet rim to set seal.

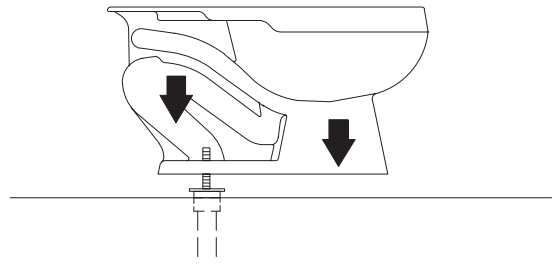

SECURE TOILET

Assemble the bolt cap bases, washers, and nuts on the exposed T-bolts.

CAUTION: Risk of personal injury or product damage. Overtightening may cause breakage or chipping of the vitreous china.

Hand-tighten the nuts, then tighten them an additional 1/2-turn with a wrench. If the T-bolts extend more than 1/4" (6mm) from the top of the nut, cut off any excess with a hacksaw, and file the cut edges. Wipe away any residue.

Install the bolt caps.

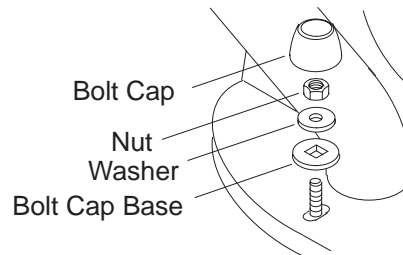

INSTALL TANK

Set the tank on the bowl, using the bolts as a guide. Center the gasket on the inlet of the bowl.

Assemble the washers and brass hex nuts onto the bolts, and hand-tighten evenly.

Alternately tighten the brass hex nuts so the top of the tank is level with the top of the bowl. Pushing down on the top of the tank will make it easier to tighten the brass hex nuts.

Tighten the brass hex nuts one or two turns past hand tight to obtain a level tank and watertight seal.

CAUTION: Risk of personal injury or product damage. Overtightening may cause breakage or chipping of the vitreous china.

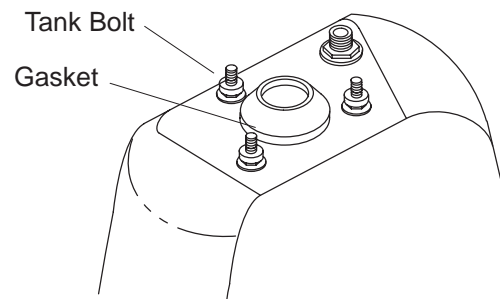

CONNECT SUPPLIES

Carefully bend the supply stop tubing to fit. Measure for required penetration into the supply stop. Cut and de-burr the tubing. Install the connection hardware onto the tubing as shown. Hand-tighten the coupling nut first, and then the compression nut.

WARNING: Risk of property damage. Do not overtighten or you may deform the connections and cause a leak. **Do not use tools to tighten plastic nuts.**

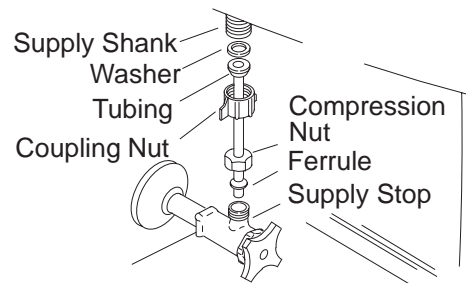

PRESSURE LITE SYSTEM

WARNING: Risk of personal injury or water damage. Contents of the vessel are under pressure, and can cause severe injury. Do not open or service before reading installation instructions or service instructions. Turn off the water supply, and flush the unit to release pressure before attempting any service.

CAUTION: Risk of product damage. Do not use any oils or lubricants on the Pressure Lite system.

OPERATION

The vitreous china bowl and tank direct the flushing water flow, and house the Pressure Lite system.

The vessel contains the complete operating cartridge assembly, and is the container for the pressurized 1.6 gallons (6.1 L) of water used for each flush.

The control components consist of the pressure regulator and the air inducer. These components work with the incoming, pressurized, supply-line water to provide a regulated pressure flush to the toilet bowl.

A complete flush cycle is two separate functions.

When the trip lever is operated, the vessel plunger assembly is pressed, allowing pressurized water to be directed to the bowl for complete flushing action. As the water level in the vessel drops the plunger will close, stopping water flow to the bowl.

A checkport built into the vessel assembly allows any discharge of water into the vitreous tank to drain directly into the bowl.

After flushing, a charge cycle takes place. Supply line water flows into the vessel through the screen and pressure regulator. The water then flows across the air inducer, which mixes a small amount of air with the water, filling the vessel until a pressure of approximately 35 p.s.i. (2.5Kg/cm²) is reached. The toilet will be ready for the next flush within 60 to 90 seconds. If the toilet is not ready for the next flush within that time, please refer to the troubleshooting chart on Page 7.

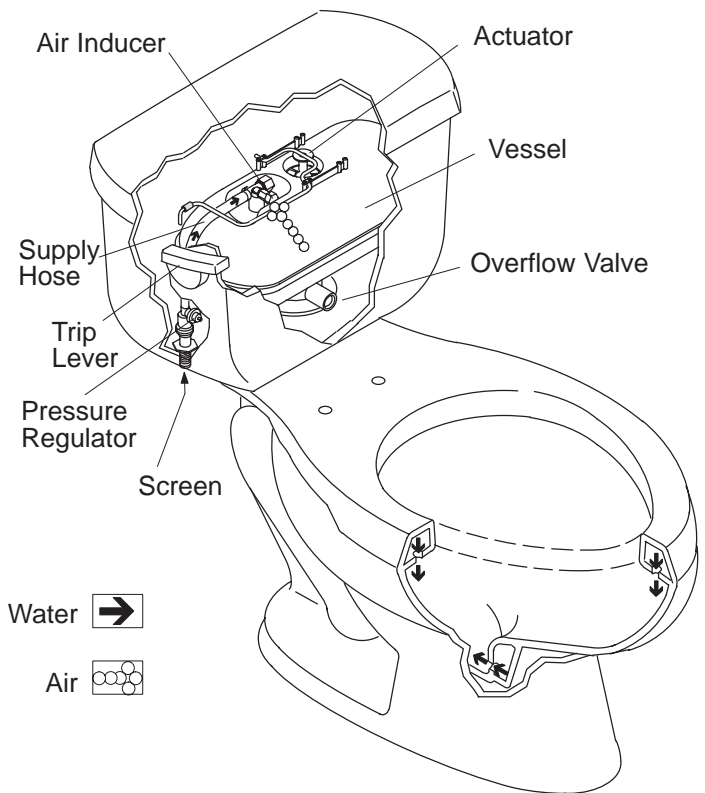

START-UP

Turn on the water supply to bring the Pressure Lite system to its operating pressure (approximately 1 minute).

Check for leaks. Slight retightening of any leaking connections should stop seal leaks.

If the toilet is leaking between the tank and bowl, carefully retighten the three tank bolts evenly. Check all bowl and tank connections for leaks for several days.

Flush and repressurize the toilet three times to stabilize the system.

GAP CLEARANCE

If the toilet does not activate, the gap between the actuator and plunger arm may need to be reset. Make sure the trip lever handle is installed, and the trip lever nut is tight. This is a left-hand thread; turn counterclockwise to tighten.

Make sure the water supply is on, and the supply line water has stopped flowing into the toilet.

Loosen the setscrew. Turn the actuator until there is a $1/16''$ (2mm) – $3/32''$ (2.4mm) gap between the actuator and the plunger arm. Turn the actuator clockwise to increase the gap. Tighten the setscrew after the gap is properly adjusted.

NOTE: Loss of gap clearance adjustment could cause leakage into the toilet bowl due to the plunger not sealing properly. This condition could cause a continual flow of water. If the problem is not corrected after adjustment, refer to the troubleshooting chart on Page 7.

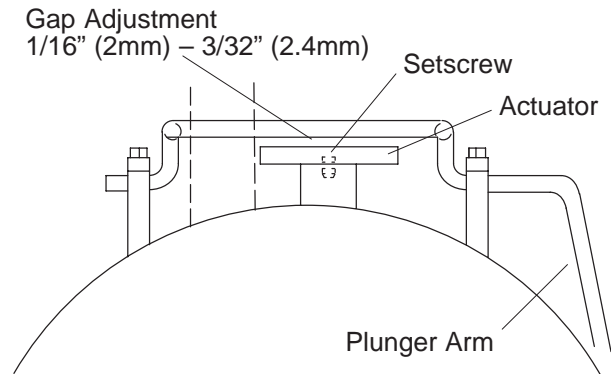

INSTALL SEAT

To install, use the seat attachment hardware and instructions packed with the toilet seat.

MAINTENANCE

WINTERIZING

Shut off the water supply.

Flush the toilet. Press the actuator down for approximately one minute to drain water from the vessel assembly.

Disconnect the supply line.

Remove the supply shank, and drain the water from the tank.

Press the actuator one more time, then pull it up to allow air into the vessel.

Add antifreeze to the toilet bowl water to prevent freezing. Use recreational-type antifreeze commonly used in campers, motor homes, and boats.

For start up, connect water supply and refer to the Start-Up section on Page 5.

NOTE: Refer to the Sloan Flushmate Owner's Service Manual (included) for more information.

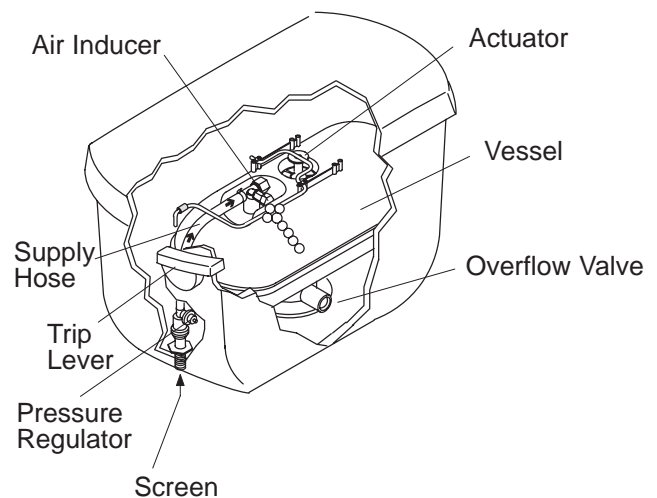

TROUBLESHOOTING

The troubleshooting guide below is meant for general aid only. All fittings in this toilet except for the plunger nut are preset by the manufacturer to prevent adjustment. Any attempt to adjust the fittings (except for gap clearance and winterizing) may damage the toilet. Such adjustments for modifications of this product are not normal usage and will void the warranty. For proper trip lever adjustment procedures, refer to Gap Clearance on Page 6 in these instructions. Any problems, technical questions, or warranty issues involving the vessel or its related components should be directed to **1-800-533-3450**. Any other problems not covered in this chart should be referred to your installer/dealer.

SYMPTOM	POSSIBLE CAUSE	CORRECTIVE ACTION
1. No flush.	<ul style="list-style-type: none"> A. Supply stop is closed. B. Trip lever is loose. C. Trip lever does not actuate plunger. D. Obstruction within water inlet components. E. Screen is clogged. 	<ul style="list-style-type: none"> A. Fully open supply stop. B. Tighten nut (turn counterclockwise to tighten). C. Adjust linkage or actuator gap (refer to Page 6). D. Replace inlet components. (Phone 1-800-533-3450 for assistance.) E. Clean the screen. (Phone 1-800-533-3450 for assistance.) Replace the screen if necessary.
2. Poor flush.	<ul style="list-style-type: none"> A. Bowl rim holes are clogged. B. Trapway or drain line is clogged. C. System is not pressure charged. D. Supply stop is not opened. E. Drain line vent is clogged. F. Screen is clogged. 	<ul style="list-style-type: none"> A. Clean under bowl rim. B. Plunge bowl, auger trap, auger drain to clear blockage. C. Adjust plunger adjuster for proper actuation arm gap (refer to Page 6). D. Fully open supply stop. E. Refer to installer/dealer for assistance. F. Clean the screen with a medium to hard bristle brush. Replace the screen if necessary. (Phone 1-800-533-3450 for assistance.)
3. Bowl water continues to flow or tank fill water will not shut off.	<ul style="list-style-type: none"> A. Plunger is not seating properly. B. Plunger arm is binding. C. Pressure regulator is not working. 	<ul style="list-style-type: none"> A. Adjust gap between actuator and plunger arm (refer to Page 6). B. Repair or replace plunger arm (refer to installer/dealer for assistance). C. Replace the lower supply group. (Phone 1-800-533-3450 for assistance.)

IMPORTANT CONSUMER INFORMATION

CONSUMER RESPONSIBILITIES

If you live in a hard water area, you should make certain that the holes in the rim are kept clean for proper bowl flushing. Toilet bowl cleaners should be used at least once a week. Use a long-handled brush to clean the rim holes and to clean as far into the trap as possible to prevent mineral deposits from forming.

Cleaning of the Pressure Lite tank system is not necessary. If cleaning is desired, use mild soap and water.

Most toilet bowl cleansers are not harmful to the vitreous china surface of the toilet bowl. Please follow the bowl cleanser manufacturer's instructions carefully.

Do not use abrasive cleaners or solvents.

REQUESTING SERVICE

Please take a moment to familiarize yourself with the Kohler Warranty, its benefits, and limitations. Kohler Co. and its distributors support you with one of the largest Service Networks of its type. Here's what you need to do if you require service:

FIRST: Contact the dealer or contractor who sold and installed the product. They should be able to solve any problems you may have.

SECOND: If your dealer or contractor cannot solve the problem, they will contact or supply you with the name of the local Kohler Distributor and the:

 KOHLER TECHNICAL SPECIALIST

THIRD: If you are unable to obtain warranty service through either your contractor or Kohler Co. distributor, please write us directly at Kohler Co., Attn: Customer Service Department, 444 Highland Drive, Kohler, WI 53044 U.S.A.

Any problems, technical questions, or warranty issues involving the Sloan Flushmate vessel or its related components should be directed to Sloan at 1-800-533-3450.

FOURTH: Include all pertinent information regarding your claim, including a complete description of the product, model numbers, colors, finishes, and the date the product was installed. Include a description of the problem, and a photocopy of your invoice for the products involved. Also give us the name of the contractor and distributor.

LIMITED ONE-YEAR WARRANTY

Kohler plumbing fixtures and fittings are warranted free of manufacturing defects.

Kohler Co. will, at its election repair, replace, or make appropriate adjustment where Kohler Co. inspection discloses any such defects occurring in normal usage within one year after installation. **Kohler Co. is not responsible for installation or removal costs.**

To obtain warranty service, contact Kohler Co. either through your Dealer or Plumbing Contractor or by writing Kohler Co., Attn: Customer Service Department, 444 Highland Drive, Kohler, WI 53044 U.S.A., or by calling **1-800-4-KOHLER** from within the U.S.A.

Implied warranties, including that of merchantability or fitness for a particular purpose, are expressly limited in duration to the duration of this warranty. Kohler Co. disclaims any liability for special, incidental, or consequential damages.

Some states do not allow limitations on how long an implied warranty lasts or the exclusion or limitation of special, incidental, or consequential damages, so these limitation and exclusion may not apply to you. This warranty gives you specific legal rights. You may also have rights which vary from state to state.

This limited warranty provides specific legal rights as they apply within the U.S.A., and other rights may be available, but may vary from country to country.

This is our exclusive written warranty.

KOHLER CO., KOHLER, WISCONSIN, 53044