

16294T 恒温阀体

安装之前

所有的资料是按最新出版的产品资料编写而成。科勒公司保留任何时候不经通知即可改变产品特性、包装或产品可供类型的权利。

说明书包括重要的安装、保养及清洁方面的内容,请把这些资料交给用户阅读。

注意事项:

- 1.如果配合多个感应龙头使用,需构建平衡管路,如 Fig.1 所示。
- 2.在水压不低于 0.3Mpa(3bars)情况下,一个恒温阀体推荐的服务感应龙头的数量不多于 4 个。
- 3.如采用埋墙式安装,埋墙前测试安装连接部位是否有渗漏,根据需要修理之。

使用环境

1. 最小供水压力: 0.5 bar(0.05MPa)。
2. 推荐冷热供水压力: 3bars(0.3MPa)。
3. 如果供水压力大于 5bars(0.5MPa),安装减压阀。
4. 冷热供水的压力差不大于 2bars(0.2MPa)。
5. 热供水温度最低: 50°C; 最高: 70°C。
6. 推荐的热供水温度: 60°C。
7. 温度调整的基本范围为: 20°C 到 50°C。
8. 安全限位温度: 40°C

安装尺寸

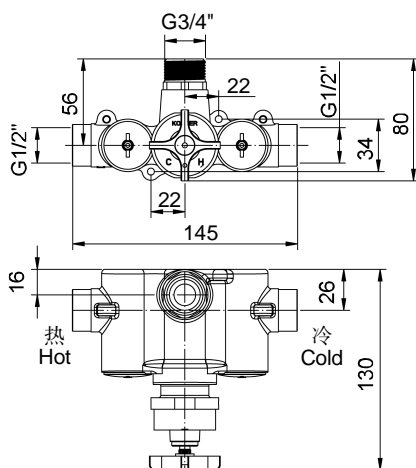

BEFORE YOU BEGIN

All information is based on the latest product information available at the time of publication. Kohler Co. reserves the right to make changes in product characteristics, packaging, or availability at any time without notice.

Please leave these instructions for the consumer. They contain important information.

Notes:

- 1.If thermostat valve works with more than one sensor faucets, should construct a pressure balancing pipe loop as Fig.1 shown.
2. Recommended 4(max) sensor faucets supplied by one thermostat valve when system water pressure is above 0.3Mpa(3bars).
- 3.If the valve system is recessed. Check for leaks before covering the pipes, repair as needed.

OPERATION CONDITION

1. Minimum supply pressures: 0.5 bar.
2. Recommended supply pressures: 3 bars on hot and cold water.
3. If supply pressure higher than 5 bars: install a pressure reducer.
4. Pressure difference between hot and cold supply: 2bars maximum.
5. Hot supply water temperatures, minimum: 50°C, maximum: 70°C.
6. Recommended hot supply water temperature: 60°C(energy-saving).
7. Setting range, approximately: 20°C to 50°C.
8. Safety stop at: 40°C.

ROUGH-IN DIMENSIONS

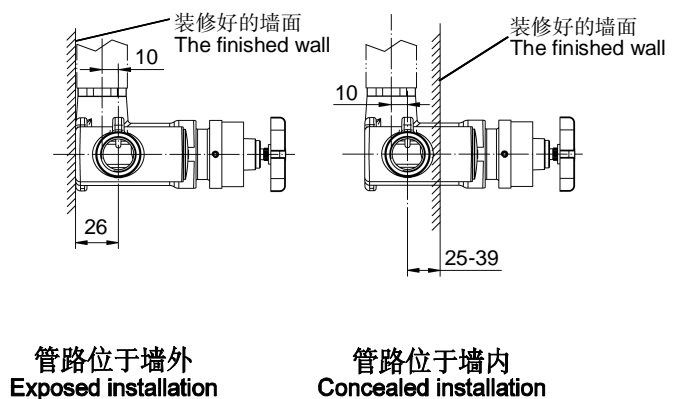

安装步骤

安装平衡管路

如果配合多个感应龙头使用,需构建如 Fig.1 所示的平衡管路。

注意:在水压不低于 0.3Mpa (3bars)情况下,一个恒温阀体推荐的服务感应龙头的数量不多于 4 个。

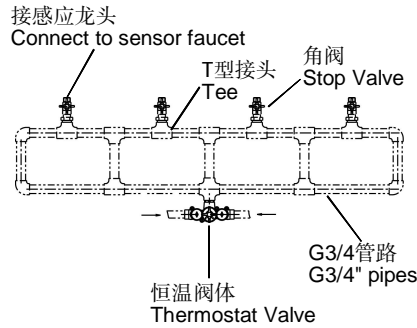

Fig.1

INSTALLATION

How to Install Balancing Piping Loop

If thermostat valve works with more than one sensor faucets, should construct a pressure balancing pipe loop as Fig.1 shown.

Note: Recommended 4(max) sensor faucets supplied by one thermostat valve when system water pressure is above 0.3Mpa(3bars).

如何安装阀体

一定要先彻底冲洗供水管以清除管道中的杂质。关闭水源。

选择合适的高度安装阀体(1)。

如果管路位于墙内,阀体进水孔中心到外墙面的距离应控制在 25-39mm 之间。

注意:安装时保证阀轴线与墙面垂直。

如 Fig.3 所示,将 G1/2" 冷热供水管、出水管接到阀体上。热水管接到左侧。

各螺纹处须缠绕足以密封的密封胶带或适合的密封胶。

注意:如果管路不足以支撑阀体,根据需要构建支架。根据安装尺寸和胀塞(3)直径在墙面或支架上打孔,安装胀塞。用螺钉(4)穿过阀体安装孔(2)将阀体固定在墙体或支架上。

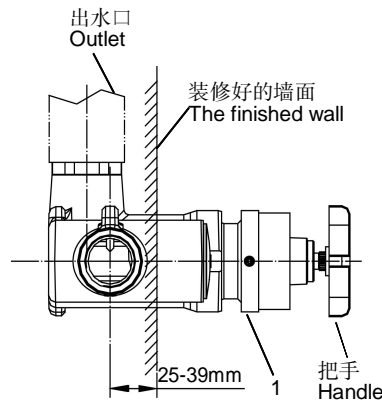

Fig.2

How to Install the Valve

Flush the water supply pipes thoroughly to remove debris before installation. Shut off the main water supply.

Determine where the valve body(1) will be located on the wall.

For concealed installation, the dimensions from the centerline of the inlet for the valve body to the surface of the finished wall should be within 25-39mm.

Note: Ensure the centerline of valve is perpendicular to the wall.

Connect G1/2" hot & cold supplies, and outlet pipe to valve body as Fig.3 shown. Connect hot supply to the port on the left.

Supply enough tape or sealant to all connections.

If the pipes are not strong enough to support the valve, construct a frame as required. Drill holes on the finished wall or the frame according to the rough-in dimensions and diameter of the anchor(3). Press the anchors into the holes. Secure the valve body on the wall or frame with screws(4) through mounting holes(2).

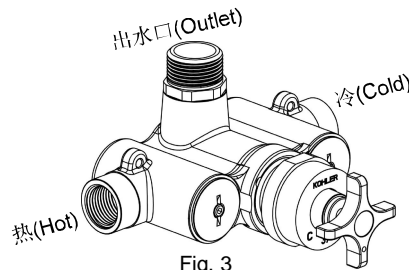

Fig. 3

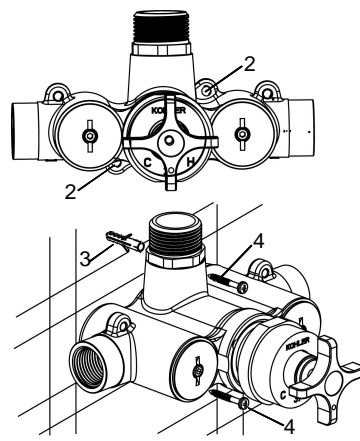

Fig. 4

安装后检查

确保所有衔接螺母都已锁紧。确保阀体处于关闭的位置。开启冷热水源,检查是否有漏水。如漏水,修理之。

使用说明

慢慢旋转温控把手来调整温度。安全限位温度为 40°C 。如果想得到更高的温度,通过逆时针旋转把手调整。

温度测试与调整

在温度测试前,应确保供水系统充分,并且热水具有推荐的温度范围内的较高的温度。温控把手在 37°C 位置时,打开龙头让水流出。进行温度测量,出厂时温度设定在 $36\sim 38^{\circ}\text{C}$ 范围内。如果超出了这个范围,要进行调整。调整的步骤如下:

卸下温控把手组件:小心取下把手塞扣(8),用螺丝刀取下螺钉(7)和十字把手(6)。

在正常水流的状态下,由冷水位置开始慢慢转动温控阀轴(5)(保持同一方向)直至获得 37°C 水流。如果温度超过 38°C ,回到冷水位置重新调整。

温度稳定后,不要转动温控阀轴,装回把手组件。

注意:安装把手时,确保十字把手上带圆点的一端与帽盖上的数字 37 标识对齐,如 Fig.6 所示。

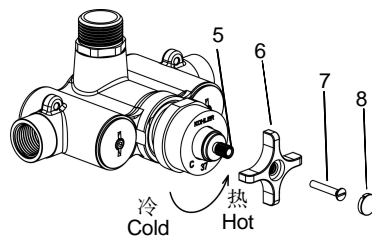

Fig. 5

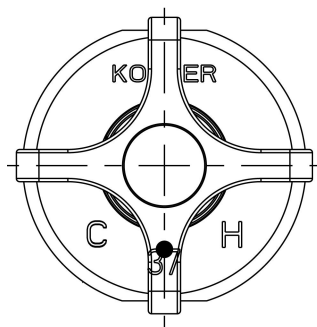

Fig. 6

INSTALLATION CHECKOUT

Ensure that all coupling nuts are tightened and the valve system is in the close position. Turn on the cold and hot water supplies and check for leaks. Repair as needed.

OPERATION INSTRUCTIONS

The temperature is set by slowly turning the temperature handle. For safety reasons, there is a stop that limits temperature to 40°C . To get a higher temperature, continue turning the temperature handle counter-clockwise.

Temperature Verification and Setting

Make sure that the water feeds of the faucet have reached their highest temperature but within the recommended range by letting the water run sufficiently. With the selector in position 37°C , the temperature of the water coming out of the faucet must be within a range of 36°C and 38°C , as measured by a thermometer. If the temperature out of the range, the installer can adjust the setting. Proceed with the setting as follows:

Remove the temperature handle kit: Carefully remove the handle plug(8). Unscrew the screw (7) with the screwdriver, remove the cross handle(6).

With the faucet on "cold" normal water flow, slowly turn the temperature selector(5) (always in the same direction) until water at 37°C is obtained. If the temperature goes over 38°C , go back to the "cold" setting and set again.

When the temperature is stabilized, without turning the cartridge spindle, reinstall the handle kit.

Note: Ensure the branch with dot of cross handle is aligned with the number 37 on bonnet, as Fig.6 shown.

温控阀清洗

如果供水的水质较硬或长时间使用,水垢或杂质会阻塞温控阀上的滤网,流量降低。需要清理请按照下列步骤进行:

关闭供水系统,使流量阀处于打开位置后进行温控阀的拆卸作业。温控阀是较敏感的配件,所以要十分小心。

拆卸前确保使十字把手圆点标识与帽盖(10)的数字 37 标识对齐。按前述方法卸下温控把手组件,用 2mm 六角扳手旋松螺钉(9),取下帽盖(10)。然后将加长杆(11)、限位套(12)和限位组件(13)卸下(图 Fig.7)。小心地卸下温控阀(14)用热醋进行清洗。

清洗后,将限位组件装到温控阀上,使塑料套的定位柱嵌入温控阀的限位槽内(图 Fig.8)。然后将塑料套的定位柱与龙头本体内孔凹槽对齐,装入温控阀并锁紧螺母(图 Fig.9)。装回限位套和加长杆,保证限位套上的圆点标记与限位组件上的弧形凸起中心对正(图 Fig.10)。保持 KOHLER 标志朝上装回帽盖,拧紧螺钉。按前述方法装回温控把手组件。

注意:要确保拆卸、安装过程中,不要转动温控阀轴。如不小心转动了阀轴,要调整阀轴使外齿上的黑线标识与相邻塑套上的凹槽对齐(图 Fig.11),或按前述的温度测试与调整的方法进行温度的确认调整。

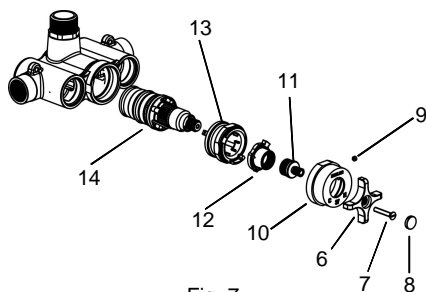

Fig. 7

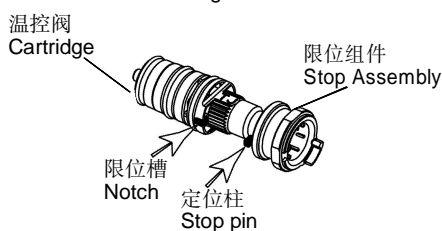

Fig. 8

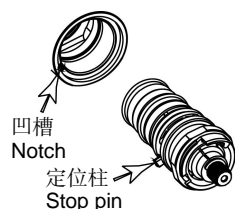

Fig. 9

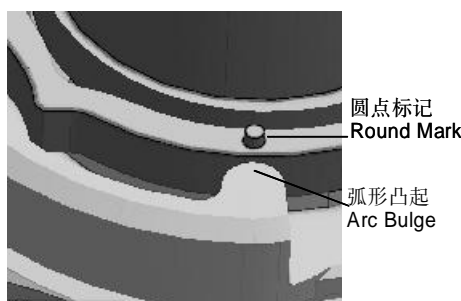

Fig.10

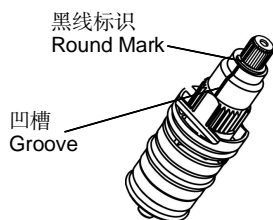

Fig. 11

Clean Thermostatic Cartridge

Very hard water can obstruct the filters on thermostatic cartridge and reduce the flow of water. Please clean the cartridge as follows:

Shut off the water supplies of the faucet and open the flow valve, then proceed to remove the cartridge. The cartridge is sense organ, please be careful.

Make sure round mark on cross handle aligned with the number 37 on bonnet(10) before your action. Remove the temperature handle kit according to the process in previous page. Loosen the screw (9) by 2mm hex wrench, take off the bonnet. Remove stem(11), detent(12) and stop assembly(13)(Fig.7). Removing the thermostatic cartridge(14) cautiously. Clean the thermostatic cartridge by soaking it in warm vinegar.

After cleaning, install the "stop assembly" back on the cartridge, adjusting the stop pin into the notch(Fig.8). Install the cartridge and stop assembly into the body, adjusting the stop pin into the notch(Fig.9). Reinstall the detent and stem. Align the round mark on the detent with the arc bulge on the stop assembly (Fig.10). Keep the KOHLER mark upwards, reinstall the bonnet. Tighten the screw. Reinstall the temperature handle kit according to the process in previous page.

NOTE: Do not turn the cartridge when reinstall it. If you turned it without carefulness, you should adjust it and be sure that the black line mark is correctly in line with the groove(Fig.11). For accurate temperature, it is supposed to verify and resetting the cartridge according to instruction in previous pages.

清洗单向阀过滤组件滤网

该龙头的单向阀过滤组件内已包含了优良的过滤装置如果供水的水质较硬或长时间使用,水垢或杂质会阻塞进水滤网,流量降低。需要清理请按照下列步骤进行:

- 1) 用提供的内六角扳手(18)顺时针方向拧紧单向阀过滤组件制动杆(15),关闭单向阀过滤组件;
- 2) 用专用钥匙(19)或硬币逆时针方向旋下单向阀过滤组件固定螺帽(17);
- 3) 取出滤网(16),冲洗完毕后重新装入;
- 4) 用专用钥匙或硬币顺时针方向拧紧单向阀过滤组件固定螺帽,再用内六角扳手逆时针方向打开单向阀过滤组件的制动杆即可。

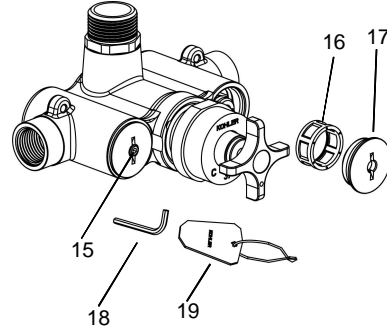

Fig. 12

Clean Filters for Check Valve and Filtration Kits

The check valve and filtration kits are equipped with high quality filters. If there is a lot of debris in the supply pipes or the quality of water is bad, it will cause the flow in bad condition. Please clean the filters as following steps:

- 1) Turn clockwise the stoppers(15) with the hex wrench(18) provided to close the check valve and filtration kits;
- 2) Screw off the caps(17) counterclockwise with the special key (19) or coin;
- 3) Remove and clean the filters(16), then reinstall them;
- 4) Tighten the caps clockwise with the special key or coin. Turn counter-clockwise the stoppers with the hex wrench to open the check valve and filtration kits.

清理说明

适用于所有加工处理过的表面:
以中性肥皂水清洗镀层表面,再以干净的软布彻底擦干整个表面,许多清洁剂,比如氨水、去污粉及洁厕灵等,会对电镀表面造成伤害,切忌使用。

有腐蚀性的清洁剂或溶剂不可用于科勒牌的水龙头及其附件上。

CLEANING INSTRUCTIONS

All Finishes: Clean the finish with mild soap and warm water. Wipe entire surface completely dry with clean soft cloth. Many cleaners may contain chemicals, such as ammonia, chlorine, toilet cleaner etc. which could adversely affect the finish and are not recommended for cleaning.

Do not use abrasive cleaners or solvents on Kohler faucets and fittings.

16294T 恒温阀体

