

MODEL	CAPACITY L [GAL]	WEIGHT KG [LBS]	HEIGHT MM [IN]	LENGTH MM [IN]	EMERGENCY VENT (A) INNER / SECONDARY [IN]
230-275kW	1786 L [472 GAL]	911 KG [2009 LBS]	762 MM [30 IN]	4094 MM [161.2 IN]	4 / 4
300kW	2070 L [546 GAL]	939 KG [2070 LBS]	838.2 MM [33 IN]	4094 MM [161.2 IN]	4 / 5

THIS IS AN AUTOMATED TABLE. ALL CHANGES TO THIS TABLE MUST BE MADE IN THE FAMILY TABLE OF THE GENERIC MODEL.

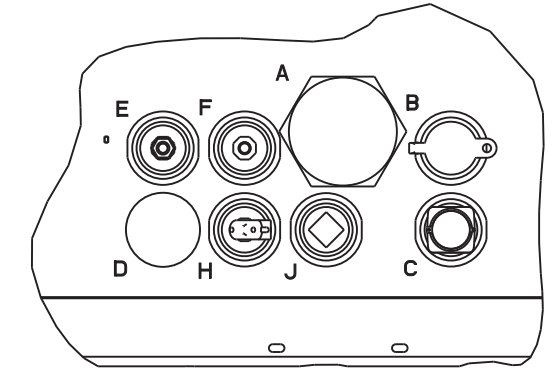

DETAIL A
SCALE 0.200

- TANK FITTINGS:**
- A. EMERGENCY VENT FITTING PER NFPA 30 WITH VENT CAPS (QTY 2).
 - B. 2" NPT FUEL FILL FITTING WITH LOCKABLE CAP AND 2" RISER.
 - C. 2" NPT FUEL LEVEL GAUGE FITTING WITH DIRECT READING MECHANICAL GAUGE.
 - D. 2" NPT NORMAL VENT FITTING WITH MUSHROOM VENT CAP AND 5" RISER.
 - E. 2" NPT FITTING FOR REMOVABLE ENGINE SUPPLY DIP TUBE (3/8" NPT FEMALE WITH CHECK VALVE).
 - F. 2" NPT FITTING FOR REMOVABLE FUEL RETURN DIP TUBE (3/8" NPT FEMALE).
 - H. 2" NPT FOR LOW LEVEL SWITCH (SET AT 50% FULL, SILICONE PACKED).
 - J. 2" NPT ADDITIONAL FITTING FOR OPTIONAL ACCESSORY (INSTALL STEEL 2" NPT PIPE PLUG).
 - M. 1/2" NPT BASIN DRAIN (INSTALL STEEL 1/2" NPT PIPE PLUG).
 - N. 1/2" NPT FOR FUEL IN BASIN SWITCH (INSTALL STEEL 1/2" NPT PIPE PLUG).

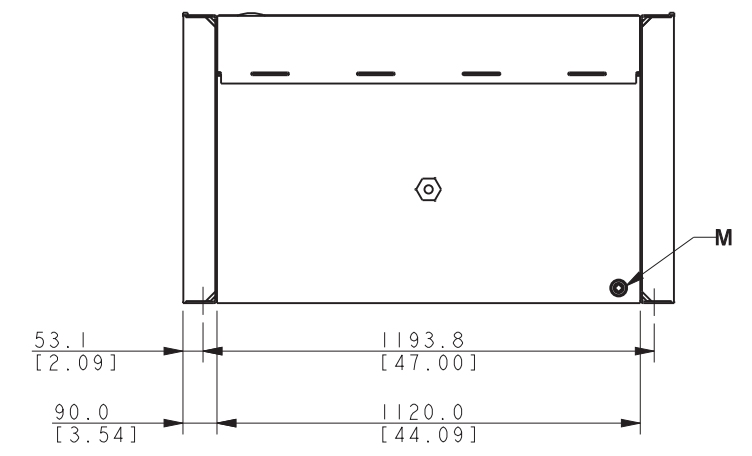
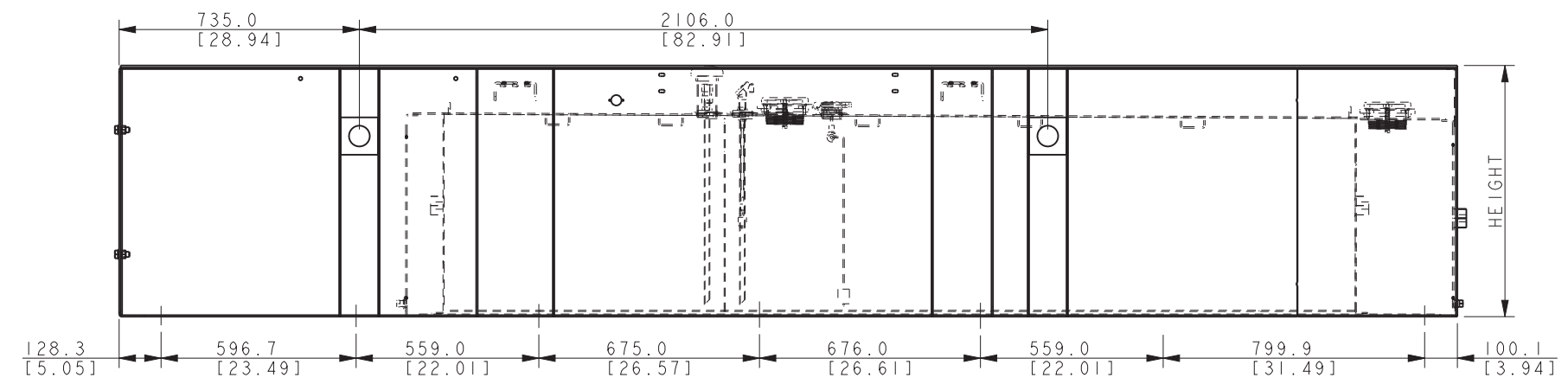
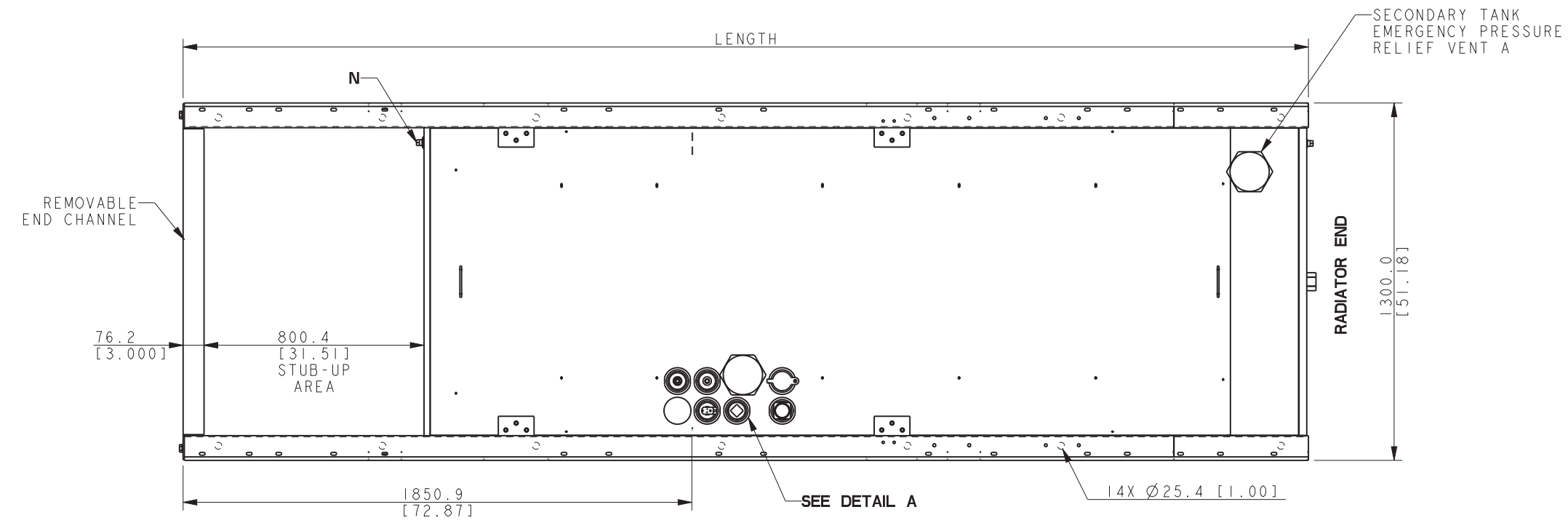

NOTE:
FOR FURTHER TANK DETAIL
SEE INDIVIDUAL DRAWINGS.

230-300KW
JOHN DEERE TIER III
STANDARD CODE TANK

REV	DATE	ON COMPOSITE DWGS. SEE PART NO. FOR REVISION LEVEL	BY	UNLESS OTHERWISE SPECIFIED - 1) DIMENSIONS ARE IN MILLIMETERS 2) TOLERANCES ARE:
A	11-17-09	SEE SHEET 2 OF 2. (C-4) 14X Ø25.4 WAS 12X (A-6) 675.0 AND 676.0 ADDED. [88481]	GFR	X.XX ± 0.25 X.X ± 1.0 ANGLES ± 0° 30'
B	10-7-10	(D-8) STANDARD TANK TABLE ADDED [90099-6]	RJS	SURFACE FINISH MAX. THIRD ANGLE PROJECTION
C	12-2-11	VIEWS UPDATED [92417-5]	SDS	
D	5-8-12	SEE SHEETS 2 & 3, SHEET 3 ADDED [CT13297]	JB2	
E	10-21-15	SEE SHEET 3 OF 3. [CT128239]	GFR	
F	11-17-17	(D-5) 546 GAL., SECONDARY VENT 5" WAS 4", TABLE UPDATED [CT181456]	JB2	
G	7-31-19	SEE SHEET 2 [CT197533]	PAS	

DIMENSIONS IN [] ARE ENGLISH EQUIVALENTS.

KOHLER CO. METRIC PRO-E

POWER SYSTEMS, KOHLER, WI 53044 U.S.A.
THIS DRAWING IN DESIGN AND DETAIL IS KOHLER CO. PROPERTY AND MUST NOT BE USED EXCEPT IN CONNECTION WITH KOHLER CO. WORK. ALL RIGHTS OF DESIGN OR INVENTION ARE RESERVED.

TITLE: **DIMENSION PRINT**

SCALE 0.10 CAD NO. SHEET 1 of 3
ADV-7645 D

MODEL	CAPACITY L [GAL]	WEIGHT KG [LBS]	HEIGHT MM [IN]	LENGTH MM [IN]	E - VENTS SIZE (QTY)
230-300kW	2102 L [555 GAL]	1242 KG [2738 LBS]	635 MM [25 IN]	5008 MM [197.2 IN]	5 (2)
230-275kW	3573 L [944 GAL]	1851 KG [4081 LBS]	914.4 MM [36 IN]	5325 MM [209.7 IN]	5 (2)

THIS IS AN AUTOMATED TABLE. ALL CHANGES TO THIS TABLE MUST BE MADE IN THE FAMILY TABLE OF THE GENERIC MODEL.

- TANK FITTINGS:**
- A. EMERGENCY VENT FITTING PER NFPA 30 WITH VENT CAPS (QTY 2).
 - B. 2" NPT FUEL FILL FITTING WITH LOCKABLE CAP AND 2" RISER.
 - C. 2" NPT FUEL LEVEL GAUGE FITTING WITH DIRECT READING MECHANICAL GAUGE.
 - D. 2" NPT NORMAL VENT FITTING WITH MUSHROOM VENT CAP AND 5" RISER.
 - E. 2" NPT FITTING FOR REMOVABLE ENGINE SUPPLY DIP TUBE (3/8" NPT FEMALE WITH CHECK VALVE).
 - F. 2" NPT FITTING FOR REMOVABLE FUEL RETURN DIP TUBE (3/8" NPT FEMALE).
 - H. 2" NPT FOR LOW LEVEL SWITCH (SET AT 50% FULL, SILICONE PACKED).
 - J. 2" NPT ADDITIONAL FITTING FOR OPTIONAL ACCESSORY (INSTALL STEEL 2" NPT PIPE PLUG).
 - M. 2" NPT BASIN DRAIN (INSTALL STEEL 2" NPT PIPE PLUG).
 - N. 2" NPT FOR FUEL IN BASIN SWITCH.
 - P. 2" NPT ADDITIONAL FITTING FOR OPTIONAL ACCESSORY (INSTALL STEEL 2" NPT PIPE PLUG).

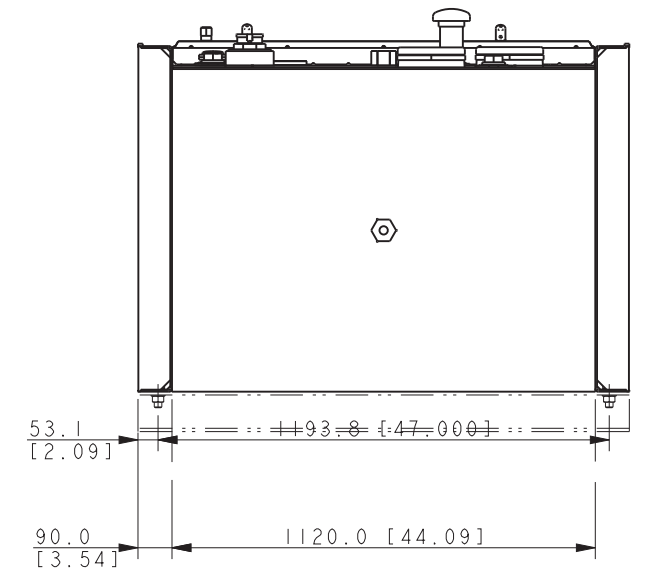
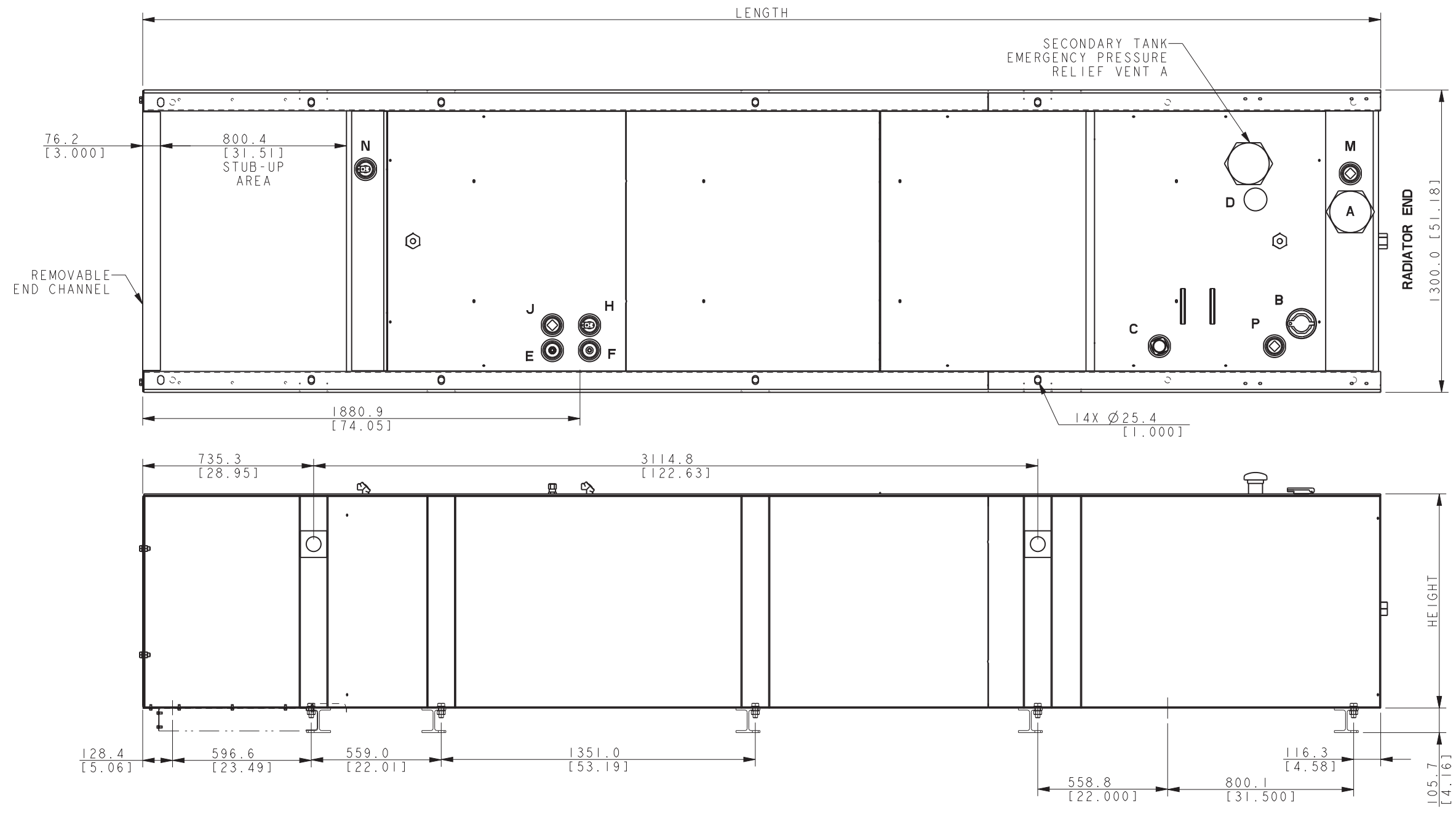

NOTE:
FOR FURTHER TANK DETAIL
SEE INDIVIDUAL DRAWINGS.

**230-300KW
JOHN DEERE TIER III
STATE CODE TANK**

REV	DATE	ON COMPOSITE DWGS. SEE PART NO. FOR REVISION LEVEL	BY	UNLESS OTHERWISE SPECIFIED - 1) DIMENSIONS ARE IN MILLIMETERS 2) TOLERANCES ARE:
A	11-18-09	SEE SHEET 1 OF 2. (D-7) 800.4 ADDED. [88481]	GFR	X.XX ± 0.25
B	10-7-10	(D-8) STATE TANK TABLE ADDED [90099-6]	RJS	X.X ± 1.0
C	12-2-11	VIEWS UPDATED [92417-5]	SDS	X ANGLES ± 0° 30'
D	5-8-12	SEE SHEET 3, (D-8) 300 KW MOVED TO SHEET 3, (D-3) FITTING NOTES REVISED [CT13297]	JB2	THIRD ANGLE PROJECTION
E	10-21-15	SEE SHEET 3 OF 3. [CT128239]	GFR	APPROVALS
F	11-17-17	SEE SHEET 1 [CT181456]	JB2	DATE
G	7-31-19	(D-5) EMERGENCY VENTS FOR 555 GAL: 5" WAS 4" [CT197533]	PAS	CHECKED DEF 10-27-08 APPROVED DEF 10-27-08

DIMENSIONS IN [] ARE ENGLISH EQUIVALENTS.

KOHLER CO. METRIC PRO-E
POWER SYSTEMS, KOHLER, WI 53044 U.S.A.
THIS DRAWING IN DESIGN AND DETAIL IS KOHLER CO. PROPERTY AND MUST NOT BE USED EXCEPT IN CONNECTION WITH KOHLER CO. WORK. ALL RIGHTS OF DESIGN OR INVENTION ARE RESERVED.

TITLE: DIMENSION PRINT

SCALE 0.10 CAD NO. SHEET 2 of 3
DWG NO. **ADV-7645**

MODEL	CAPACITY L [GAL]	WEIGHT KG [LBS]	HEIGHT MM [IN]	LENGTH MM [IN]	E - VENTS SIZE (QTY)
300kW	4066 L [1074 GAL]	1809 KG [3989 LBS]	914.4 MM [36 IN]	5588 MM [220.0 IN]	6 (2)

THIS IS AN AUTOMATED TABLE. ALL CHANGES TO THIS TABLE MUST BE MADE IN THE FAMILY TABLE OF THE GENERIC MODEL.

- TANK FITTINGS:**
- A. EMERGENCY VENT FITTING PER NFPA 30 WITH VENT CAPS (QTY 2).
 - B. 2" NPT FUEL FILL FITTING WITH LOCKABLE CAP AND 2" RISER.
 - C. 2" NPT FUEL LEVEL GAUGE FITTING WITH DIRECT READING MECHANICAL GAUGE.
 - D. 2" NPT NORMAL VENT FITTING WITH MUSHROOM VENT CAP AND 5" RISER.
 - E. 2" NPT FITTING FOR REMOVABLE ENGINE SUPPLY DIP TUBE (3/8" NPT FEMALE WITH CHECK VALVE).
 - F. 2" NPT FITTING FOR REMOVABLE FUEL RETURN DIP TUBE (3/8" NPT FEMALE).
 - H. 2" NPT FOR FUEL LEVEL SENDER.
 - J. 2" NPT ADDITIONAL FITTING FOR OPTIONAL ACCESSORY (INSTALL STEEL 2" NPT PIPE PLUG).
 - M. 2" NPT BASIN DRAIN (INSTALL STEEL 2" NPT PIPE PLUG).
 - N. 2" NPT FOR FUEL IN BASIN SWITCH.
 - P. 2" NPT ADDITIONAL FITTING FOR OPTIONAL ACCESSORY (INSTALL STEEL 2" NPT PIPE PLUG).
 - T. 2" NPT ADDITIONAL FITTING FOR OPTIONAL ACCESSORY (INSTALL STEEL 2" NPT PIPE PLUG).

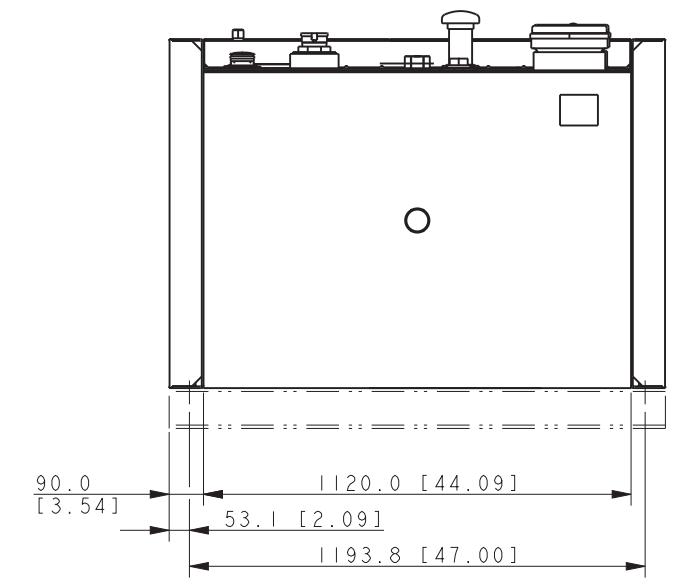
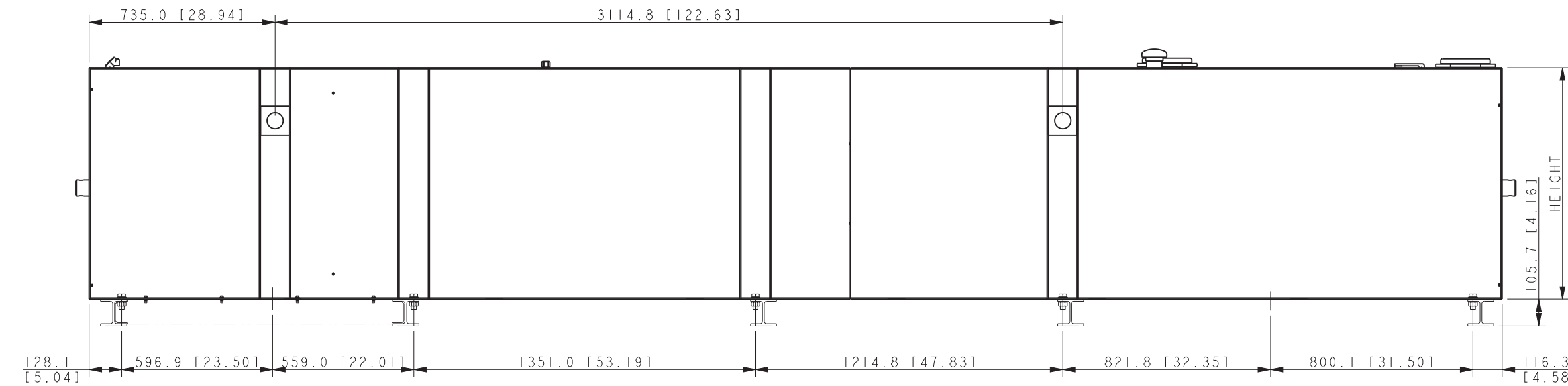
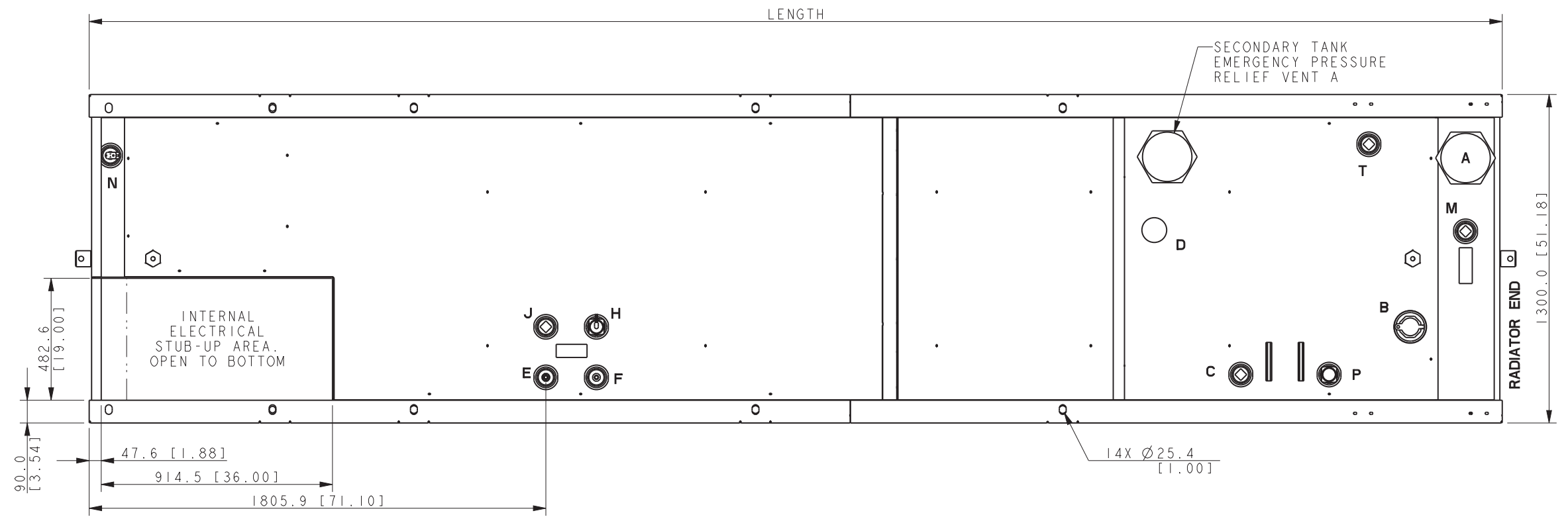

NOTE:
FOR FURTHER TANK DETAIL
SEE INDIVIDUAL DRAWINGS.

**300KW
JOHN DEERE TIER III
STATE CODE TANK**

REV	DATE	ON COMPOSITE DWGS. SEE PART NO. FOR REVISION LEVEL	BY
D	5-8-12	SEE SHEET 2,(D-2) FITTING NOTES REVISED [CT13297]	JB2
E	10-21-15	(D-5) E-VENT: 6 WAS 5. [CT128239]	GFR
F	11-17-17	SEE SHEET 1 [CT181456]	JB2
G	7-31-19	SEE SHEET 2 [CT197533]	PAS

UNLESS OTHERWISE SPECIFIED -
1) DIMENSIONS ARE IN MILLIMETERS
2) TOLERANCES ARE:
X.XX ± 0.25
X.X ± 1.0
X ± 1.5
ANGLES ± 0° 30' MAX.

THIRD ANGLE PROJECTION

APPROVALS	DATE
DRAWN JB2	5-8-12
CHECKED DCF	5-8-12
APPROVED SLJ	5-8-12

DIMENSIONS IN [] ARE ENGLISH EQUIVALENTS.

KOHLER CO. METRIC PRO-E

POWER SYSTEMS, KOHLER, WI 53044 U.S.A.

THIS DRAWING IN DESIGN AND DETAIL IS KOHLER CO. PROPERTY AND MUST NOT BE USED EXCEPT IN CONNECTION WITH KOHLER CO. WORK. ALL RIGHTS OF DESIGN OR INVENTION ARE RESERVED.

TITLE: **PRINT, DIMENSION**

SCALE 0.10 CAD NO. SHEET 3 of 3

DWG NO. **ADV-7645**