

**Standard & Memory
models covered**

mira

**ADVANCE
THERMOSTATIC**

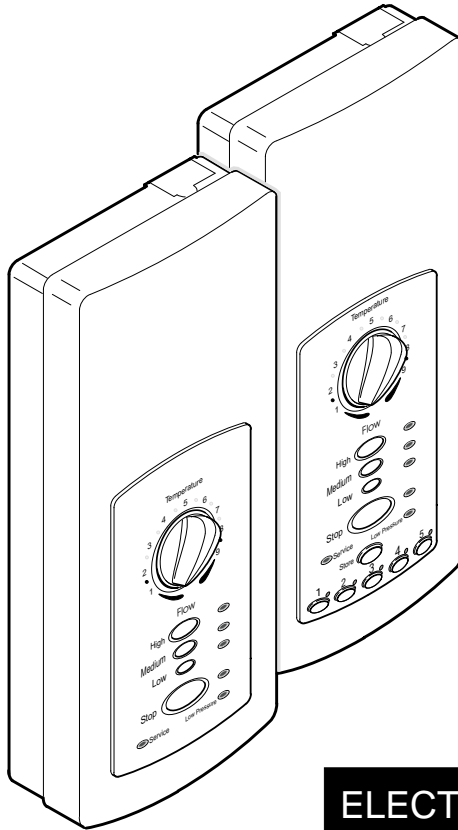

ELECTRIC SHOWERS

Installation

Operation &

Maintenance Guide

THESE INSTRUCTIONS ARE TO BE LEFT WITH THE USER

Contents

	Page
Introduction	3
Important Safety Information	4
Pack Contents Checklist.....	7
Dimensions	8
Wiring Diagram	10
Specifications	11
Installation Requirements.....	12
Installation	16
Commissioning.....	21
Operation.....	23
Fault Diagnosis.....	29
Maintenance	36
Maximum Temperature Setting	42
Spare Parts	43
Guarantee, Customer Care Policy, and How to contact us	Back cover

Thank you for purchasing a quality Mira product. To exploit the full potential of your new shower, please take time to read this guide thoroughly, having done so, keep it handy for future reference.

The Mira Advance is a high performance electric shower, which provides thermostatic temperature control. The Mira Advance compensates for pressure, temperature and voltage changes to achieve a very accurate temperature whilst showering. Separate push-button controls allow the user to select three independent flow settings. The Mira Advance features as standard, a safe 'maximum temperature setting', but also has a special feature which allows the shower temperature to be limited to 43°C.

A memory control version is available which allows the user to preset five choices of flow level and temperature, which can be recalled on demand.

For healthcare or special need requirements, refer to "Maximum Temperature Setting".

Mira Advance covered by this guide:

Mira Advance (standard control) 8.7 kW 240 Volts, 8.0 kW 230 Volts

Mira Advance (standard control) 9.8 kW 240 Volts, 9.0 kW 230 Volts

Mira Advance (memory control) 8.7 kW 240 Volts, 8.0 kW 230 Volts

Mira Advance (memory control) 9.8 kW 240 Volts, 9.0 kW 230 Volts

If you experience any difficulty with the installation or operation of your new Mira Advance, then please refer to **Fault Diagnosis**, before contacting Caradon Plumbing Solutions. Our telephone and fax numbers can be found on the back cover of this guide.

1. Warning!

- 1.1. Products manufactured by us are safe and without risk provided they are installed, used and maintained in good working order in accordance with our instructions and recommendations.
- 1.2. THIS MIRA ADVANCE **MUST** BE EARTHED.
- 1.3. In accordance with the current edition of 'The Plugs and Sockets etc. (Safety) Regulations in force at the time of installation, this Mira Advance is intended to be permanently connected to the fixed electrical wiring of the mains system.
- 1.4. **DO NOT** twist the individual cable cores of the live and neutral conductors, as this will prevent them from entering the terminal block.
- 1.5. Make sure that any pipework that could become frozen is properly insulated.
- 1.6. **DO NOT** operate this Mira Advance if it is frozen. Allow the Mira Advance to thaw before using again. The shower unit must not be fitted where it may be exposed to freezing conditions.
- 1.7. If water leaks from the pressure relief valve, maintenance will be required before the Mira Advance can be safely used.
- 1.8. **DO NOT** fit any form of outlet flow control as the outlet acts as a vent for the tank body. Only Mira recommended outlet fittings should be used.
- 1.9. There are no user serviceable components beneath the cover of the Mira Advance. Only a competent tradesperson should remove the cover.
- 1.10. If any of the following conditions occur, isolate the electricity and water supplies and refer to "**To contact us**", on the back page of this guide.
 - 1.10.1. If the cover is not correctly fitted and water has entered the Mira Advance case.
 - 1.10.2. If the case is damaged.
 - 1.10.3. If the Mira Advance begins to make an odd noise, smell or smoke.
 - 1.10.4. If the Mira Advance shows signs of a distinct change in performance, indicating a need for maintenance.
 - 1.10.5. If the Mira Advance is frozen.

- 1.11. Isolate the electrical and water supply before removing the cover.
- 1.12. Mains connections are exposed when the cover is removed.
- 1.13. Refer to the wiring diagram before making any electrical connections.
- 1.14. Ensure all electrical connections are tight, to prevent overheating.

2. Caution!

- 2.1. **Read all of these instructions and retain this guide for later use.**
- 2.2. Pass on this guide in the event of change of ownership of the installation site.
- 2.3. Follow all warnings, cautions and instructions contained in this guide, and on or inside the Mira Advance.
- 2.4. The electrical installation must comply with the “Requirements for Electrical Installations” commonly referred to as the IEE Wiring Regulations, or any particular regulations and practices, specified by the local electricity supply company in force at the time of installation. The installation should be carried out by an electrician or contractor who is registered, or is a member of, an association such as:
 - 2.4.1. National Inspection Council for Electrical Installation and Contracting (NICEIC), throughout the UK, Tel: 0171 582 7746.
 - 2.4.2. The Electrical Contractors Association (ECA), England and Wales, Tel: 0171 229 1266.
 - 2.4.3. The Electrical Contractors Association of Scotland (ECAS), Tel: 0131 445 5577.
- 2.5. This is a high power unit; it is essential to contact your electricity supply company to ensure that the electricity supply is adequate for the purpose.
- 2.6. The plumbing installation must comply with the requirements of UK Water Regulations/Bylaws (Scotland), Building Regulations or any particular regulations and practices, specified by the local water company or water undertakers. The installation should be carried out by a plumber or contractor who is registered, or is a member of, an association such as:
 - 2.6.1. Institute of Plumbing (IOP), throughout the UK, Tel: 01708 472791.
 - 2.6.2. National Association of Plumbing, Heating and Mechanical Services Contractors (NAPH & MSC), England and Wales, Tel: 01203 470626.
 - 2.6.3. Scottish and Northern Ireland Plumbing Employers' Federation (SNIPEF), Scotland and Northern Ireland, Tel: 0131 225 2255.

- 2.7.** Anyone who may have difficulty understanding or operating the controls of any shower should be attended whilst showering. Particular consideration should be given to the young, the elderly, the infirm, or anyone inexperienced in the correct operation of the controls.

- 2.8.** When this Mira Advance has reached the end of its serviceable life, it should be disposed of in a safe manner, in accordance with current local authority recycling, or waste disposal policy.

Pack Contents Checklist

☑ Tick the appropriate boxes to familiarize yourself with the part names and to confirm that the parts are included.

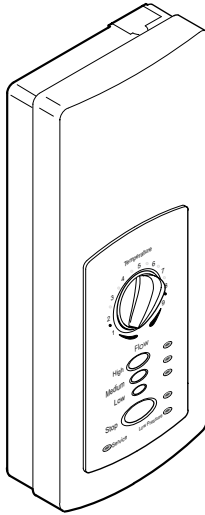

or

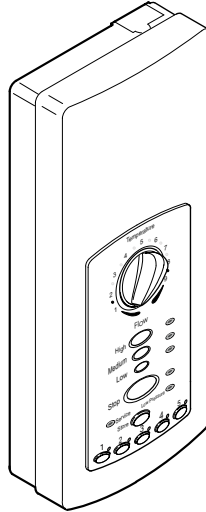

1 x Mira Advance

2 x Wall Screws

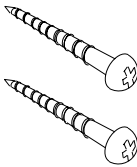

1 x Earth Sleeve

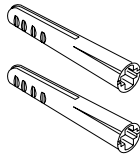

1 x Wall Plugs



1 x Tap Connector Adaptor
(for fitting to existing tap connector)



1 x Olive

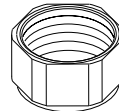

1 x Compression Nut

2. Documentation

1 x Installation, Operation and Maintenance Guide

1 x Customer Support Brochure

1. Mira Advance

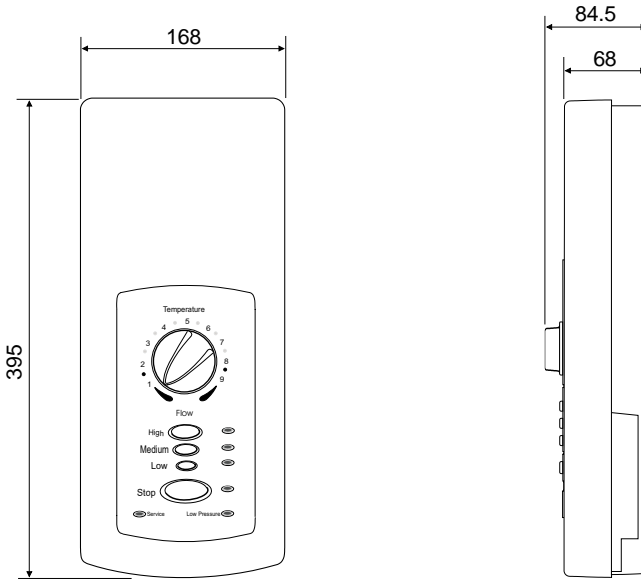

Standard Model

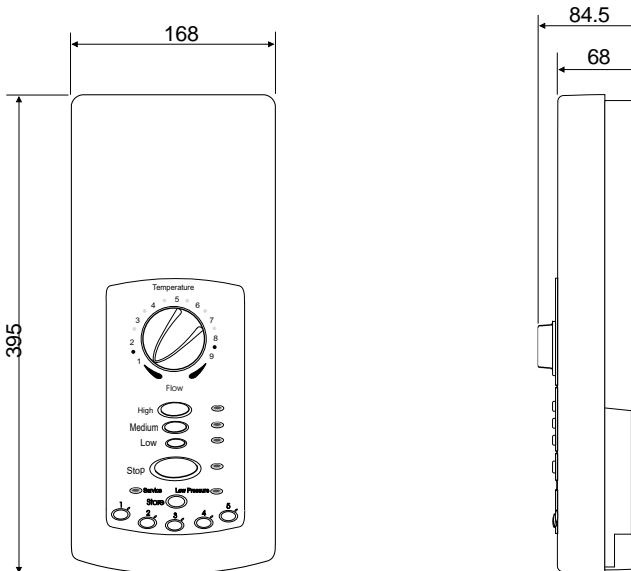

Memory Model

All dimensions are nominal and in millimetres.

2. Water and Cable Entry Points

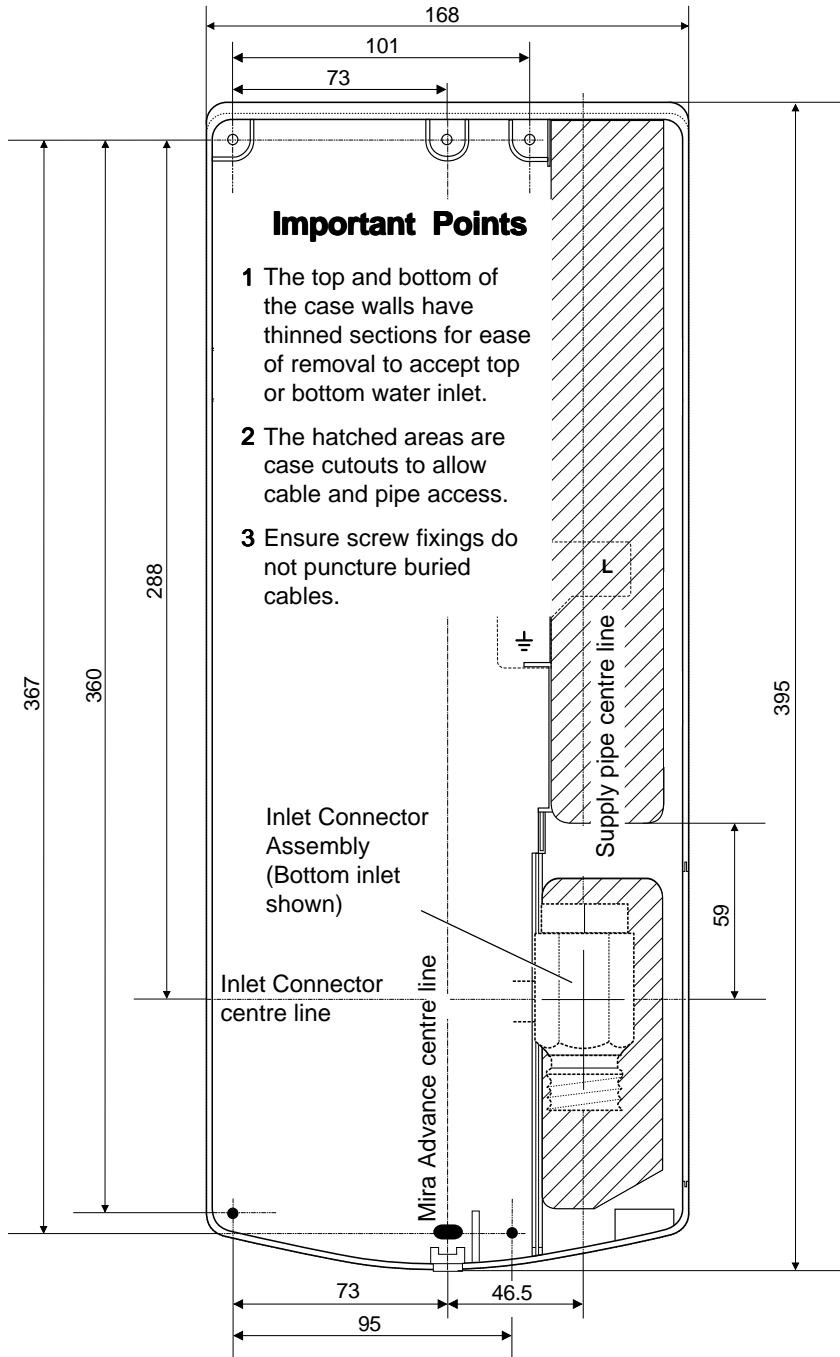

All dimensions are nominal and in millimetres.

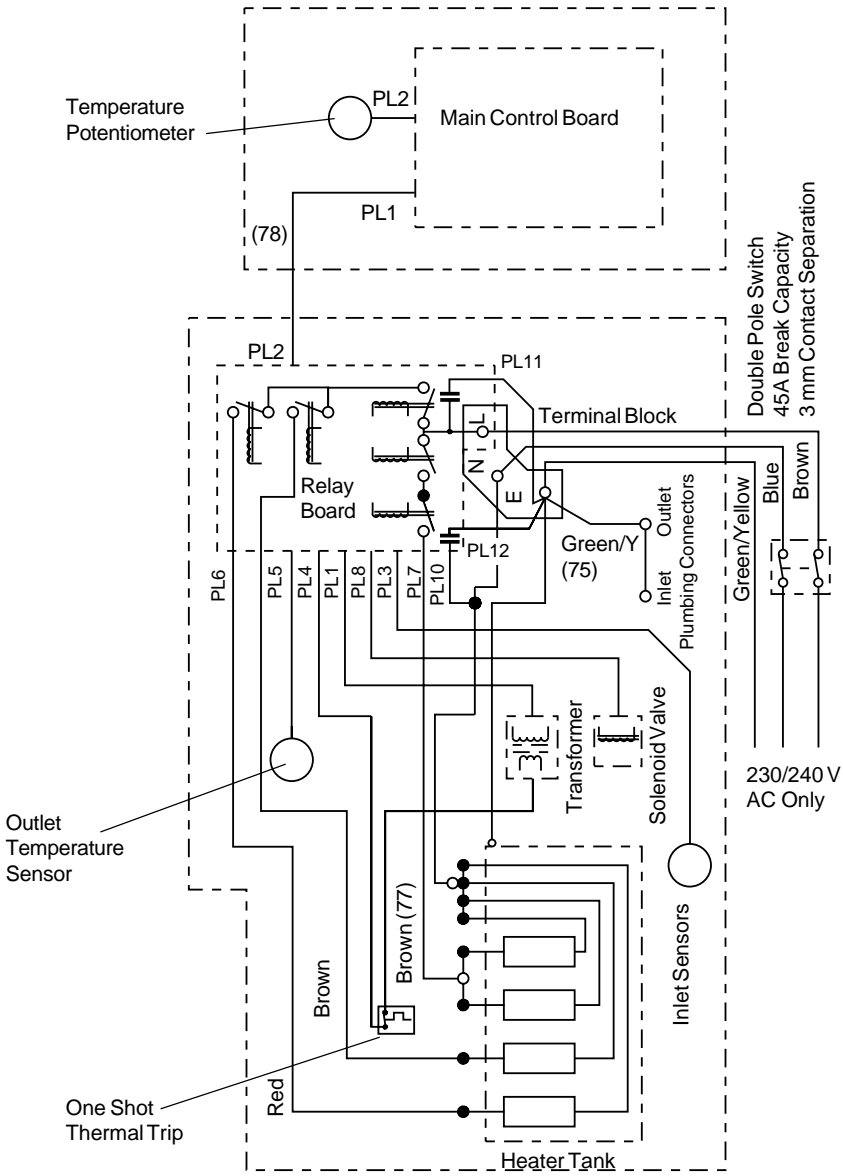

1. Plumbing

- 1.1. The inlet connector assembly incorporates an inlet filter, which swivels to allow these entry positions, top, top back, bottom and bottom back inlet.
- 1.2. The outlet terminates with a 1/2" BSP male thread for connection to a Mira flexible shower hose.
- 1.3. A maintained pressure of at least **1 bar** is recommended for the product up to a maximum static pressure of **10 bar**.

Thermostatic performance will be maintained down to **0.5 bar** maintained pressure. However, this will result in reduced power and therefore reduced flow.

- 1.4. The Mira Advance will provide satisfactory performance with incoming water supply temperatures between 2°– 28°C.
- 1.5. Maximum ambient temperature for the Mira Advance whilst in use is 30°C.

2. Electrical

- 2.1. Mira Advance supply fuse - 8.7 kW 40 Amp
 9.8 kW 45 Amp
- 2.2. The terminal block will not accept cable larger than 16 mm².
- 2.3. The Mira Advance will provide satisfactory performance with an incoming electricity supply voltage of 230 V ± 10%.

3. Standards and Approvals

- 3.1. The Mira Advance has been designed to comply with the requirements of the British Electrotechnical Approvals Board (BEAB) and the requirements of UK Water Regulations/Bylaws (Scotland).
- 3.2. This Mira Advance complies with all relevant directives for CE marking.

1. Plumbing

Read the section "**Important Safety Information**" first.

- 1.1. A maintained pressure of at least **1 bar** is recommended for the product up to a maximum static pressure of **10 bar**.

Thermostatic performance will be maintained down to **0.5 bar** maintained pressure. However, this will result in reduced power and therefore reduced flow.

- 1.2. The Mira Advance is suitable for installation within the shower area and must be positioned over a water catchment area with the controls at a convenient height for the user. The shower fitting should be positioned so that it discharges down the centre line of the bath, or across the opening of a shower cubicle, and must be directed away from the Mira Advance.

- 1.3. The Mira Advance is fitted with an inlet connector assembly that is designed to accept plumbing supplies from the top, bottom or back. The water supply can be fed with 15 mm pipe or 10 mm microbore pipe, suitably reduced into the inlet connector assembly. If 10 mm microbore is used, then an allowance for increased pressure loss must be made to ensure that the minimum maintained inlet pressure is achieved (see note above).

- 1.4. The Mira Advance must be fitted **ONTO** the finished wall surface i.e. on top of the tiles. **DO NOT** block the air ventilation gaps around the sides of the unit, either by tiling up to the sides of the unit or by using a sealant around the case (Small pillars moulded on to the back of the case allow air circulation). This Mira Advance is designed to be ventilated. Failure to do this may cause product failure (Refer to Figure 1).

- 1.5. Use only the inlet connector assembly supplied with the Mira Advance, do not use any other types of fitting.

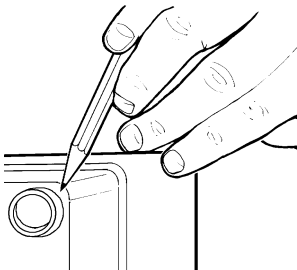

Figure 1

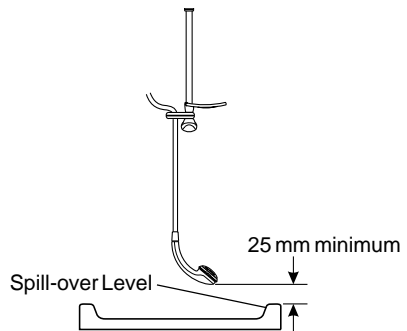

Figure 2

- 1.6. **Do not install the Mira Advance in a position where it may become frozen.** The shower unit must not be fitted where it may be exposed to freezing conditions. Do not operate the unit if suspected of being frozen.
- 1.7. When installing the inlet connector for back inlet supply (refer to **Installation**) connection, it is advisable to seal around the incoming mains-fed supply to prevent water ingress into the wall.
- 1.8. We recommend that a non-restrictive (free flowing) isolating valve is fitted in the cold water supply pipe to allow the complete maintenance of the Mira Sport. **Do not** use a valve with a loose washer plate (jumper) as this can lead to a build up of static pressures.
- 1.9. The Mira Advance is fitted with a 1/2" BSP male outlet thread, to accept a Mira shower hose.
- 1.10. Refrain from applying excessive force when making any connections. Always provide mechanical support when making the plumbing connections.
- 1.11. To avoid damage to the case when soldered fittings are used, pre-solder the pipework and fittings before connecting them to the inlet connector assembly.

Note! Supply pipework **MUST** be flushed to clear debris before connecting the Mira Advance. **Debris will reduce the performance of the unit.**

- 1.12. When installed in very hard water areas (above 200 ppm temporary hardness) your installer may advise the installation of a water treatment device, to reduce the effects of limescale formation. Mira Sport malfunction due to excessive limescale formation is not covered by the manufacturer's guarantee. Your local water company will be able to advise the hardness of water in your area.
- 1.13. A hose retaining ring is supplied to prevent the handset from dropping below the spillover level of the bath or shower, which could lead to contamination from backsiphonage (refer to Figure 2). The supplied hose retaining ring should meet the great majority of user requirements for shower installations with flexible outlet fittings. However, there will be occasions when the hose retaining ring will not provide a suitable solution. In these instances an **outlet** double checkvalve, e.g. the Mira DCV-H, **must** be fitted. The inclusion of the Mira DCV-H will increase the required supply pressure typically by 0.1 bar.
Double checkvalves, fitted in the inlet supply to the appliance, cause a pressure buildup, which could exceed the maximum static inlet pressure for the appliance.
- 1.14. Avoid layouts where the shower hose will be sharply kinked. This may reduce the life of the hose.

2. Electrical

Read the section "**Important Safety Information**" first.

- 2.1. The electrical installation must comply with the "Requirements for Electrical Installations" commonly referred to as the IEE Wiring Regulations, or any particular regulations and practices, specified by the local electricity supply company in force at the time of installation.
- 2.2. In a domestic installation, the rating of the electricity supply company fuse and the consumer unit must be adequate for the additional demand. As these Mira Advances are high power units, it is essential to contact your electricity supply company to ensure that the supply is adequate for the Mira Advance. Voltage drop due to local heavy demand will reduce the shower's performance.
- 2.3. The Mira Advance **must be earthed** by connecting the supply-cable earth conductor to the earth terminal.

Supplementary bonding: Within the bathroom or shower room, all accessible conductive parts of electrical equipment and extraneous conductive parts that are likely to introduce earth potential, must be electrically bonded to earth using a minimum cable size of 4.0 mm² if the cable is not mechanically protected (2.5 mm² if mechanically protected).

- 2.4. The minimum cable size (cross-sectional area) required is 6 mm² under normal conditions of installation.

Important! The shower circuit should be separated from other circuits by at least twice the diameter of the cable or conduit and it should not be run through thermally insulating material or in locations where the ambient temperature is likely to exceed 30 °C. If any of these conditions are unavoidable it is necessary to determine the cable size which will prevent damage to the cable caused by overheating.

- 2.5. Do not turn-on the electrical supply until the plumbing has been completed.
- 2.6. A separate, permanently connected supply must be taken from the consumer unit to the Mira Advance through a double-pole switch, which has at least 3 mm contact separation. The switch can be a ceiling mounted pull-cord type within the shower room or a wall mounted switch in an adjacent room.

The minimum cable size required is 6 mm². To minimise voltage drop, and thereby maximise performance, use the shortest possible cable route from the consumer unit to the Mira Advance.

2.7. A 30 mA RCD **MUST** be fitted. This may be part of the consumer unit or a separate unit.

Note! The terminal block will not accept cable larger than 16 mm².

2.8. **DO NOT** twist the individual cable cores of the live and neutral conductors, as this will prevent them from entering the terminal block.

2.9. **DO NOT** exert strain on the terminal block.

2.10. **DO NOT** turn-on the electrical supply until the plumbing has been completed.

Plumbing and Electrical Schematic Diagram

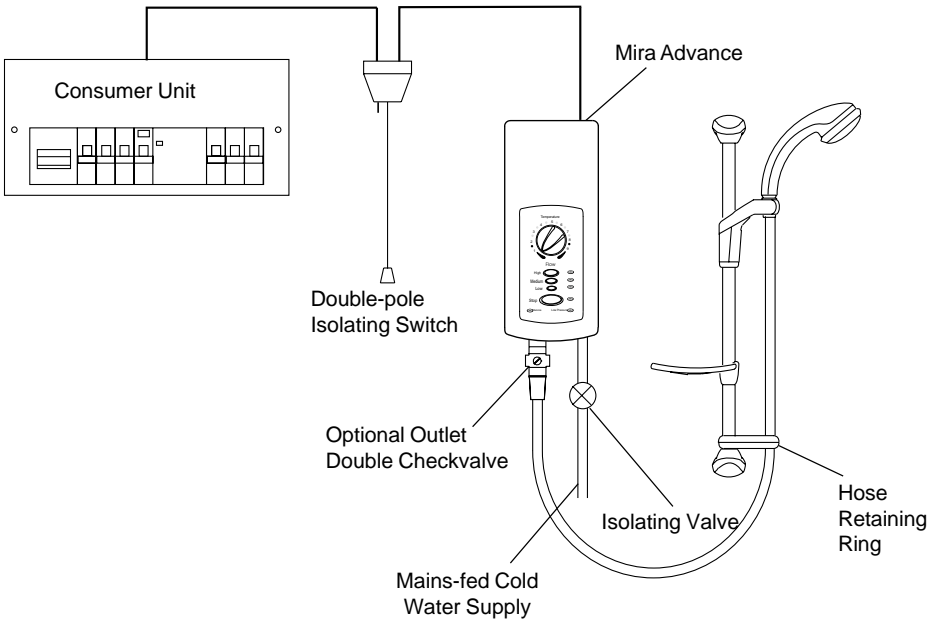

Figure 3



1. Mira Advance

Read the section "**Important Safety Information**" first.

WARNING! Isolate the electrical and water supplies before proceeding with the installation of the Mira Advance.

Note! Bottom inlet is illustrated for clarity in these instructions.

1.1. To remove the Mira Advance case remove the screw at the bottom of the case.

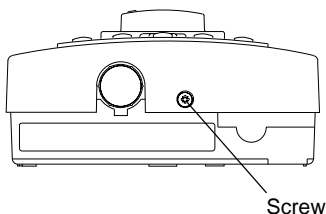

1.2. Pull the bottom of the Mira Advance cover outwards and upwards off the case.

1.3. Slide out the inlet shield, located over the inlet connector assembly.

1.4. Unscrew the transit sealing caps from the inlet and outlet of the Mira Advance.

1.5. When installing the Mira Advance with concealed water and electrical supplies refer to, "**Dimensions: Water and cable entry points**".

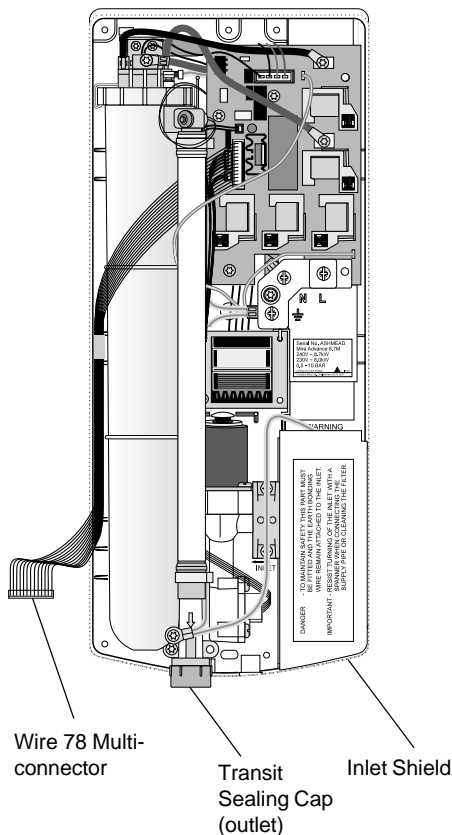

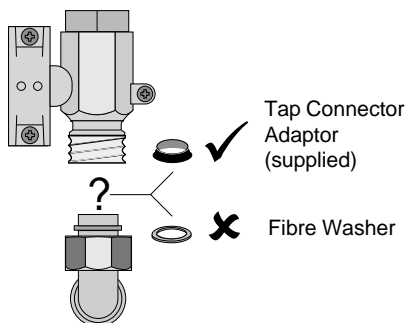
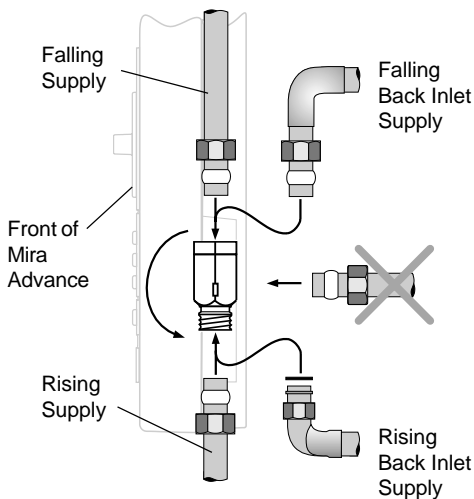
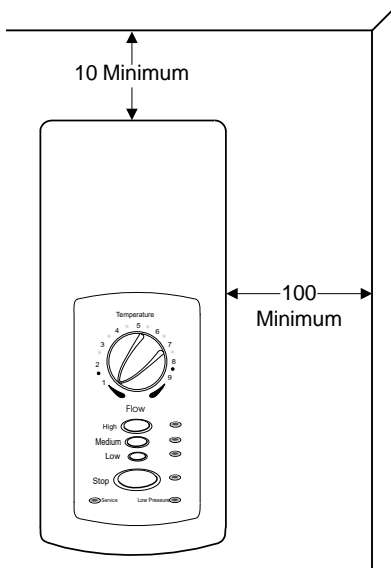

- 1.6. When deciding the position of the Mira Advance on the wall:
 - allow 100 mm minimum clearance to the right hand side of the case, to provide unrestricted access to the inlet connector, for installation and future maintenance.
 - allow 10 mm minimum clearance from the top of the case to allow the cover to be removed.
- 1.7. Determine whether the cold water and cable supplies will be top (falling), bottom (rising), or back inlet to the Mira Advance.
- 1.8. Swivel the inlet connector assembly to suit (not directly back into the wall). Avoid trapping the green earth bonding wire.
- 1.9. Remove as appropriate, the thinned sections in the Mira Advance case, to allow the pipe and cable to enter the product.
- 1.10. **Install the mains-fed cold water supply pipe**

The Mira Advance can be connected to either a compression fitting (supplied) or a tap connector (not supplied).

If upgrading from other Mira Advances that use a tap connector, then the tap connector adaptor can be used in place of the fibre washer. This allows the tap connector to be used in conjunction with the compression fitting of the product (see diagram).

For back inlet supplies, the cold water pipe must emerge from the walls surface 'square' to prevent straining the inlet connector clamp bracket. See diagram for options.

DO NOT connect directly back into the wall.

- 1.11. Thoroughly flush the mains-fed cold water supply pipe. The supply must be clean and free from debris BEFORE connecting the Mira Advance.**

Note! Debris will reduce the performance of the unit.

- 1.12.** Avoiding buried cables and pipes, choose one of the upper fixing holes which will allow the Mira Advance to be firmly fixed to the wall structure, and drill through the thinned hole section in the back of the case.
- 1.13.** Offer the Mira Advance up to the wall and temporarily connect the mains-fed cold water supply pipe. Mark through the casing the position of the upper and lower holes. Remove the Mira Advance from the wall before drilling. This will prevent debris from entering the Mira Advance.
- 1.14.** Drill and suitably plug the two fixing holes. Secure the Mira Advance to the wall with the screws provided. Alternative fixings (not supplied) may be necessary for some wall structures.
- 1.15.** Make the connection to the mains-fed cold water supply pipe. Hold a wrench across the flats of the inlet connector assembly to prevent damage to the connector, whilst tightening the compression nut. Turn on the water supply.

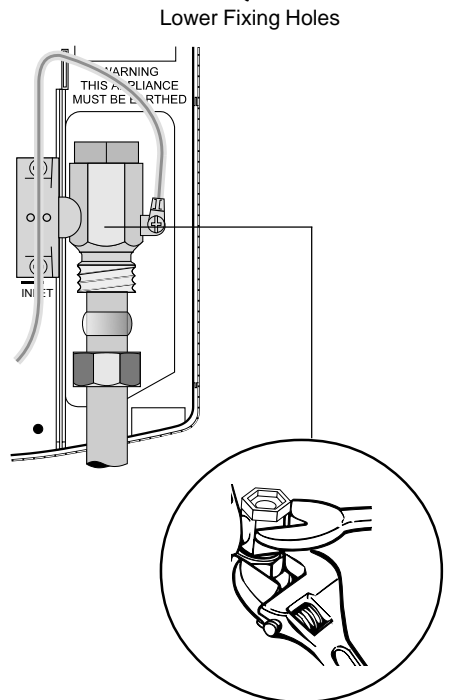
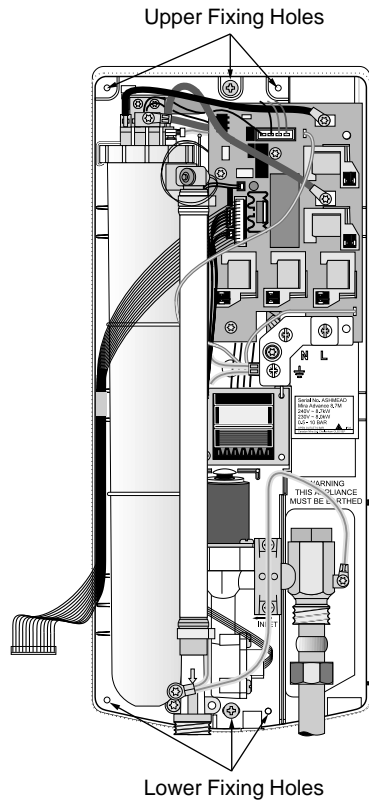

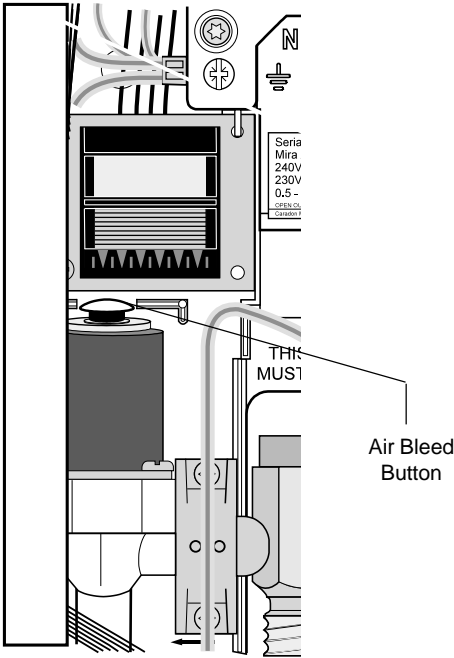

Priming the Mira Advance

Connect the shower hose to the Mira Advance and position the hose to discharge into the shower tray or bath waste outlet. Press the air bleed button, located on top of the flow valve, several times. This will allow the Mira Advance to fill with water and expel any entrapped air.

Note! Failure to prime the unit will severely effect performance.

Note! Water at full mains supply pressure will flow from the shower hose and a small amount of water will be discharged from under the air bleed button.

Caution! Once the air bleed button has been pressed ensure that is not fouled when released, otherwise water will continue to discharge from the bleed button.

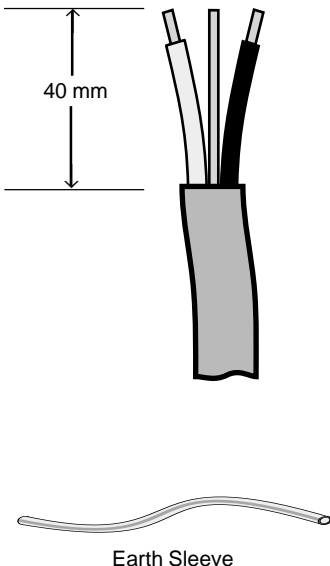

1.16. Bring the electrical supply cable into the case via one of the cable entry points, and offer up to the terminal block.

1.17. Strip back approximately 40 mm of the outer cable insulation. Fit the earth sleeve over the earth conductor.

Connect the conductors firmly into the terminal block (refer to wiring diagram). Ensure that the bare cores of each conductor are securely trapped **within** each conductor clamp.

L = Red Wire

N = Black Wire

≡ = Yellow/Green sleeved wire

1.18. Check that the earth bonding wire to the inlet connector assembly is tight. Ensure that the multi-connector lead is clear of the cover when it is refitted. Refit the inlet shield over the inlet connector assembly. If the Mira Advance has been installed with top inlet cable or water supplies, cut the top case insert to suit, and fit. Finally, re-tighten the screws of the terminal block.

1.19. Connect the wire 78 multi-connector lead from the relay board, in the Mira Advance, to the socket on the control PCB located in the cover. The multi-connector is a one way fit into the receiving socket on the control PCB. Ensure that the multi-connector is correctly orientated as illustrated. Ensure that the connector is fully pushed home.

1.20. Refit the cover by locating the top of the cover onto the location strip on the top of the case. Ensure that the wire 78 multi-connector lead is seated between the tank body and the left-hand side of the case.

1.21. Push the bottom of the cover against the case until it locates correctly. Install the screw and tighten.

1.22. Install the shower fittings, refer to the separate Installation, Operation and Maintenance Guide.

1.23. The high capacity spray plate illustrated in the guide is not supplied with this Mira Advance.

1.24. Now proceed to commission the Mira Advance. Refer to **"Commissioning"**.

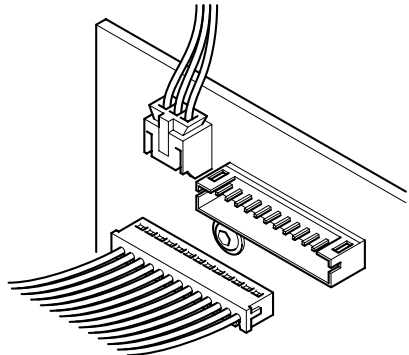
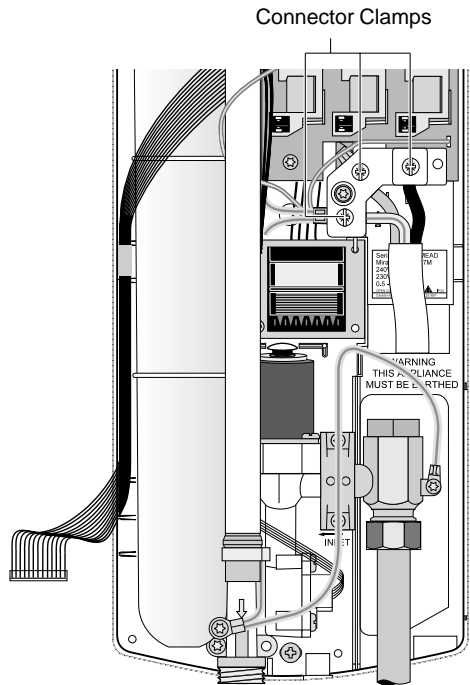

Ensure That The Connector Is Fully Pushed Home

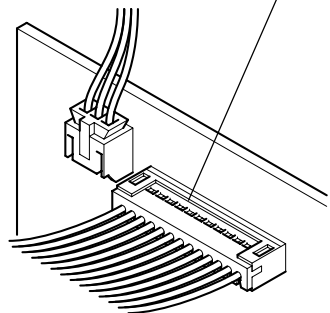

Read the section "**Important Safety Information**" first.

If you are unsure how electric showers work, please read through, "**Advice to users**" and "**Mira Advance**" before continuing.

1. Connect the flexible hose from the shower fitting to the outlet of the Mira Advance. Ensure that the hose seals are fitted, and that the handset is in the handset holder and aimed into the water catchment area.

Do not overtighten. Over-tightening the flexible hose will shorten its life.

2. Turn the '**TEMPERATURE**' control knob to **full cold**. The control knob operates through approximately $\frac{3}{4}$ of a turn from cold to hot and features a detent on the final travel to the cold only position.

3. Turn on the water supply fully at the isolating valve. Check that water is not leaking from the bottom of the case.

4. Switch on the electrical supply at the double-pole switch. The red indicator beside the '**STOP**' button will illuminate providing a visual indication that the electrical supply is connected.

5. Press the '**LOW**' flow button and observe the green indicator and the audible tone. Check that cold water flows freely from the shower within a few seconds. If a delay of more than 5 seconds is encountered, then it is likely that the Mira Advance has not been primed. Refer to "**Installation**".

Warning! Isolate the electrical supply as this step requires that the Mira Advance cover be removed. Should the Mira Advance still not function then refer to "**Fault Diagnosis**".

6. Turn the '**TEMPERATURE**' control knob to position '**5**' and allow the Mira Advance to operate for 2 minutes. During this period the Mira Advance will calibrate itself to the site conditions.

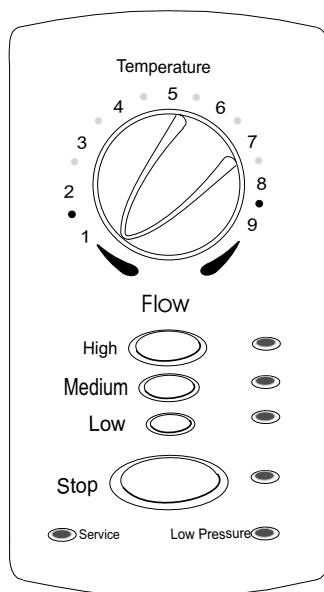

7. **Press** the '**MEDIUM**' flow button and observe an increase in flow of water, the green indicator and the audible tone. Allow the Mira Advance to operate for 2 minutes.
8. **Press** the '**HIGH**' flow button and observe an increase in flow of water, the green indicator and the audible tone. Allow the Mira Advance to operate for 2 minutes.
9. **Turn** the '**TEMPERATURE**' control to cold and then **slowly** turn the '**TEMPERATURE**' control from cold through to position **number 6**, which is a typical showering temperature. If a satisfactory temperature cannot be achieved, then turn the '**TEMPERATURE**' control through to position **number 8**.

Note! Changing the temperature requires the staged power up and power down of individual heating elements. During this sequence the user may hear a number of audible 'clicks' from the relays.

10. **Press** the '**MEDIUM**' flow button. The flow of water will decrease, but the selected temperature will remain relatively constant.
11. **Press** the '**LOW**' flow button. The flow of water will decrease, but the selected temperature will remain relatively constant.

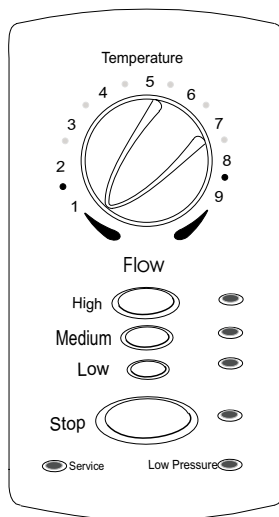

12. **Press** the '**STOP**' button and observe the red indicator and audible tone. **The Mira Advance will continue to run for a few seconds before shutting off. Audible 'clicks' will be heard.**

Note! To ensure the commissioning process is memorised by the Mira Advance the **STOP** button must be pressed before electrically isolating the Mira Advance.

Note! Water may continue to drip for a short time whilst the water drains out of the handset .

Note! High cold water mains supply pressures and high shower temperatures will cause a slight audible hissing sound to be heard from the Mira Advance whilst it is operating. This is quite normal and does not indicate that there is a fault with the Mira Advance.

1. Advice to Users

Read the section "**Important Safety Information**" first.

- 1.1. In the event that the Mira Advance fails to respond to any push-button instruction, or exhibits unusual performance characteristics during operation, **first** turn off the electrical supply by operating the pull-cord switch, **wait for a few moments for the Mira Advance to reset**, then turn on the pull-cord switch and operate the Mira Advance. If the problem still persists then refer to **Fault Diagnosis**.
- 1.2. Electric showers work by taking in cold water and passing it over the heating elements contained in the tank body of the shower Mira Advance.
- 1.3. The showering temperature is adjusted by turning the temperature control knob, which varies the flow of cold water across the elements. The slower the rate of flow, the warmer the water and vice versa. The holes in the spray plate of the shower handset should always be kept clean to maintain a consistent flow and stable shower temperatures.
- 1.4. A maintained pressure of at least **1 bar** is recommended for the product up to a maximum static pressure of **10 bar**.

Thermostatic performance will be maintained down to **0.5 bar** maintained pressure. However, this will result in reduced power and therefore reduced flow.

- 1.5. Seasonal changes in the temperature of the incoming cold water supply and mains electrical voltage, will mean that the **flow rate of water** at accustomed 'TEMPERATURE' control knob settings will vary as follows:

Summer: Due to the thermostatic response of the shower the flow from the Advance on medium/high flow setting in the summer may be lower than the flow in the autumn or spring.

Winter: Due to the thermostatic response of the shower the flow from the Advance on low/medium flow setting in the winter may be higher than the flow in the autumn or spring.

- 1.6. The Mira Advance monitors the following functions:
 - 1.6.1. The incoming cold water temperature.
 - 1.6.2. The outgoing shower temperature.
 - 1.6.3. The flow rate of water.
 - 1.6.4. The current user settings.

The Mira Advance then calculates the flow rate and power level, to keep the outgoing temperature constant. This mode of operation requires the staged power up and power down of individual heating elements. During this sequence the user may hear a number of audible 'clicks' and the flow rate may change.

1.7. Low Pressure Thermostatic Performance (below 1 bar maintained)

If the supply pressure falls below 1 bar maintained the unit may switch off elements to maintain the temperature. A reduced flow will be observed even though the user selected flow indication remains unchanged.

Restoration of the original pressure condition will not automatically restore the flow setting. This can be achieved (subject to restoration of adequate supply pressure) by manually reselecting the desired flow condition (even though it is still indicated).

1.8. Low Pressure Failure

The Mira Advance contains a 'LOW PRESSURE' indicator which will operate for three seconds, if the following conditions occur:

1.8.1. Low water pressure (below 0.5 bar maintained).

1.8.2. Blocked or partially blocked spray plate.

1.8.3. Blocked inlet filter.

If any of the above conditions occur, the unit will return to **STOP**.

1.9. The Mira Advance contains a 'SERVICE' indicator which will operate if the following conditions occur:

1.9.1. Abnormal operating conditions (refer to **Maintenance**)

1.9.2. Faulty element or element assembly.

1.9.3. Overheating

Depending on the fault condition the Mira Advance may continue to operate.

1.10. Check the shower temperature before entering the shower. The previous user may have selected a **different** temperature or flow condition.

Temperature Rise Versus Flow for the Mira Advance

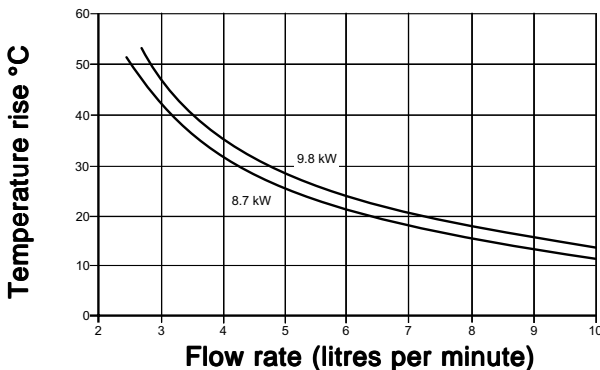

- (i) The curves on the graph are for the specified outputs at 240V from the Mira Advance heater tank outlet.
- (ii) All Mira Advance heating elements have a manufacturing tolerance. Thus flow rates can be above or below those indicated.
- (iii) The left-hand scale is temperature rise. (Temperature rise = Heater tank outlet temperature minus the incoming cold water temperature.)

Note! Because of temperature/flow loss through the shower hose and fittings, the showering flow rate achieved may not accurately match the flow rate given on the graph.

- (iv) At pressures below 1 bar maintained the full flow performance may not be achieved (refer to **1.7. Low Pressure Thermostatic Performance**).

Example: For the Mira Advance 9.8 kW on full power setting with an incoming water supply at 10°C and a heater tank outlet temperature at 42°C, the temperature rise is 32°C. The flow rate is approximately, 4.5 l/min.

2. Mira Advance Operation

THE SPRAY PLATE HOLES MUST BE KEPT CLEAR. The spray plate should be regularly removed and cleaned in descalent. Lack of regular spray plate cleaning will lead to poor performance and cause early failure of the Mira Advance.

- 2.1. **Switch on** the pull-cord or wall mounted switch. The red "**STOP**" indicator on the Mira Advance will provide a visual indication that the power is on.
- 2.2. **Press** one of the three flow buttons, '**HIGH**', '**MEDIUM**' or '**LOW**'. The adjacent green indicator will illuminate and an audible tone will confirm the action.

For the memory control model, press one of the five memory buttons. (The temperature control knob is **inactive** during memory control operation).

- 2.3. **Wait 15 - 20** seconds for warm water to reach the handset. If the '**LOW**' button was pressed then this time may be longer.
- 2.4. If necessary turn the '**TEMPERATURE**' control knob **clockwise** to increase the temperature, or **anticlockwise** to decrease the temperature. **Wait 10–15** seconds for the adjusted temperature to reach the handset. There will be a change in flow rate when the temperature is adjusted. The control knob operates through approximately 3/4 of a turn from cold to hot and features a detent on the final travel to the cold only position.

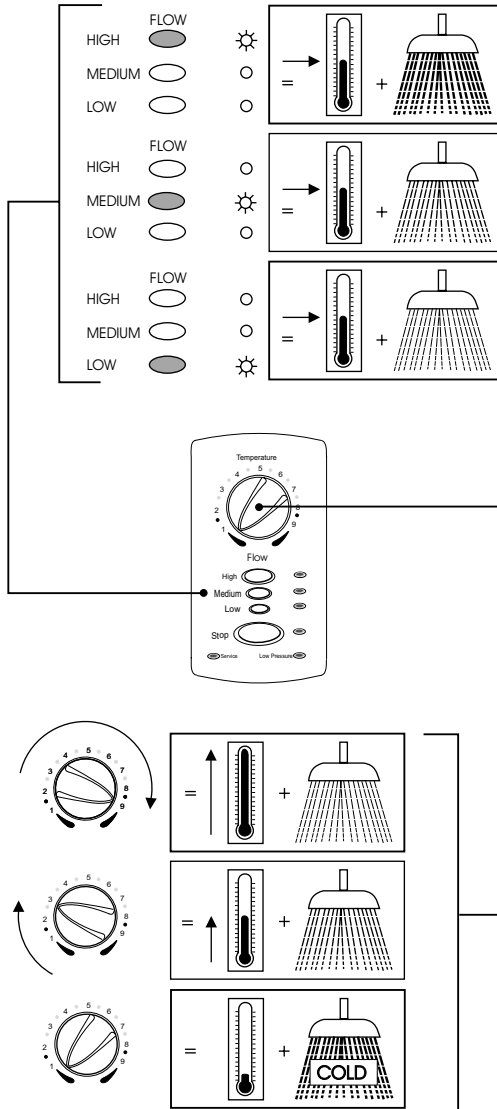

Thermostatic Performance

To maintain thermostatic performance the unit may override the selected flow condition. The selected flow indicated does NOT change.

Low Pressure Thermostatic Performance

The unit maintains thermostatic performance at low pressures, however it may be unable to achieve the desired flow conditions (refer to **1.7. Low Pressure Thermostatic Performance**).

Clockwise → **WARMER** → less flow
Anticlockwise → **COOLER** → more flow

For the memory control model.

To leave memory control mode, and to regain the use of the '**TEMPERATURE**' control knob press one of the following buttons; '**HIGH**', '**MEDIUM**' or '**LOW**'. The shower temperature and flow rate will change from the preset memory button condition to that selected by the chosen flow button and '**TEMPERATURE**' control knob position.

Hint! When returning to standard control, position the '**TEMPERATURE**' control knob at the midpoint i.e. '**TEMPERATURE**' control knob vertical.

- 2.5. IMPORTANT! TO TURN OFF always press the 'STOP' button to allow the Mira Advance to perform its shutdown sequence.** The red indicator will illuminate and an audible tone will confirm the action. The Mira Advance will continue to run for a few seconds before stopping. This phased shutdown is to remove heat from the element assembly and tank body.

- 2.6.** Allow a few moments before turning off the pull-cord switch.

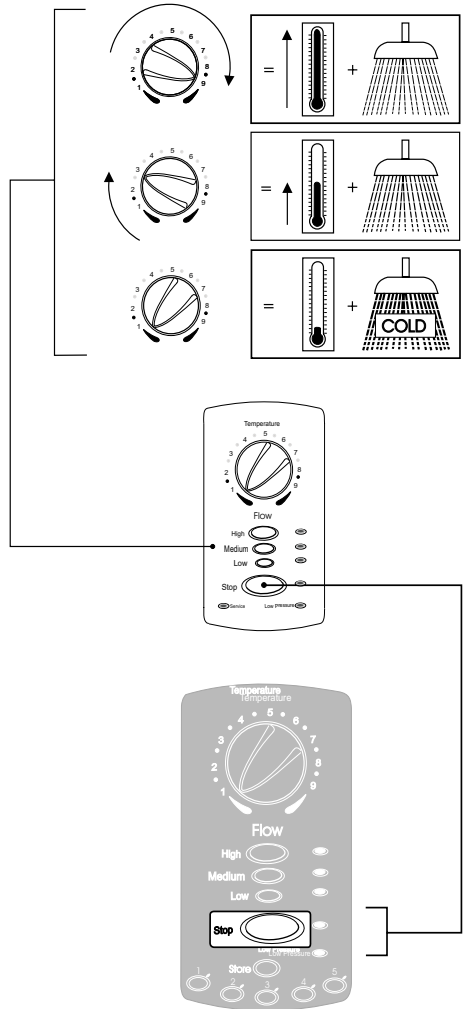

3. Storing the Memory Presets (Memory control model only)

Should you wish to change the five factory presets, proceed as follows:

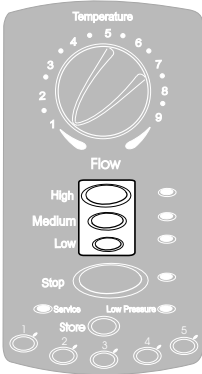

Step 1

Select your personal flow setting.

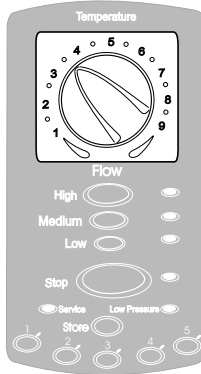

Step 2

Select your personal temperature setting.

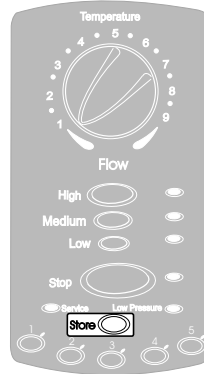

Step 3

Press 'STORE'

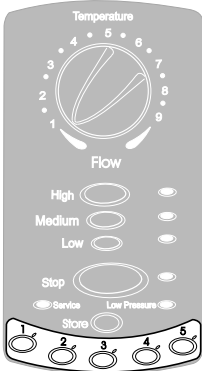

Step 4

Press one of the numbered preset buttons

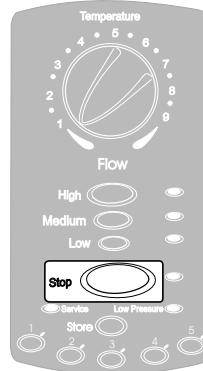

Step 5

Press 'STOP' before turning off the Mira Advance

Note! If the electrical supply is isolated without operating the stop button the memory setting will be lost. The 'Storing Memory' preset procedure will need to be repeated.

1. Operators Troubleshooting Guide

Read the section **"Important Safety Information"** first.

The Mira Advance electric shower is fully performance tested after assembly. In the unlikely event that you experience problems with the Mira Advance, then the following procedures will enable you to undertake basic troubleshooting before contacting the person responsible for installing your shower.

WARNING! There are no user serviceable components beneath the cover of the Mira Advance. Only a competent tradesperson should remove the cover.

Key

A = "STOP" indicator – ✓ = light illuminated (right-hand side of button)

B = "LOW PRESSURE" indicator – ✓ = light illuminated (right-hand side for 3 seconds only, then returns to STOP)

C = "SERVICE" indicator – ✓ = light illuminated (left-hand side)

D = "FLOW INDICATION"

Malfunction	A	B	C	D	Cause	Remedy
No water or very low flow rate and then the unit switches off.	✓	✓			Spray plate blocked.	Remove and clean. Refer to fittings guide.
	✓	✓			Supply stop valve turned down.	Turn on.
No visible flow change on flow selection change. Low flow rate.				✓	Low pressure thermostatic performance.	This is normal during low pressure thermostatic performance. Improve supply pressure.
	✓	✓			Insufficient water supply pressure.	Contact a competent tradesperson.
Sudden rapid increase in flow for a short period, eventually returning to expected flow and temperature. This may occur after a period of non-use.				✓	A section of supply pipe allows pre-heating of water supply to the shower ie. running through a warm loft or next to hot pipes.	Allow shower to run for a couple of minutes before entering shower to allow warmer water to clear the system.

Malfunction	A	B	C	D	Cause	Remedy
Mira Advance fails to operate in any button position.			✓		Double-pole switch isolated. Supply fuse failed, MCB or RCD tripped.	Switch on. Contact a competent tradesperson.
	✓				Incoming water supply below 1°C. Temporary interruption of supply voltage.	No remedy. Press one of the flow buttons or memory preset buttons.
Service light flashes and the flow will not stop after STOP button is pressed.			✓		Over temperature. or Abnormal site conditions.	Turn off the electrical supply by operating pull-cord switch, wait for a few moments (approx. 10 secs) for Mira Advance to reset , turn on pull-cord switch and operate Mira Advance. If problem still persists then contact Caradon Plumbing Solutions for advice.
Any other fault condition.			✓			
Visible flow change (not pulsating) without user selection. User selection lights remain unchanged.				✓	Thermostatic operation.	This is normal to maintain thermostatic performance
No visible flow change on flow selection change.				✓	Thermostatic performance.	This is normal to maintain thermostatic performance under some conditions.

2. Installer Fault Diagnosis

Read the section "**Important Safety Information**" first.

WARNING! Isolate the electrical and water supply before removing the cover.

WARNING! Mains connections are exposed when the cover is removed.

WARNING! Refer to wiring diagram before making any electrical connections.

WARNING! Ensure all electrical connections are tight to prevent overheating.

WARNING! Ensure all plumbing connections are watertight.

Providing the Mira Advance has been correctly installed and is operated in accordance with the instructions contained in this guide, difficulties should not arise. If any maintenance is required then it must be carried out by a competent tradesperson for whom the fault diagnosis chart, wiring diagram and maintenance instructions are provided. Before replacing any parts ensure that the underlying cause of the malfunction has been resolved.

When following these instructions, it is sometimes necessary to examine the Mira Advance with the electrical supply turned on, as well as the water supply. It is therefore essential that the appropriate safe working practices are followed in accordance with the current Health And Safety Legislation.

Using a device for measuring continuity (DVM, AVO Voltmeter), follow through the following tests.

Key

A = "FLOW" or "STOP" indicator – ✓ = light illuminated (right-hand side of button)

B = "LOW PRESSURE" indicator – ✓ = light illuminated (right-hand side) for 3 seconds

C = "SERVICE" indicator – ✓ = light illuminated (left-hand side)

Note! Where more than one tick is indicated, any or all of the lights can be illuminated.

Malfunction	A	B	C	Cause	Remedy
Mira Advance appears dead.				Supply fuse failed, MCB or RCD tripped. Poor internal wire connections.	Rectify fault and replace fuse or reset. Check integrity of internal wiring. Check multi connector plug (wire 78) is pushed fully home.

Malfunction	A	B	C	Cause	Remedy
				Faulty transformer. Faulty relay board assembly. Faulty control PCB.	Renew transformer. Renew relay board assembly. Renew control PCB.
No water or very low flow rate. Service light not on.	✓	✓		Inlet strainer blocked.	Remove and clean. When refitted ensure filter is screwed fully home.
		✓	✓	Faulty flow valve.	Renew flow valve.
		✓		Faulty relay board assembly.	Renew relay board assembly.
		✓		Faulty element assembly.	Renew element assembly.
		✓	✓	Insufficient water supply pressure.	Check water supply isolation.
		✓		Low pressure thermostatic performance.	See Operation
				Faulty or incorrectly connected wire 78 multi-connector.	Renew or reconnect wire 78 multi-connector. Ensure that the connector is fully pushed home.
Mira Advance continues to drip after being turned off, or will not shut off.	✓			Faulty flow valve.	Renew flow valve.
		✓		Shower head will continue to drip for a period of time once the shower is turned off.	Change angle of shower head to speed up the discharge of retained water.

Malfunction	A	B	C	Cause	Remedy
Mira Advance leaks from bottom of case.				Faulty flow valve. Faulty tank seal. Faulty tank body/sensor assembly.	Renew flow valve. Renew tank seal. Renew tank body/sensor assembly. Dry thoroughly before retrying unit.
Control panel malfunction. e.g. No audible tone, continuous tone, indicators do not correspond with button depression or indicators do not illuminate.				Faulty control PCB. Faulty wire 78 multi-connector.	Renew control PCB. Renew wire 78 multi-connector.
Shower heats water but does not get hot enough.				43°C link wire on control PCB cut. Faulty outlet sensor.	Re-solder link or renew control PCB. Renew outlet sensor.
Shower flow rate pulsates.				Air trapped in flow valve. Faulty inlet sensor. Debris in flow valve turbine. Pressure above 10 bar maximum.	With electrical supply off, press air bleed button several times. Note! Water at full mains supply pressure will flow from the handset and a small amount of water will be discharged from under the air bleed button. Renew flow valve. Clean turbine. Fit pressure reducing valve.

Malfunction	A	B	C	Cause	Remedy
Rapid continuous cycling of relays.				Faulty inlet sensor. Debris in flow valve turbine.	Renew flow valve. Clean turbine.
When unit switched on service light flashes and the flow will not stop after STOP button is pressed.			✓	Wet electronics or faulty relay board.	Dry out relay board, control board and wire 78. Renew relay board.
Intermittent Service light illumination during operation. or Any other fault condition.			✓ ✓	Abnormal site conditions.	Turn off the electrical supply by operating pull-cord switch, wait for a few moments (approximately 10 seconds) for Mira Advance to reset , turn on pull-cord switch and operate Mira Advance. If problem still persists then contact Caradon Mira for advice
Service light on when flow selected. Service light remains on - no flow			✓ ✓	Faulty inlet sensor. Faulty outlet sensor.	Renew inlet sensor. Renew tank assembly.
High flow rate - low pressure light comes on, unit then goes to stop.	✓	✓		Faulty inlet sensor. Debris in flow valve turbine. Poor wire 78 (multi-connector) connection.	Renew inlet sensor. Clean turbine. Check filter is screwed fully home. Check integrity of wire 78 connection. Ensure that the connector is fully pushed home.

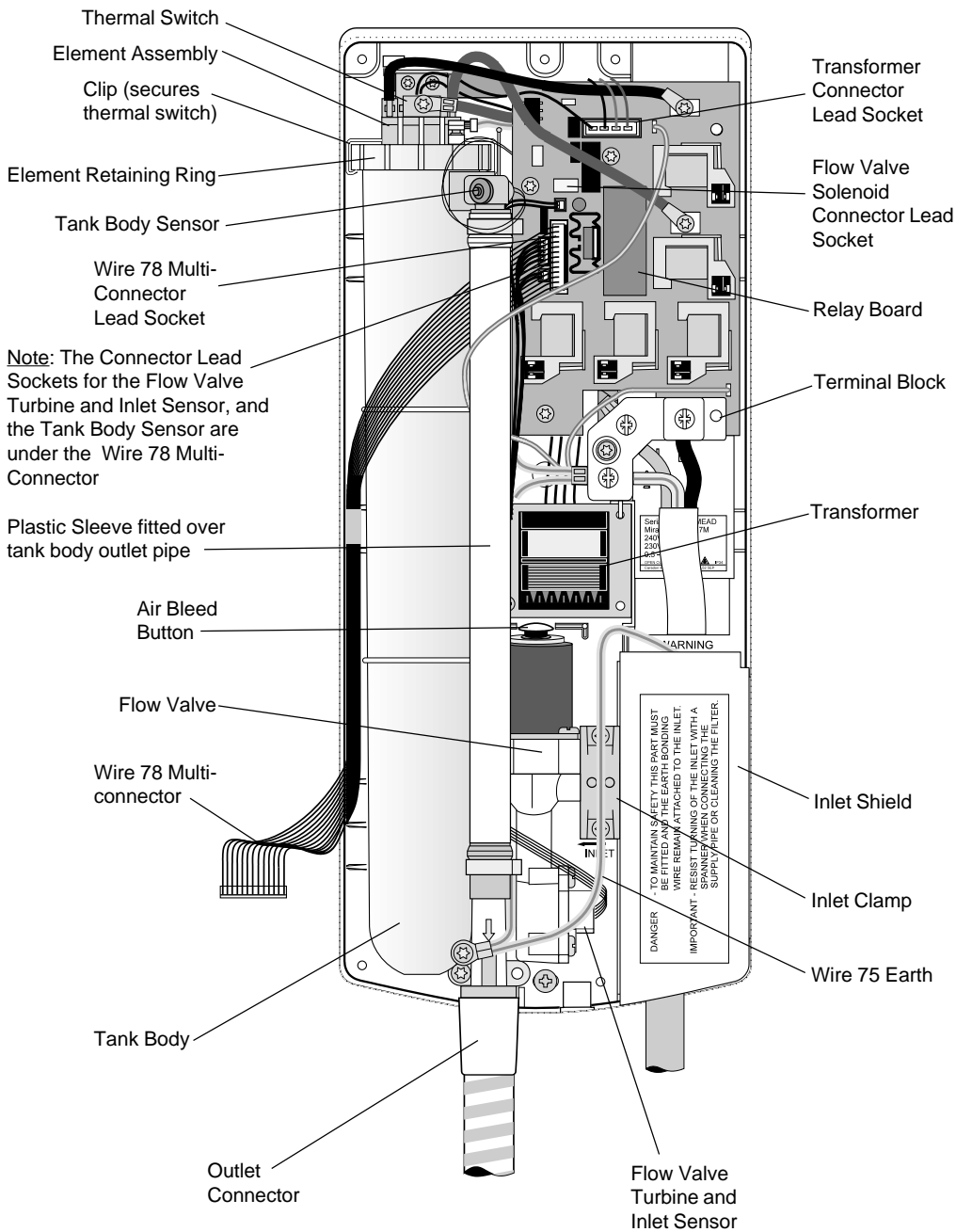

1. Cleaning

Read the section “**Important Safety Information**” first.

- 1.1. Many household cleaners contain abrasives and chemical substances, and should not be used for cleaning plated or plastic fittings. These finishes should be cleaned with a mild washing up detergent or soap solution, and then wiped dry using a soft cloth.
- 1.2. Spray pattern deterioration can be caused by either, debris trapped in the spray head, or a limescale buildup in the spray holes. The spray head can be removed and cleaned in a proprietary plastic kettle descaler, following the manufacturer’s instructions.
- 1.3. To clean the head or spray plate, please refer to the appropriate section in the Installation, Operation and Maintenance Guide which accompanies the shower fittings.

2. Mira Advance Cover – Removal and Refitting

- 2.1. To remove the cover:
 - 2.1.1. Remove the screw located at the bottom of Mira Advance case.
 - 2.1.2. **Caution!** The cover is connected to the case by wire 78 Multi-connector, which should not be strained when carrying out the next instruction (Refer to Figure 4).
 - 2.1.3. Carefully pull the bottom of cover outwards and upwards off case.
 - 2.1.4. Carefully remove the wire 78 multi-connector from the socket on the control PCB, in the cover if the maintenance procedure requires.

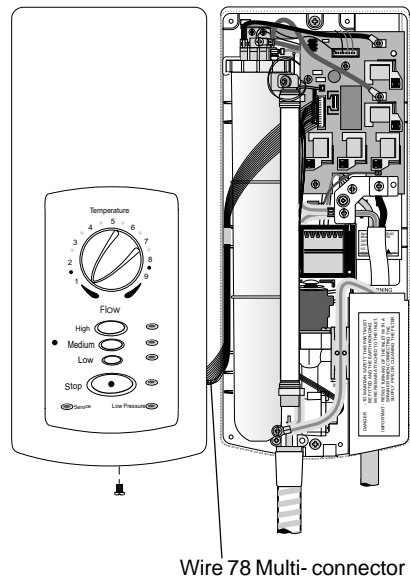

Figure 4

2.2. To refit the cover:

2.2.1. Connect the wire 78 multi-connector to the socket on the control PCB. The wire 78 multi-connector lead plug is a one way fit into the socket and must be pushed fully home (Refer to Figure 5).

2.2.2. Refit the cover by locating the top of the cover onto the location strip on top of the case. Ensure that the wire 78 multi-connector lead is seated between the tank body and the left-hand side of the case.

2.2.3. Push the bottom of the cover against the case until it locates correctly. Install the screw and tighten.

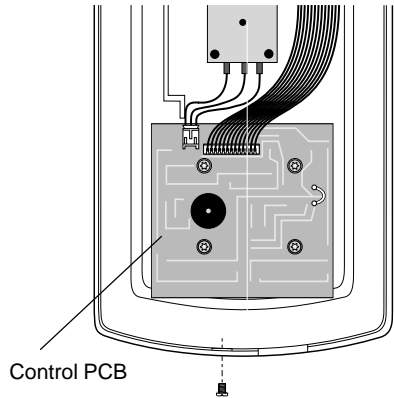

Figure 5

3. Relay Board – Renewal

3.1. To renew the relay board assembly:

- 3.1.1. Remove all the plug-in multi connectors.
- 3.1.2. Remove the terminal block cover retaining screws and the cover.
- 3.1.3. Remove the wires to the element assembly.
- 3.1.4. Remove the two earth fly leads.
- 3.1.5. Remove the relay board retaining screws.
- 3.1.6. Renew the relay board.
- 3.1.7. Refit in reverse order.

4. Transformer – Renewal

4.1. To renew the transformer:

- 4.1.1. Isolate the electrical power.
- 4.1.2. Remove the terminal block cover.
- 4.1.3. Remove the two upper relay board retaining screws.
- 4.1.4. Unplug the transformer connector lead.
- 4.1.5. Remove the transformer retaining screw.
- 4.1.6. Unplug the following:
 - Solenoid plug PL8
 - Flow sensor plug PL4
 - Outlet sensor plug PL3.

- 4.1.7. Remove the two earth fly leads device leads fitted to the relay board.
- 4.1.8. Remove the element connections and remove the relay board.
- 4.1.9. Remove the transformer and unclip the thermal switch on top of the heater element. Remove the thermal switch.
- 4.1.10. Refit in reverse order. Make sure that:
 - the transformer wires do not become trapped underneath the transformer or busbar when refitting.
 - the thermal switch makes good contact with the tank top.

5. Temperature Potentiometer – Renewal

5.1. To renew the temperature potentiometer:

- 5.1.1. Disconnect the three-pin connector lead from the control PCB, located inside the Mira Advance cover.
- 5.1.2. Remove 'TEMPERATURE' control knob.
- 5.1.3. Undo the temperature potentiometer retaining nut and remove the washer.
- 5.1.4. Renew the temperature potentiometer, locate into recess.
- 5.1.5. Refit in reverse order.

6. Inlet Filter – Cleaning

6.1. To clean the inlet filter:

- 6.1.1. Remove the inlet shield.
- 6.1.2. Hold a wrench across the flats of the inlet connector assembly to prevent damage to the connector, and unscrew the inlet filter (Refer to Figure 6).
- 6.1.3. Withdraw the inlet filter. Clean or renew as necessary.
- 6.1.4. Refit in reverse order. **Ensure that the filter is screwed fully home.**

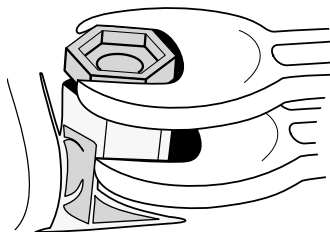

Figure 6

7. Inlet Connector Assembly – Renewal

- 7.1. To renew the inlet connector assembly:
 - 7.1.1. Remove the inlet shield.
 - 7.1.2. Remove the inlet clamp retaining screws.
 - 7.1.3. Remove the inlet clamp.
 - 7.1.4. Remove the earth bonding screw and cable.
 - 7.1.5. Undo the compression nut and slide clear.
 - 7.1.6. Renew the inlet connector assembly.
 - 7.1.7. Refit in reverse order. Ensure the earth bonding wire is securely refitted.

8. Draining the Mira Advance

All the remaining maintenance procedures **require** that the Mira Advance is drained.

- 8.1. To drain the Mira Advance:
 - 8.1.1. Remove the shower hose.
 - 8.1.2. Remove the inlet shield.
 - 8.1.3. Remove the hose outlet connector retaining screws.
 - 8.1.4. Locate release tab of hose outlet connector, underneath the flexible outlet pipe.
 - 8.1.5. Rest a screwdriver on the interconnecting pipe to flow valve. Gently lever the tab upwards.

Caution! Do not try and force the outlet connector off by hand.
 - 8.1.6. Move the flexible outlet pipe away to the right of flow valve.
 - 8.1.7. Lift and partially separate the flow valve from the outlet of heater tank. Allow the water to drain out of the bottom of Mira Advance.
 - 8.1.8. When relevant maintenance procedure has been completed, refit in reverse order.
- 8.2. To renew the flow valve:
 - 8.2.1. Refer to **Section 8, Maintenance: "8.1. To drain the Mira Advance"** and follow instructions **8.1.1.** to **8.1.7.** inclusive.
 - 8.2.2. Remove the flow valve turbine and inlet sensor connector lead (5 wires) from the relay board.
 - 8.2.3. Remove the flow valve solenoid connector lead (2 wires) from the relay board.
 - 8.2.4. Remove the inlet clamp retaining screws and clamp.
 - 8.2.5. Separate the flow valve from the tank body and the inlet connector.
 - 8.2.6. Renew the flow valve.

- 8.2.7.** Refit the remaining components in reverse order. Make sure that the wiring is correctly routed and clears the flow valve air bleed button, and that all the screws are tight.
- 8.3.** To clean the flow valve turbine:
- 8.3.1.** Refer to **Section 8, Maintenance: "8.2. To renew the flow valve"** and follow instructions **8.2.1.** to **8.2.5.** inclusive.
- 8.3.2.** Remove the three flow valve turbine and inlet sensor retaining screws.
- 8.3.3.** Separate the turbine from the housing.
- 8.3.4.** Clean turbine and the annular groove in the housing in which the turbine rotates.
- 8.3.5.** Refit in reverse order. The turbine is a one-way fit into the housing and the retaining screws for the housing must be tightened evenly to prevent damage.
- 8.4.** To renew the tank body/sensor assembly:
- 8.4.1.** Refer to **Section 8, Maintenance: "8.1. To drain the Mira Advance"** and follow instructions **8.1.1.** to **8.1.7.** inclusive.
- 8.4.2.** Remove the wire 75 earth from the outlet connector.
- 8.4.3.** Remove the tank body/sensor connector lead (2 wires) from the relay board and unclip the thermal switch clip.
- 8.4.4.** Unscrew the element retaining ring.
- 8.4.5.** Loosen the inlet clamp retaining screws.
- 8.4.6.** Separate the tank body/sensor assembly from the flow valve and slide it off the element assembly.
- 8.4.7.** Renew the tank body/sensor assembly. Make sure that the location spigot on the tank body/sensor assembly engages in the cutout in the element assembly.
- 8.4.8.** Refit the remaining components in reverse order. Make sure that the wiring is correctly routed, and that all the screws are tight. Make sure that the thermal switch clip is fitted correctly.
- 8.4.9.** When fitting the wire 75 earth to the outlet connector, fully tighten shower hose first to ensure the seal inside the outlet connector is compressed.
- 8.5.** To renew the element assembly:
- 8.5.1.** Refer to **Section 8, Maintenance: "8.1. To drain the Mira Advance"** and follow instructions **8.1.1.** to **8.1.7.** inclusive.
- 8.5.2.** Remove the wires and screws that connect the element assembly.
- 8.5.3.** Swivel the top of the tank body/sensor assembly forward and unclip the thermal switch clip and unscrew the element retaining ring.

- 8.5.4. Withdraw the element assembly from tank body/sensor assembly.
- 8.5.5. Renew element assembly. Make sure that the location spigot on the tank body/sensor assembly engages in the cutout in the element assembly.
- 8.5.6. Refit in reverse order. To prevent overheating, make sure that the wiring is correctly routed, and that all the screws are tight and are not cross-threaded. Make sure that the thermal switch clip is fitted correctly.
- 8.6. To clean the element assembly:
 - 8.6.1. Refer to **Section 8, Maintenance: "8.5. To renew the element assembly"** and remove the element assembly.
 - 8.6.2. Unclip the thermal switch clip and remove the element retaining ring and the seal.
 - 8.6.3. Immerse the element assembly up to the flange in a proprietary plastic kettle descalent. Follow the descalent manufacturer's instructions. **DO NOT allow the solution to come into contact with the element assembly terminals or the plastic components.**

Note! Heater elements may be damaged by excessive use of descalent solution.
 - 8.6.4. Refer to **Section 8, Maintenance: "8.4. To renew the tank body/sensor assembly"** and remove the tank body/sensor assembly.
 - 8.6.5. Rinse out the tank body/sensor assembly in cold water to remove any limescale.

DO NOT immerse tank body/sensor assembly in descalent.
 - 8.6.6. Refit in reverse order. Make sure that the thermal switch clip is fitted correctly.

For healthcare or special need requirements, Mira recommend that you carry out the procedure detailed below.

The Mira Advance has the facility to limit the maximum temperature to a special low value of 43°C if required.

The Mira Advance is fitted with a removable link wire, which can be cut to reset the normal operating limit of 48°C to the lower value of 43°C.

This procedure is not easily reversible, careful consideration should be given before proceeding.

WARNING! Isolate the electrical and water supply before removing the cover.

WARNING! Refer to wiring diagram before making any electrical connections.

- 1.1. Use a screwdriver to remove the screw from the bottom of the case.

Caution! The cover is connected to the case by the wire 78 multi-connector, which should not be strained when carrying out the next instruction.

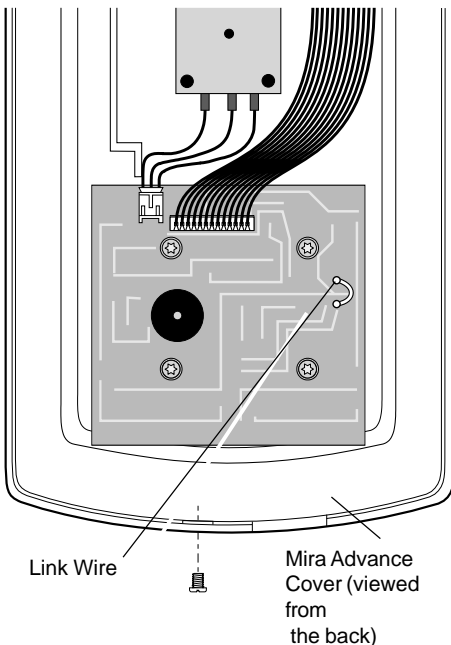

- 1.2. Pull the bottom of the cover outwards and upwards off the case.
- 1.3. The link wire is located on the control PCB, inside the Mira Advance cover assembly (Refer to Figure 8).
- 1.4. Remove the link wire cleanly, using small gauge wire cutters.
- 1.5. Refit the cover by locating the top of the cover onto the location strip on the top of the case. Make sure that the wire 78 multi-connector lead is seated between the tank body and the left-hand side of the case and is pushed fully home.
- 1.6. Push the bottom of the cover against the case. Fit the screw and tighten.

Figure 8

Spare Parts

1. Spare Parts List (memory model)

405 05	Element Retaining Ring
405 32	Tank Body/Sensor Assembly
405 36	Inlet Shield
405 50	Inlet Sensor
405 56	Wire 78 Multi-connector
405 58	Inlet Connector Assembly
405 73	Memory Control PCB
406 19	Element 9kW/230V 9.8kW/240V
406 20	Element 8kW/230V 8.7kW/240V
406 21	Flow Valve
406 22	Transformer - components identified 'D'
406 25	Seals Pack - components identified 'A'
406 26	Screw Pack - components identified 'B'
406 27	Inlet Filter
406 28	Component Pack - components identified 'C'
406 38	Top Case Insert
406 46	Terminal Block
406 88	Relay Board + Wire 75
430 27	Cover Assembly Memory (with Temperature Potentiometer)

Accessories

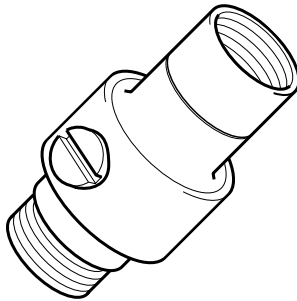

DCV-H: An outlet double check valve, designed to prevent the backflow or backsiphonage of potentially contaminated water, through shower controls which are fitted with a flexible hose as part of the outlet shower fitting. Available as an optional accessory from your Caradon Plumbing Solutions stockists.

2. Spare Parts Diagram (memory model)

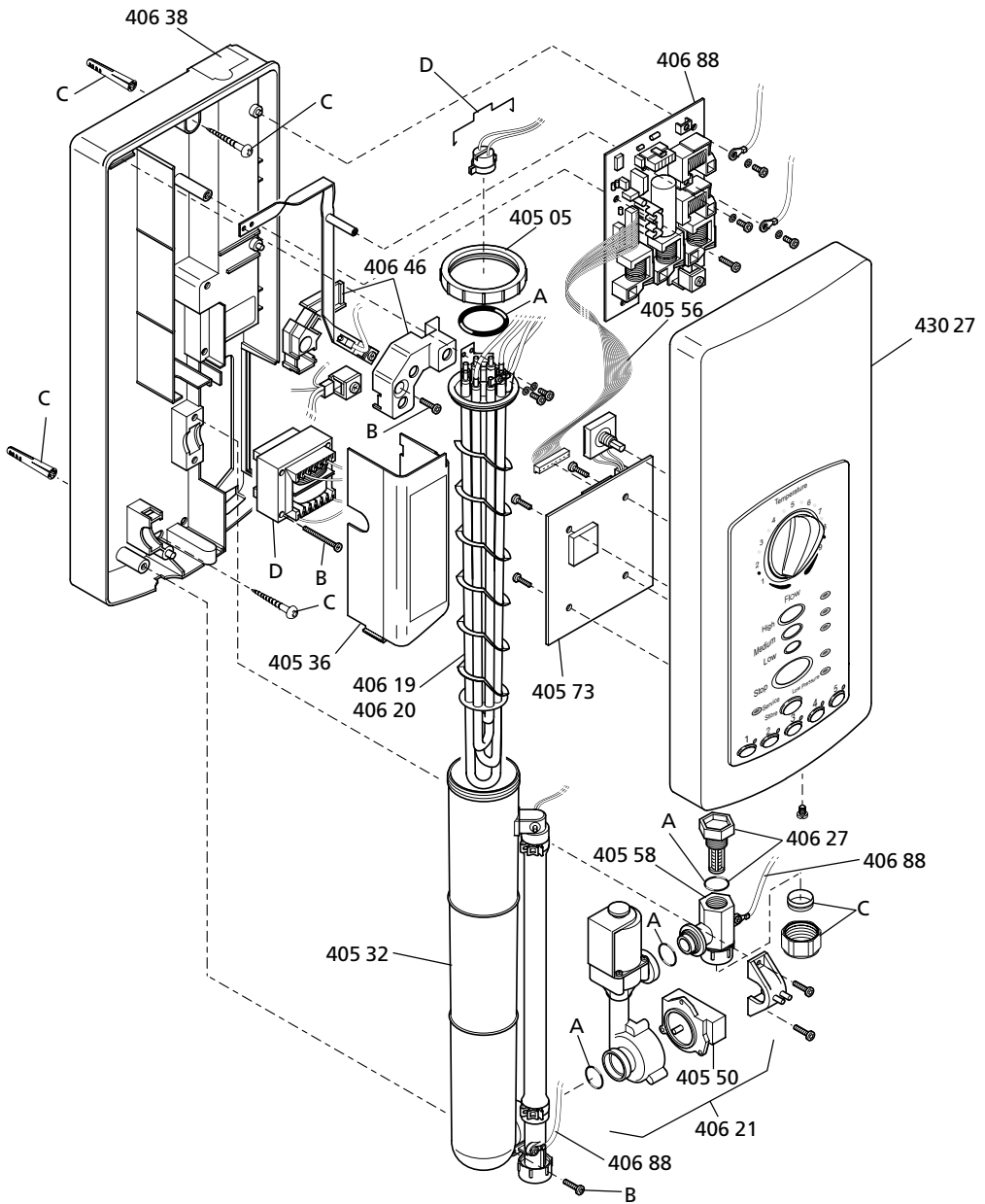

3. Spare Parts List (standard model)

405 05	Element Retaining Ring
405 32	Tank Body/Sensor Assembly
405 36	Inlet Shield
405 50	Inlet Sensor
405 56	Wire 78 Multi-connector
405 58	Inlet Connector Assembly
405 72	Control PCB
406 19	Element 9kW/230V 9.8kW/240V
406 20	Element 8kW/230V 8.7kW/240V
406 21	Flow Valve
406 22	Transformer - components identified 'D'
406 25	Seals Pack - components identified 'A'
406 26	Screw Pack - components identified 'B'
406 27	Inlet Filter
406 28	Component Pack - components identified 'C'
406 38	Top Case Insert
406 46	Terminal Block
406 88	Relay Board + Wire 75
430 26	Cover Assembly (with Temperature Potentiometer)

Accessories

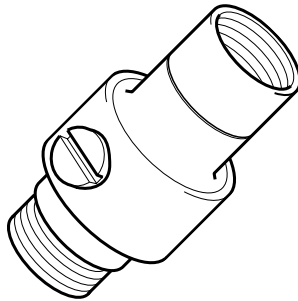

DCV-H: An outlet double check valve, designed to prevent the backflow or backsiphonage of potentially contaminated water, through shower controls which are fitted with a flexible hose as part of the outlet shower fitting. Available as an optional accessory from your Caradon Plumbing Solutions stockists.

4. Spare Parts Diagram (standard model)

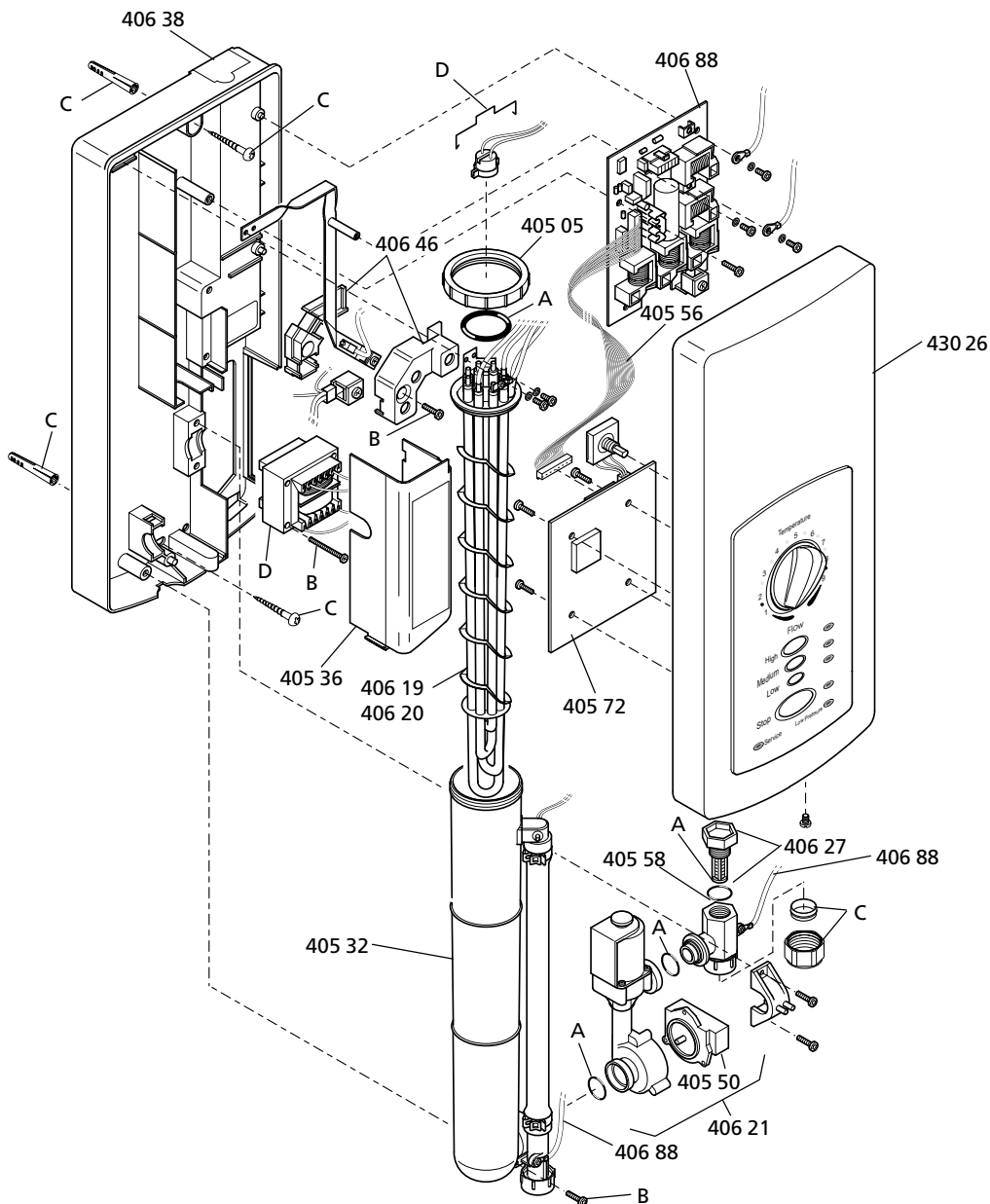

Customer Service

Guarantee

Caradon Plumbing Solutions guarantee this product against any defect of materials or workmanship for one year (three years for the Mira Excel thermostatic range) from the date of purchase, provided that the product has been installed correctly and used and maintained in accordance with the instructions supplied.

Any part found to be defective during the guarantee period will be replaced or repaired – at our option – without charge, provided that the product has been properly used and maintained.

The product should not be taken apart, modified or repaired except by a person authorised by Caradon Plumbing Solutions.

Your statutory rights are in no way affected by this guarantee.

After Sales Service – how we can help you

Caradon Plumbing Solutions have a team of expert staff ready to provide assistance, should you experience any difficulty with your Mira shower.

The Caradon Plumbing Solutions Customer Services is available to give you advice on any problem encountered. Should the problem be unable to be resolved by advice, we will offer either a replacement part to be sent to you, or for one of our Service Engineers or Agents to call.

Spare Parts

At Caradon Plumbing Solutions we keep a stock of all functional parts of our products for up to ten years from the date of final manufacture of the product.

If during that period, our stock of a particular part is exhausted we will, as an alternative, provide an equivalent new product or part at a price equating to the cost of repair to the old, bearing in mind the age of the product.

Caradon Plumbing Solutions will normally despatch spare parts within two working days and by 1st class post. In the interests of customer safety, spares that require exposure to areas of mains voltage can only be sent to a competent person.

Payment for such parts – if applicable – can be made by Visa or Access over the phone at the time of ordering. Should payment by cheque be preferred a pro forma invoice will be sent.

Customer Care Policy

If within a short time of installation the product does not function correctly, first check with the Installation, Operation and Maintenance Guide to see if the difficulty can be overcome by simple home maintenance.

Failing this, contact your installer to ensure that the product has been installed and commissioned in full accord with our detailed installation instructions. Our Customer Services is available, on the number shown below, to advise you or your installer.

If this does not resolve the difficulty, contact our Customer Services who will give every assistance and, if appropriate, arrange for our local Service Engineer or Agent to call on a mutually agreeable date.

If, through circumstances beyond our control, we are unable to provide this cover we will, with prior agreement, authorise a competent local installer to attend.

Within the Guarantee period there will be no charge for the parts or labour insofar as a fault with our product is concerned. However, it is important to appreciate that our Guarantee extends to our product only and that it does not cover difficulties arising from incorrect installation or misuse.

During a Service visit a responsible person – familiar with the purpose of the visit – should be present. Should our Service Engineer or Agent be unable to gain access at the prearranged time a callout charge may be made.

Payment for Service visits, if applicable, should be made directly to the Service Engineer or Agent, using either Visa, Access or a cheque supported by a banker's card.

To contact us:- For England, Wales and Scotland

Telephone 01242 262888
and ask for **Caradon Plumbing Solutions Customer Services**

- For advice on product maintenance
- To order spare parts
- To arrange a service visit
- For product advice and problem solving
- To order Installation, Operation and Maintenance Guides
- For your feedback on our products or services

By Fax: (01242) 282595

By Post: Caradon Plumbing Solutions, Cromwell Road
Cheltenham, Gloucestershire, GL52 5EP.

For Northern Ireland

By Phone: 01232 401909 – Monday to Friday 9am–5pm

By Fax: 01232 401235 – 24 Hours

By Post: Wm. H. Leech & Son Ltd, Unit 3,
34, Montgomery Road, Belfast, BT6 9HL.

For Eire

By Phone: Dublin 01 4591344 – Monday to Friday 9am–5pm

By Fax: Dublin 01 4592329 – 24 Hours

By Post: Modern Plant Ltd, Otter House, Naas Road,
Clondalkin, Dublin 22, Eire.

Mira Showers

Caradon Plumbing Ltd
Cromwell Road,
Cheltenham GL52 5EP.

Mira is a registered trade mark of subsidiaries of Caradon plc.
The company reserves the right to alter product specifications without notice.

www.mira-showers.com
mira_technical@caradon.com



BS EN ISO 9001:1994
Reg. No. FM 14648

Caradon 
Plumbing Solutions