



Record your model number:

记录您的型号:

บันทึกหมายเลขรุ่นของคุณ: \_\_\_\_\_

**⚠ WARNING: Risk of scalding.** High water temperature can cause severe burns. Set the valve water temperature at or below 120°F (49°C). Refer to the temperature adjustment instructions for the valve.

Follow all local plumbing and building codes.

1A. Sealant Tape

1B. G1/2 Supply Elbows

2A. Install two supply elbows 5-7/8" (150 mm) apart.

3A. Cap one of the ports on the back of the bracket.

6A. Install the finished wall.

6B. Trim the plastic guards so that they are flush with the finished wall.

8A. Turn ON the water supplies to flush debris.

10A. Verify that the offset connectors protrude 1-5/16" (33 mm) - 1-3/4" (44 mm) from the finished wall. Change or adjust the z-connectors if necessary.

10B. Verify that the offset connectors are 5-7/8" (149 mm) - 5-15/16" (151 mm) from center to center and level. Adjust if necessary.

13A. Install the handshower and showerhead according to the manufacturers instructions.

**Need help?** Contact our Customer Care Center.

• Thailand: [callcenterthailand@kohler.com](mailto:callcenterthailand@kohler.com), +(66) 2700-9299

• Australia: 1800 KOHLER (1800-564-537)

• New Zealand: 0800-564-537

• Mainland China: +(86) 800-820-2628, +(86) 400-820-2628

• Hong Kong (China), Macau (China), Taiwan (China): +(852) 3125-7728

• Brunei, Guam, Indonesia, Japan, Malaysia, Mongolia, Philippines, Singapore, South Korea, Vietnam: +(86) 21-2606-2572

This product is covered under the **Five-Year Limited Warranty for KOHLER® Faucets**, found in the packed Compliance Certification.

**⚠ 警告：提防烫伤风险。**水温过高会导致严重灼伤。应将阀芯水温设置为等于或低于 120°F (49°C)。请参考阀芯的温度调节说明。

遵守所有当地给排水及建筑规定。

1A. 密封胶带

1B. G1/2 供水弯头

2A. 安装两个相距 5-7/8 英寸 (150 毫米) 的供水弯头。

3A. 盖上支架背面的一个端口。

6A. 完成墙面的最后安装。

6B. 修剪塑料护罩，使其与成品墙齐平。

8A. 打开供水系统以冲洗杂质。

10A. 确认偏置接头是否从成品墙伸出 1-5/16 英寸 (33 毫米) - 1-3/4 英寸 (44 毫米)。如有必要，请更换或调整 z 连接器。

10B. 确认偏置接头从中心到中心和水平的距离为 5-7/8 英寸 (149 毫米) - 5-15/16 英寸 (151 毫米)。必要时进行调整。

13A. 按照制造商的说明安装手握式花洒和莲蓬头。

**如需帮助，** 请联系我们的客户服务中心。

• 泰国: [callcenterthailand@kohler.com](mailto:callcenterthailand@kohler.com), +(66) 2700-9299

• 澳大利亚: 1800 KOHLER (1800-564-537)

• 新西兰: 0800-564-537

• 中国大陆: +(86) 800-820-2628, +(86) 400-820-2628

• 中国香港、中国澳门、中国台湾: +(852) 3125-7728

• 文莱、关岛、印度尼西亚、日本、马来西亚、蒙古、菲律宾、新加坡、韩国、越南: +(86) 21-2606-2572

本产品支持科勒®水龙头五年有限担保，详见包装所附的《合格证》。

**⚠ คำเตือน: ความเสี่ยงต่อการถูกน้ำร้อนลวก อุณหภูมิที่สูงของน้ำอาจทำให้เกิดแผลพุพองอย่างรุนแรง ตั้งอุณหภูมิที่ต่ำสุดไม่เกิน 120°F (49°C) โปรดดูคำแนะนำเกี่ยวกับการปรับอุณหภูมิของวาล์ว**

ปฏิบัติตามระเบียบปฏิบัติเกี่ยวกับระบบประปาและอาคารในท้องถิ่นทั้งหมด

1A. เทปกันน้ำซึม

1B. ข้อต่อจ่ายน้ำ G1/2

2A. ติดตั้งข้อต่อสำหรับการจ่ายสองข้อห่างกัน 5-7 / 8 นิ้ว (150 มม.)

3A. ปิดหนึ่งช่องที่ด้านหลังของโครงยึด

6A. ติดตั้งผนังสำเร็จรูป

6B. ตัดแต่งการ์ดพลาสติกเพื่อให้ชิดกับผนัง

8A. เปิดน้ำจากการประปาเพื่อล้างเศษขยะ

10A. ตรวจสอบว่าข้อต่อออกฟิเซดยื่นออกมา 1-5/16 นิ้ว (33 มม.) - 1-3/4 นิ้ว (44 มม.) จากผนัง เปลี่ยนหรือปรับข้อต่อ Z หากจำเป็น

10B. ตรวจสอบว่าข้อต่อออกฟิเซดมีขนาด 5-7/8 นิ้ว (149 มม.) - 5-15/16 นิ้ว (151 มม.) จากจุดศูนย์กลางถึงจุดศูนย์กลางและระดับ ปรับถ้าจำเป็น

13A. ติดตั้งสายฝักบัวและหัวฝักบัวตามคำแนะนำของผู้ผลิต

ต้องการความช่วยเหลือหรือไม่ โปรดติดต่อศูนย์บริการลูกค้าของเรา

• ประเทศไทย: [callcenterthailand@kohler.com](mailto:callcenterthailand@kohler.com), + (66) 2700-9299

• ออสเตรเลีย: 1800 KOHLER (1800-564-537)

• นิวซีแลนด์: 0800-564-537

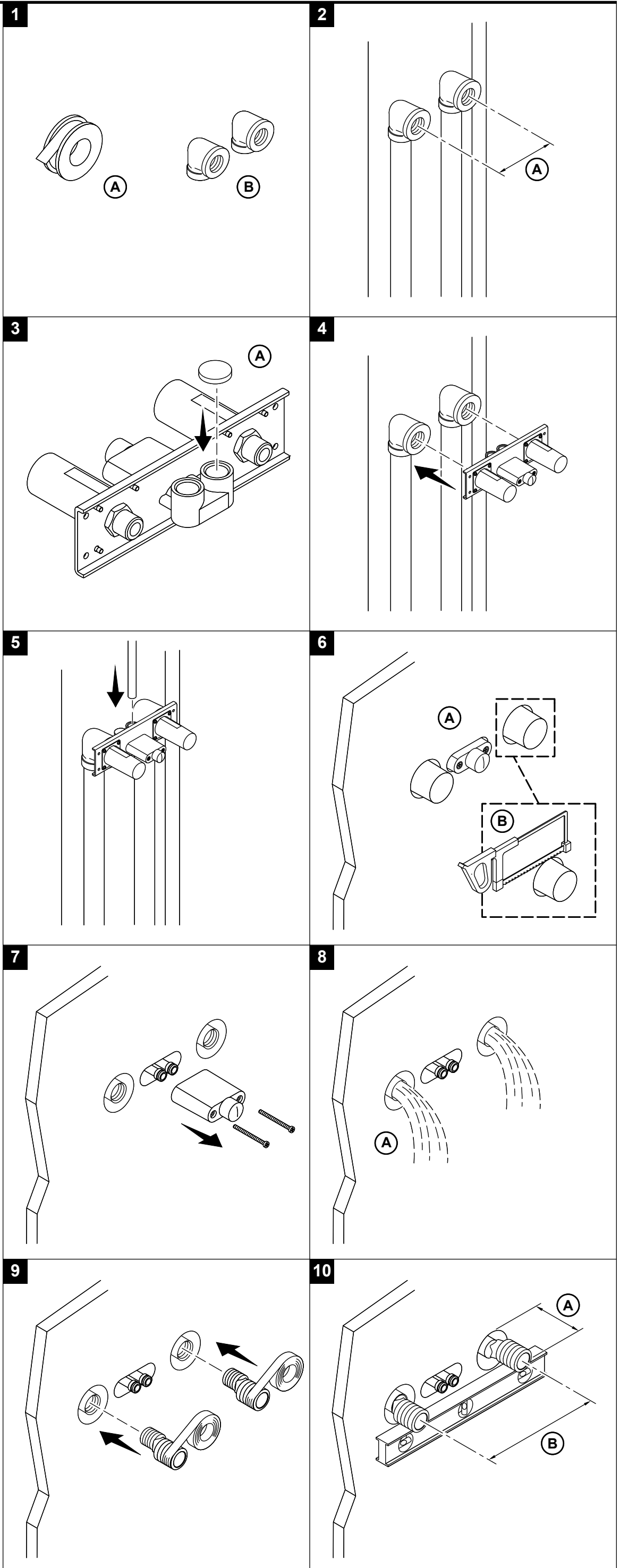

- จีนแผ่นดินใหญ่: +(86) 800-820-2628, +(86) 400-820-2628
- ฮองกง (จีน) มาเก๊า (จีน) ไต้หวัน (จีน): +(852) 3125-7728
- บรูไน กวม อินโดนีเซีย ญี่ปุ่น มาเลเซีย มองโกเลีย ฟิลิปปินส์ สิงคโปร์ เกาหลีใต้ เวียดนาม: +(86) 21-2606-2572

ผลิตภัณฑ์นี้ได้รับความคุ้มครองภายใต้การรับประกันแบบจำกัดเป็นระยะเวลาห้าปีสำหรับห้องน้ำ  
 KOHLER®ซึ่งสามารถดูได้ในจุดให้บริการปฏิบัติตามกฎระเบียบ

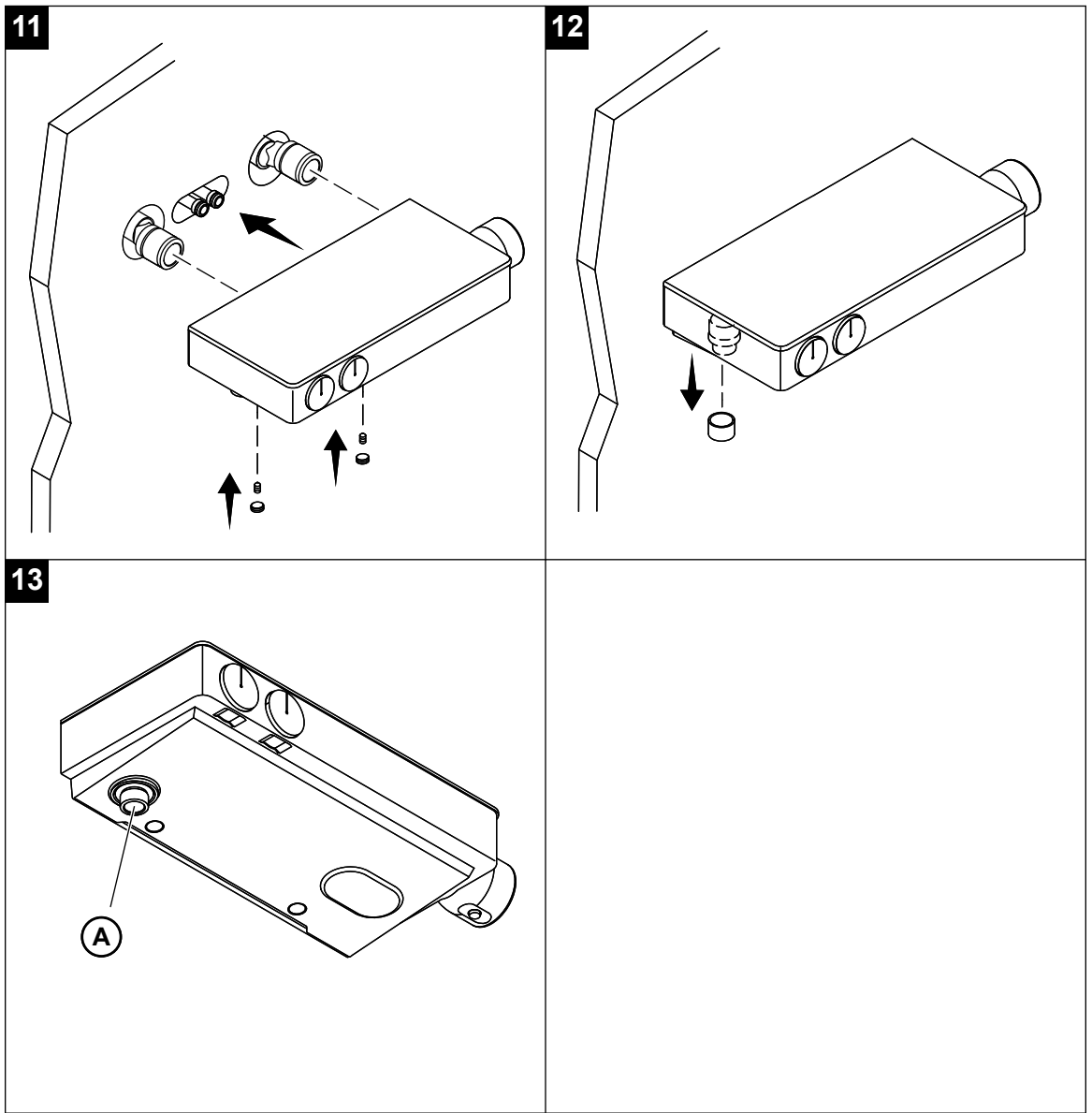



모델 번호 기록:

Ghi lại số model của bạn: \_\_\_\_\_

1466133-T2

**⚠ 경고: 화상 위험.** 높은 수온은 심각한 화상을 유발할 수 있습니다. 밸브 수온을 49°C(120°F) 이하로 설정하십시오. 밸브에 대한 온도 조정 지침을 참조하십시오.

모든 현지 배관 및 건물 규정을 따르십시오.

**1A.** 실란트 테이프

**1B.** G1/2 공급 엘보우

**2A.** 2개의 공급 엘보우를 5-7/8"(150mm) 간격으로 설치합니다.

**3A.** 브래킷 후면에 있는 포트 중 하나에 캡을 씌웁니다.

**6A.** 마감된 벽을 설치하십시오.

**6B.** 플라스틱 가드를 잘라내어 마감된 벽과 수평이 되도록 합니다.

**8A.** 급수 장치를 켜서 이물질을 내립니다.

**10A.** 오프셋 커넥터가 완성된 벽에서 1-5/16"(33mm) ~ 1-3/4"(44mm) 돌출되어 있는지 확인합니다. 필요한 경우 Z 커넥터를 변경하거나 조정합니다.

**10B.** 오프셋 커넥터가 중앙에서 중앙까지 수평으로 5-7/8"(149mm) ~ 5-15/16"(151mm)인지 확인합니다. 필요한 경우 조정합니다.

**13A.** 제조업체 지침에 따라 핸드샤워와 샤워헤드를 설치합니다.

**도움이 필요하십니까?** 고객 지원 센터에 문의하십시오.

• 태국: [callcenterthailand@kohler.com](mailto:callcenterthailand@kohler.com), +(66) 2700-9299

• 호주: 1800 KOHLER(1800-564-537)

• 뉴질랜드: 0800-564-537

• 중국 본토: +(86) 800-820-2628, +(86) 400-820-2628

• 홍콩(중국), 마카오(중국), 대만(중국): +(852) 3125-7728

• 브루나이, 괌, 인도네시아, 일본, 말레이시아, 몽골, 필리핀, 싱가포르, 대한민국, 베트남: +(86) 21-2606-2572

이 제품은 포장된 규정준수 인증서에 들어 있는 **KOHLER® 수도꼭지 5년 제한 보증**의 적용을 받습니다.

**⚠ CẢNH BÁO: Nguy cơ bị bỏng nước.** Nhiệt độ nước cao có thể gây bỏng nặng. Đặt nhiệt độ nước của van bằng hoặc dưới 120°F (49°C). Tham khảo hướng dẫn điều chỉnh nhiệt độ cho van.

Tuân thủ tất cả quy tắc về hệ thống ống nước và tòa nhà tại địa phương.

**1A.** Băng keo

**1B.** Ống khuỷu cấp G1/2

**2A.** Lắp hai khuỷu cấp cách nhau 5-7/8" (150 mm).

**3A.** Đậy nắp một trong các cổng ở mặt sau của giá đỡ.

**6A.** Lắp đặt tường hoàn thiện.

**6B.** Cắt các tấm bảo vệ bằng nhựa sao cho chúng ngang bằng với thành hoàn thiện.

**8A.** BẬT nguồn cấp nước để xả rác.

**10A.** Xác nhận rằng các đầu nối bù nhô ra từ 1-5/16" (33 mm) - 1-3/4" (44 mm) từ tường. Thay đổi hoặc điều chỉnh đầu nối z nếu cần.

**10B.** Xác minh rằng các đầu nối định tâm là 5-7/8" (149 mm) - 5-15/16" (151 mm) từ tâm đến ngang. Điều chỉnh nếu cần thiết.

**13A.** Lắp đặt tay vịn và vòi hoa sen theo hướng dẫn của nhà sản xuất.

**Quý vị cần trợ giúp?** Vui lòng liên hệ với Trung tâm Chăm sóc Khách hàng của chúng tôi.

• Thái Lan: [callcenterthailand@kohler.com](mailto:callcenterthailand@kohler.com), +(66) 2700-9299

• Úc: 1800 KOHLER (1800-564-537)

• New Zealand: 0800-564-537

• Trung Quốc đại lục: +(86) 800-820-2628, +(86) 400-820-2628

• Hồng Kông (Trung Quốc), Ma Cao (Trung Quốc), Đài Loan (Trung Quốc): +(852) 3125-7728

• Brunei, Guam, Indonesia, Nhật Bản, Malaysia, Mông Cổ, Philippines, Singapore, Hàn Quốc, Việt Nam: +(86) 21-2606-2572

Sản phẩm này được bảo hành theo **Bảo hành Giới hạn Năm Năm Dành cho Vòi nước KOHLER®**, có trong Chứng nhận Tuân thủ kèm theo.

